

# Mira EV Thermostatic Bar Valve Installation and User Guide

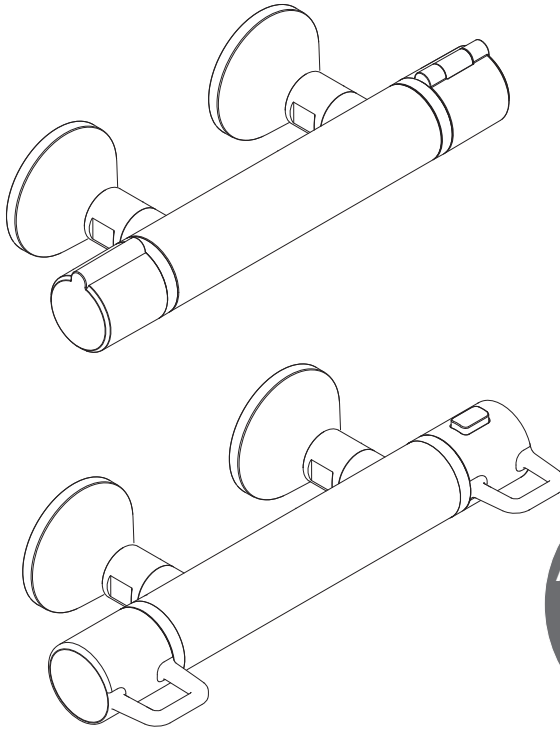

For SPARES,  
ADVICE or REPAIRS  
please call us free  
on 0800 001 4040  
(UK only)

## These instructions must be left with the user

Model Name:  
Product Code:  
Date of Manufacture:

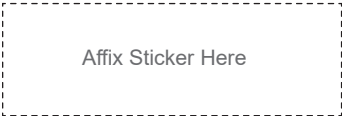

Affix Sticker Here

(Your guarantee information is included in this guide. Please keep these details safe as you will need them when registering your product guarantee.)



# Introduction

Thank you for choosing a Mira shower. To enjoy the full potential of your new shower, please take time to read this guide thoroughly, and keep it handy for future reference. Products manufactured by Kohler Mira Ltd are designed to be safe, provided that they are installed, used and maintained in good working order, in accordance with our instructions and recommendations.

Follow all warnings, cautions and instructions contained in this guide, and on, or inside the shower. This guide is also available in digital format from our website or by contacting customer services.

## Type 2 Valves

This product has been certified as a Type 2 valve. It also complies with the Water Supply (water fittings) regulations 1999. For further information on Type 2 Valves, refer to the TMV2 Requirements Manual (available to view or download on our website [www.mirashowers.co.uk](http://www.mirashowers.co.uk)). The approved designation for this product is listed in the table below.

Mira Mixer Showers covered by this guide:

Product Code	Model Number	Colour	Type 2 Designation
H06A	Mira Atom, Mira Coda Pro, Mira Reflex, Mira Apt, Mira Relate, Mira React	Chrome	HP-S
H06G	Mira Assist	Chrome	HP-S

# Guarantee

For **domestic installations**, Mira Showers guarantee the product against any defect in materials or workmanship for a period of **five** years from the date of purchase (shower fittings for one year).

For **non-domestic installations**, Mira Showers guarantee the product against any defect in materials or workmanship for a period of **one** year from the date of purchase.

**Failure to follow the instructions provided with the shower will invalidate the guarantee.**

For Terms and Conditions refer to the '**Activating Your Free Guarantee and Customer Service**' pages.

# Pack Contents

**Note! Only 1 pair of handles and 1 pair of concealing plates are provided and differ depending on product purchased.**

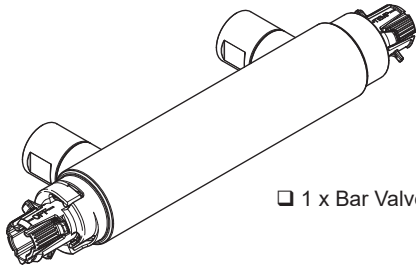

☐ 1 x Bar Valve

Assist and React Only



☐ 1 x 6 l/min Flow Regulator

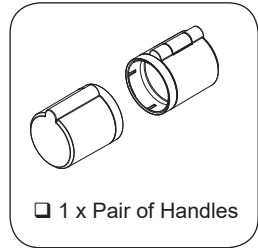

☐ 1 x Pair of Handles

OR

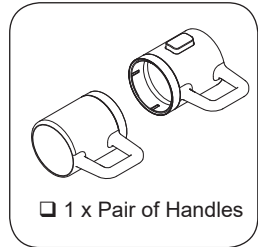

☐ 1 x Pair of Handles

OR

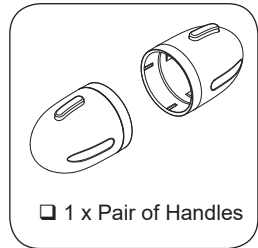

☐ 1 x Pair of Handles

OR

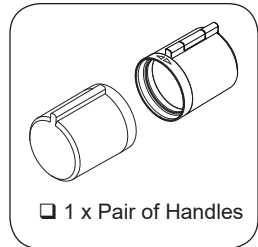

☐ 1 x Pair of Handles

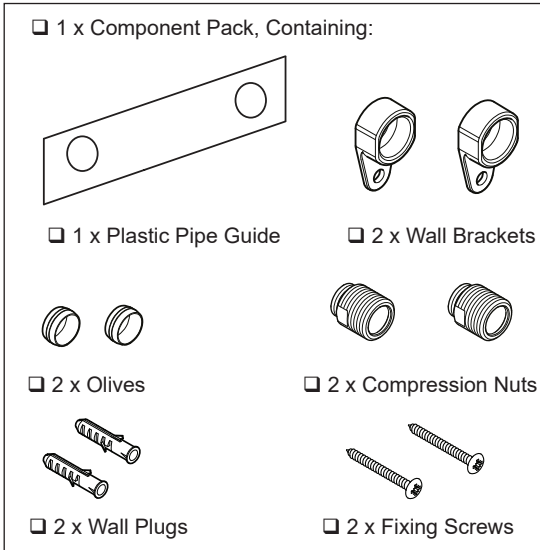

☐ 1 x Component Pack, Containing:

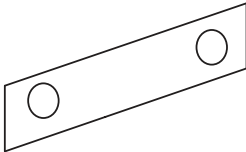

☐ 1 x Plastic Pipe Guide

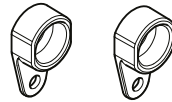

☐ 2 x Wall Brackets



☐ 2 x Olives



☐ 2 x Compression Nuts



☐ 2 x Wall Plugs



☐ 2 x Fixing Screws



☐ 2 x Concealing Plates

OR

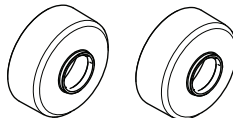

☐ 2 x Concealing Plates

## Documentation

1 x Installation and User Guide

Guarantee Card (Back pages of Installation and User Guide)

# Design Registration and Patents

Design Registration: GB 001225254-0003

Patents: GB 2 407 138

## Recommended Usage

Domestic	✓
Light Commercial	✓
Heavy Commercial	✗
Healthcare	✗

## Safety Information

**WARNING!** This shower can deliver scalding temperatures. For continued safe operation, follow all instructions, warnings and cautions contained in this guide and on or inside the shower. Periodic maintenance may be required to keep the product in good working order.

The function of a thermostatic mixing valve is to deliver water consistently at a safe temperature. In keeping with every other mechanism, it cannot be considered as functionally infallible and as such, cannot totally replace a supervisor's vigilance where that is necessary. Provided it is installed, commissioned, operated and maintained within manufacturers recommendations, the risk of failure, if not eliminated, is reduced to the minimum achievable.

**PLEASE OBSERVE THE FOLLOWING TO REDUCE THE RISK OF INJURY:**

### Installing the Shower

1. Installation of the shower must be carried out in accordance with these instructions by qualified, competent personnel. Read all instructions before installing the shower.
2. **DO NOT** install the shower where it may be exposed to freezing conditions. Ensure that any pipework that could become frozen is properly insulated.
3. **DO NOT** perform any unspecified modifications to the shower or its accessories. When servicing only use genuine Kohler Mira replacement parts.
4. If the shower is dismantled during installation or servicing then, upon completion, an inspection must be made to ensure all connections are tight and that there are no leaks.

## Using the Shower

5. The shower must be operated and maintained in accordance with the requirements of this guide. Make sure you fully understand how to operate the shower before use, read all instructions and retain this guide for future reference.
6. **DO NOT** switch the shower on if there is a possibility that the water in the shower unit or fittings is frozen.
7. The shower can be used by children aged from 8 years and above and persons with reduced physical, sensory or mental capabilities or lack of experience and knowledge if they have been given supervision or instruction concerning use of the appliance in a safe way and understand the hazards involved. Children must not be allowed to play with the shower.
8. Anyone who may have difficulty understanding or operating the controls of any shower should be attended whilst showering. Particular consideration should be given to the young, the elderly, the infirm or anyone inexperienced in the correct operation of the controls.
9. **DO NOT** allow children to clean or perform any user maintenance to the shower unit without supervision.
10. Always check the water temperature is safe before entering the shower.
11. **DO NOT** adjust the temperature control rapidly while using the shower.
12. Use caution when altering the water temperature while in use, always check the temperature before continuing to shower.
13. **DO NOT** switch the shower off and back on while standing in the water flow.
14. **DO NOT** fit any form of outlet flow control. Only Mira recommended outlet fittings should be used.
15. The showerhead must be descaled regularly. Any blockage of the showerhead or hose may affect showering performance.
16. The water supplies to this product must be isolated if the product is not to be used for a long period of time. If the product or pipework is at risk of freezing during this period they should also be drained of water.
17. When this product has reached the end of its serviceable life, it should be disposed of in a safe manner, in accordance with current local authority recycling, or waste disposal policy.

# Specifications

Pressures	
Maximum Static Pressure	1000 kPa (10 bar)
Maximum Maintained Pressure	500 kPa (5 bar)
Minimum Maintained Pressure (Gas Water Heater)	100 kPa (1 bar) (for optimum performance supplies should be nominally equal)
Minimum Maintained Pressure (Gravity System)	10 kPa (0.1 bar) (0.1 bar = 1 Metre head from cold tank base to shower handset outlet)
Plumbing Connections	
Hot: Left	15mm pipework, 3/4" BSP to valve
Cold: Right	15mm pipework, 3/4" BSP to valve
Outlet: Bottom	1/2" BSP Male to flexible hose
Temperatures	
Close temperature control	20°C - 50°C
Optimum Thermostatic Control Range	35°C to 45°C (achieved with supplies of 15°C cold, 65°C hot and nominally equal pressures)
Recommended Hot Supply	60°C to 65°C
Minimum Hot Water Supply Temperature	55°C <b>(Note:</b> The mixing valve can operate at temperatures up to 85°C for short periods without damage. However for safety reasons it is recommended that the maximum hot water temperature is limited to 65°C)
Minimum Recommended Differential between Hot Supply and Outlet Temperature	12°C at desired flow rates
Cold Water Range	1 - 25°C

## Thermostatic Shut-down

- For safety and comfort the thermostat will shut off the mixing valve **within 2 Seconds** if either supply fails (achieved only if the blend temperature has a minimum differential of 12°C from either supply temperature).

# Suitable Plumbing Installations

The Thermostatic Mixer can be installed with all systems with balanced pressures. Mixed gravity and mains supplies are not recommended.

## Installation

**Warning! This product does not allow for reversed inlets and will deliver unstable temperatures if fitted incorrectly.**

### General

1. Installation of the shower must be carried out in accordance with these instructions by qualified, competent personnel.
2. The plumbing installation must comply with all national or local water regulations and all relevant building regulations, or any particular regulation or practice specified by the local water supply company.
3. Make sure all pressures and temperatures comply with the requirements of the shower. See '**Specifications**'. For Type 2 Valves, refer to supply conditions given in the **TMV2 Requirements Manual (this is available to view or download from our website [www.mirashowers.co.uk](http://www.mirashowers.co.uk))**.
4. Full bore/non restrictive servicing valves must be fitted in a readily accessible position adjacent to the shower to facilitate maintenance of the shower.  
**DO NOT** use a valve with a loose washer plate (jumper) as this can lead to a build up of static pressure.
5. **DO NOT** apply excessive force to plumbing connections; always provide mechanical support when making plumbing connections. Any soldered joints should be made before connecting the shower.
6. Pipework dead-legs should be kept to a minimum.
7. **DO NOT** install the shower unit in a position where access for maintenance is restricted.
8. The shower must be fitted to a waterproof, flat and even wall surface. The two screws and wall plugs supplied are suitable for most solid wall installations. Alternative fixing screws for panel structures are not supplied. Use both fixing points to secure the shower, be sure to use fixings appropriate for the chosen wall structure.
9. When pipework enters the product from the rear through a hole in the wall, provision must be made to prevent water ingress back into the wall structure.
10. Position the shower unit where the controls are at a convenient height for the user. Position the showerhead so that the water sprays in line with the bath or across the opening of a shower cubicle. The installation must not cause the shower hose to be kinked during normal use.

11. The water supplies to this product should be isolated if the product is not to be used for a long period of time. If the product or pipework is at risk of freezing during this period they should also be drained of water.
12. The position of the shower and shower fittings must provide a minimum air gap of 25 mm between the showerhead and the spill over level of any bath, shower tray or basin. There must be a minimum distance of 30 mm between the showerhead and the spill over level of any toilet, bidet or other appliance with a Fluid Category 5 backflow risk.

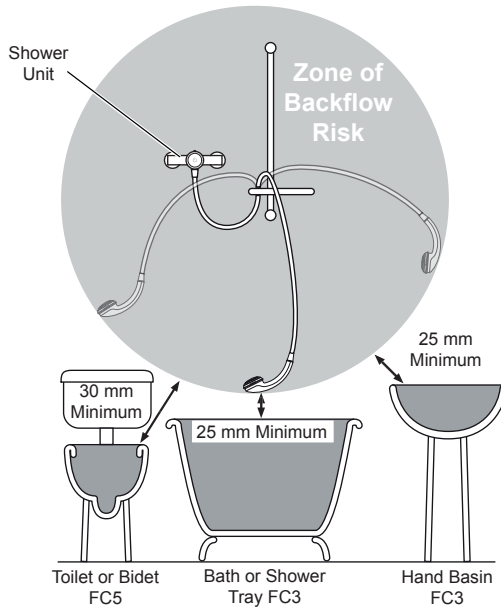

**Note:** There will be occasions when the hose retaining ring will not provide a suitable solution for Fluid Category 3 installations. In these instances an outlet double checkvalve must be fitted, this will increase the required supply pressure typically by 10kPa (0.1 bar). Double checkvalves fitted in the inlet supply to the appliance cause a pressure build up, which affects the maximum static inlet pressure for the appliance and must not be fitted. For Fluid Category 5, double checkvalves are not suitable.

## Installation of the Bar Valve

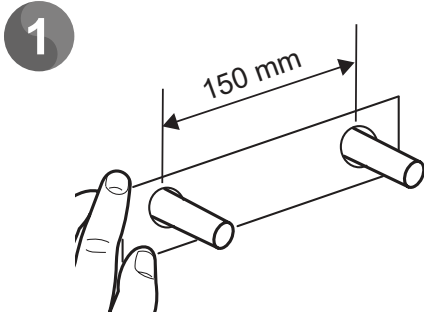

Fit the plastic pipe guide over the inlet pipes. Level the pipe guide and secure to the wall to hold in position. **Leave the guide in place and finish the wall.**

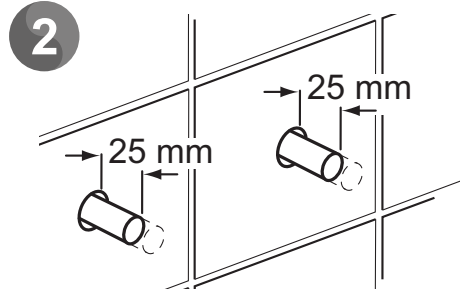

**Note: Connections are; Hot-Left, Cold- Right.**

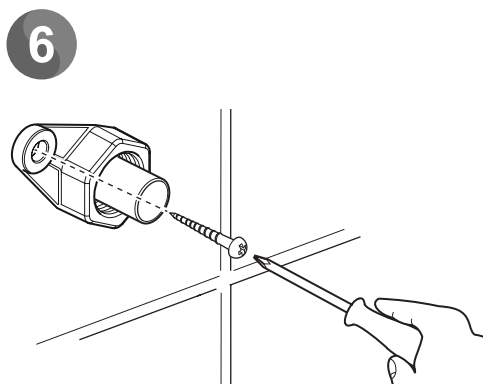
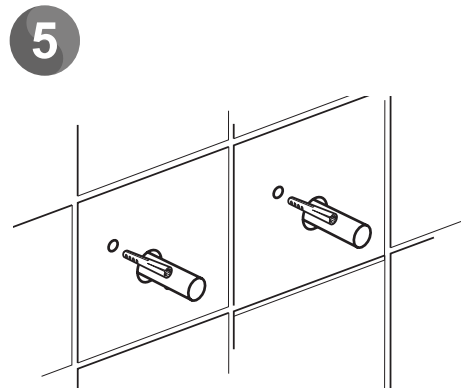
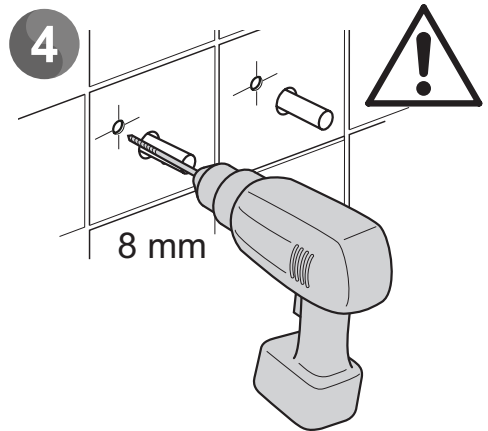
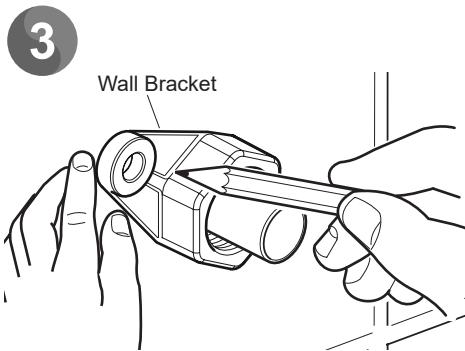

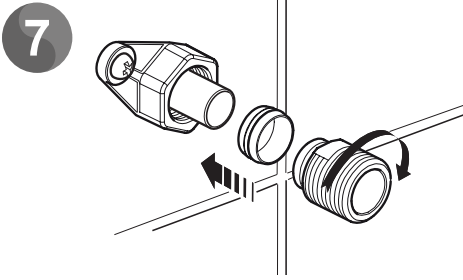

Install the olives and the connectors. Tighten finger tight and then another 1/4 to 1/2 turn.

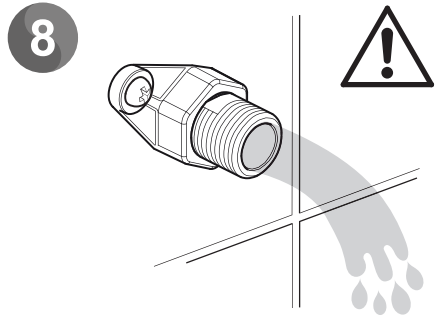

Turn on the water supply and flush the pipework.

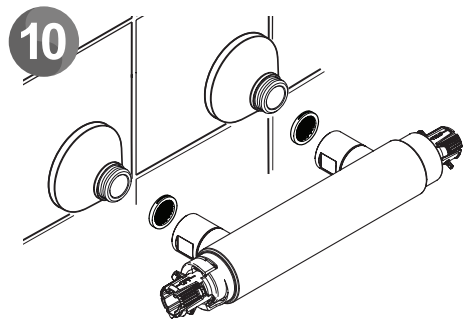
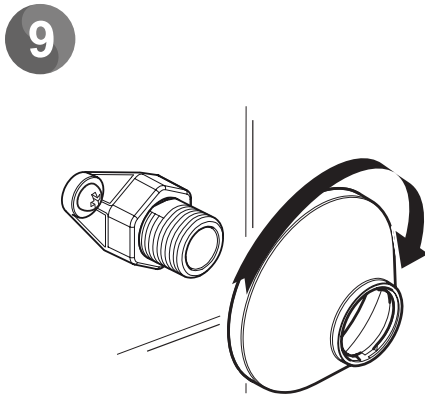

Attach the bar valve to the wall fixings.

**Note: Make sure that the sealing washer/filter is installed in each inlet.**

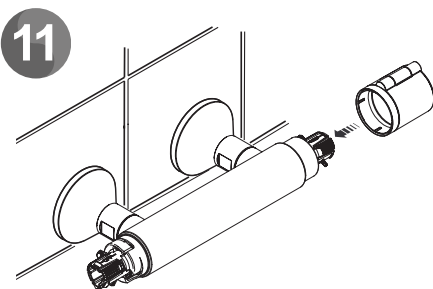

Install the temperature handle.

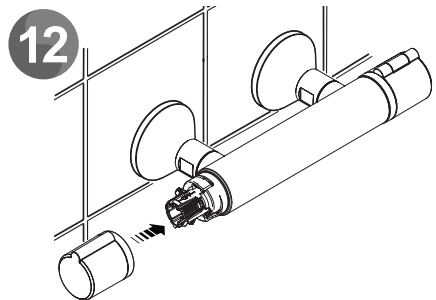

Install the flow handle.

**Note: Fit the handles. See Instructions on the box in which the handles are packed.**

13

Install the shower fittings, refer to the Installation Guide packed with the product.

14

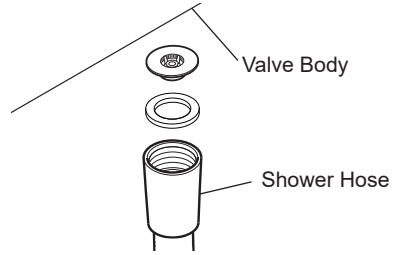

On some models (Assist and React) a 6 l/min flow regulator can be fitted into the outlet.

**Note: Orientate flow regulator as shown above.**

## Commissioning

### Maximum Temperature Setting

Before using the shower, the maximum temperature must be checked to make sure that it is at a safe level. It has been preset to a safe showering temperature under ideal conditions at the factory, appropriate for most systems. However, site conditions and personal preference may make it necessary to reset this temperature.

**Note: Make sure that the hot water temperature is at least 55°C and that there is sufficient supply.**

**Caution! Before testing the mixer, make sure that the hot and cold water is flowing correctly by exercising the temperature handle from hot to cold.**

1. Turn the temperature handle **anticlockwise** until it stops and test that the temperature of the water from the shower outlet is hot enough.
2. If not, depress the override button and **carefully** rotate the handle further. If the water temperature is still not hot enough complete the following procedure.
3. Rotate the temperature selector handle back to the override position.
4. Remove temperature handle by pressing the override button and pulling the handle.

**Note: The end cap on the Assist handles must be removed before pulling off.**

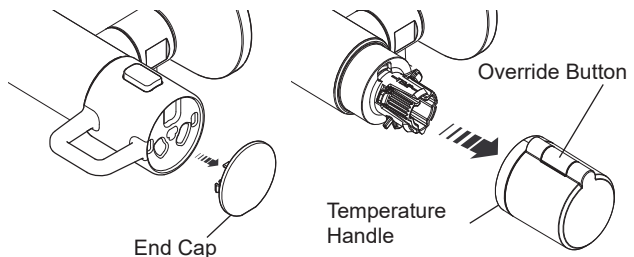

5. Remove the fixing screw holding on the handle attachment components using a 2.5 mm Allen key. Remove the two attachment components.

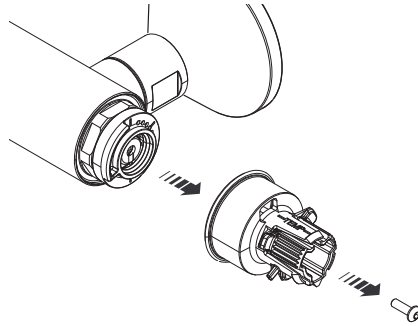

6. Temperature adjuster can be moved 3 positions in either direction, one position equals 1°C. Rotate adjuster anti-clockwise to increase temperature and rotate clockwise to decrease temperature.

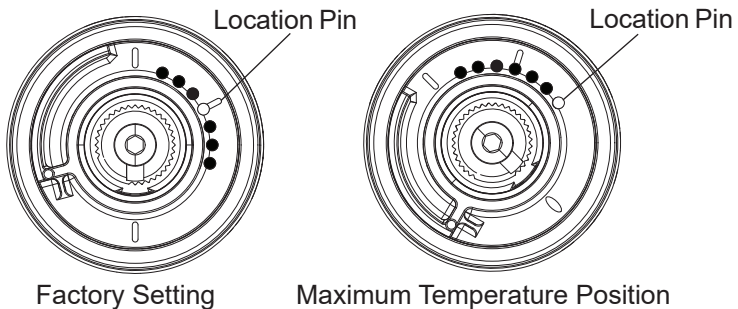

7. Replace the attachment components and make sure the fixing screw is fully tightened. Refit the handle.

## Cleaning

### Cleaning

Many household and commercial cleaners, including hand and surface cleaning wipes contain abrasives and chemical substances that can damage plastics, plating and printing and should not be used. These finishes should be cleaned with a mild washing up detergent or soap solution, and then wiped dry using a soft cloth.

**Important! The showerhead must be de scaled regularly,** keeping the showerhead clean and free from lime scale will ensure that your shower and showerhead continue to perform to their maximum. A blocked showerhead can restrict the flow rate and may cause damage to your shower.

# Operation

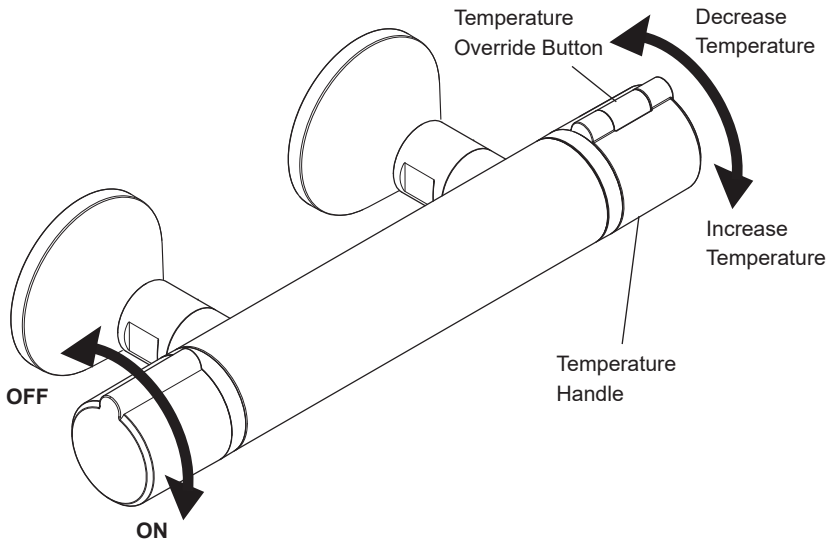

## Adjusting the Temperature

The temperature is controlled by rotating the temperature handle. For safety reasons, the temperature is limited by an override stop. To obtain a higher temperature, press the override button on the temperature handle and continue to rotate the handle.

## Adjusting the Flow

The flow is controlled by rotating the flow handle.

# Fault Diagnosis

If you require a Mira trained service engineer or agent, refer to **'Customer Service'**.

Symptom	Cause/Rectification
Water too hot or too cold	Inlets reversed (hot supply to cold supply). Rework inlet pipework. Check filters for any blockage. Check the maximum temperature setting (If you have a combination type boiler it may not be producing sufficient hot water at the desired flow rate). Fit a flow regulator to the shower valve outlet. Installation conditions outside operating parameters. Refer to <b>Specifications</b> and <b>Commissioning</b> .
Poor temperature control	Make sure that the inlet temperature differentials are sufficient, refer to <b>'Specifications'</b> . If fitted to a combi boiler ensure there is sufficient pressure and flow to deliver a constant hot water inlet supply. Check the shower handset, hose and inlet filters for any blockage and clean where necessary.
Fluctuating or reduced flow	Check the shower handset, hose and filters for any blockage. Make sure that the maintained inlet pressures are nominally balanced and sufficient. Refer to Specifications. Air lock or partial blockage in the pipework.
Water leaking from the shower handset/overhead	Normal for a short period after shut off. Check that the pressures are not in excess of the specifications for this product. There may be occasions where the overhead shower or shower handset empties for a while after the shower has been used, this is due to changes in ambient temperatures and is normal. It is recommended that all outlets are therefore enclosed within the water catchment area.

## What to do if something goes wrong

If your product does not work correctly check that it is installed and commissioned in accordance with our instructions. If this does not resolve the issue, contact us for help and advice. Refer to Customer Service page for more details.

## Spare Parts

A list of spares for these products are available from the Mira Website, visit website [www.mirashowers.co.uk](http://www.mirashowers.co.uk).

# Activate your Free\* Guarantee

Thankyou for choosing Mira. By registering your product, this will act as your proof of purchase and enable us to provide the best possible after sales service.

**REGISTER NOW** visit the Mira website guarantee page

[www.mirashowers.co.uk/support/guarantee.htm](http://www.mirashowers.co.uk/support/guarantee.htm)

(You will need the Model Name, Product Code and Date of Manufacture. This information can be found on the front page of this guide)

\* If you do not activate your guarantee proof of purchase will be required.

Mira has appointed Domestic & General Insurance PLC to provide product registration services and protection plans to accompany its products.

## What we do with your information

At Domestic & General we want to reassure you that we use your information both responsibly and securely to provide you with the best possible service. Below we explain what we do with your information and your rights to your information. If you would like any further details you can get in touch with us using the contact details below or visit our website ([www.domesticandgeneral.com](http://www.domesticandgeneral.com)).

## Using your information

Domestic & General Insurance PLC ("we") is the "data controller" of your information. We process two sets of information about you, "Personal Information" (your name, address, contact and payment details) and the "Goods Information" you provide to register your appliance or device (your name, address, contact and goods details). We'll use your information:

(i) As necessary to fulfil our contract with you (including to recover any amounts owing); (ii) for our legitimate interests in: undertaking marketing (about our products and services and those of our third party partners) by post, telephone, email and/or other electronic messaging services; market research; customer surveys; printing services; checking and verifying your identity and contact details; recording your conversations for training, quality and compliance purposes; and for analytics and profiling for marketing purposes; and (iii) where required to do so by law. We may also ask for your consent to some uses of your information.

## Sharing your information

From time to time your Personal Information and Goods Information may also be shared with other members of the Domestic & General Group of Companies (Domestic & General Insurance or Services and other future members of the Group whose details we will notify to you ("Group")), where applicable with Kohler Mira Limited which is the subject of your protection policy and with companies acting on our behalf or providing services to us (e.g. the companies we use to carry out repairs, IT & mailing services, storage of paper records and telecommunications). Kohler Mira Limited will process your Personal Information for their legitimate business interests (including marketing and analytics) in accordance with their privacy policy.

## Transferring your information

In exceptional cases, we may transfer your information to countries outside the European Economic Area (including the US) which may not have data protection laws which provide the same level of protection as provided in the UK. We have put in place Model Clauses as an appropriate safeguard to ensure that such information is adequately secured and protected and that such transfers meet the requirements of applicable data protection law.

## Keeping your information

We keep your Personal Information for six years after you terminate your policy so that we can deal with any claims. Your goods information we keep for a bit longer, normally 10 years (the average life of an appliance) for health and safety. We also keep your information to send you marketing that you might be interested in, unless we receive a request from you to opt-out of marketing.

## Rights to your information

By writing to the Data Protection Officer using the contact details provided below, you have the right to ask us:

- For a copy of the Personal Information we hold about you
- For a copy of the Personal Information you provided to us to be sent to you or a third party in a commonly used, machine readable format
- To update or correct your Personal Information to keep it accurate
- To delete your Personal Information from our records if it is no longer needed for the original purpose; and
- To restrict the processing of your Personal Information in certain circumstances

And you may also:

- Object to us processing your Personal Information, in which case we will either agree to stop processing or explain why we're unable to, and
- Where we rely on your consent, withdraw that consent at any time

Please note that the above rights are not absolute and certain exemptions apply to them. You can also make a complaint to the Information Commissioner ([www.ico.org.uk](http://www.ico.org.uk)) if you feel your Personal Information has been mishandled.

## Marketing

We, along with other members of our Group and Kohler Mira Limited may use your information to tell you about any offers, products or services which may be of interest to you. We may contact you by post, telephone, email and/or other electronic messaging services.

To change your marketing preference, let us know by emailing [marketingpreferences@domesticandgeneral.com](mailto:marketingpreferences@domesticandgeneral.com) or by writing to us using the contact details provided below. For Kohler Mira Limited marketing you'll need to contact them directly using their contact details that you'll normally find in their privacy notice.

## Contact Details

If you need to contact us about your information or your information rights, or to see a copy of our Model Clauses, please write to Freepost Plus RTKS-CLRA-GRYE, Data Protection Officer, Domestic & General, Leicester House, 17 Leicester Street, Bedworth CV12 8JP or [dataprotection@domesticandgeneral.com](mailto:dataprotection@domesticandgeneral.com) and we'll be happy to help you.

# Customer Service

## Guarantee

Your product has the benefit of our manufacturers guarantee which starts from date of purchase. This guarantee only applies in the United Kingdom and Republic of Ireland.

Within the guarantee period we will resolve defects in materials or workmanship, free of charge, by repairing or replacing parts or product as we may choose.

## Activating Your Guarantee

Registering your guarantee is quick and simple. To ensure your product is covered, please register online <https://www.mirashowers.co.uk/support/guarantee-registration>.

**This guarantee is in addition to your statutory rights and is subject to the following conditions :**

- The guarantee applies solely to the original installation under normal use and to the original purchaser only. The product must be installed and maintained in accordance with the instructions given in this guide.
- Servicing must only be undertaken by us or our appointed representative.  
**Note!** If a service visit is required the product must be fully installed and connected to services.
- Repair under this guarantee does not extend the original expiry date. The guarantee on any replacement parts or product ends at the original expiry date.
- For shower fittings or consumable items we reserve the right to supply replacement parts only.

**The guarantee does not cover:**

- Call out charges for non product faults (such as damage or performance issues arising from incorrect installation, improper use, inappropriate cleaning, lack of maintenance, build up of limescale, frost damage, chemical attack, corrosion, system debris or blocked filters) or where no fault has been found with the product.
- Water or electrical supply, waste and isolation issues.
- Compensation for loss of use of the product or consequential or indirect loss of any kind.
- Damage or defects caused if the product is repaired or modified by persons not authorised by us or our appointed representative.
- Routine maintenance or replacement parts to comply with the requirements of the TMV2 or TMV3 healthcare schemes.
- Accidental or wilful damage.

- Products purchased ex-showroom display.

## What to do if something goes wrong

If your product does not work correctly refer to this manual for fault diagnosis and check that it is installed and commissioned in accordance with our instructions. If this does not resolve the issue, contact us for help and advice.

### Helpdesk Service

Contact our Customer Services Team for product advice, to purchase spare parts or accessories or to set up service visit. You can contact us via phone or e-mail - contact details below.

Please provide your model name, power rating (if applicable) and date of purchase.

### Mira Showers Website

[www.mirashowers.co.uk](http://www.mirashowers.co.uk)

Visit our website to register your guarantee, download user guides, diagnose faults, purchase our full range of accessories and popular spares, or request a service visit.

### Spares and Accessories

We hold the largest stocks of genuine Mira spares and accessories. Contact us for a price or visit our website to purchase items from our accessory range and popular spares. (Only available in the United Kingdom )

### Service/Repairs

No one knows our products better than our nationwide team of Service Technicians. We can carry out service or repair work to your product both during and after the guarantee period. (Only available in the United Kingdom and Republic of Ireland) Ask about our fixed price service repairs.

### To Contact Us: UK



**0800 001 4040**

**Fax: 01242 282595**



Email – Visit

[www.mirashowers.co.uk/contactus](http://www.mirashowers.co.uk/contactus)



By Post: **Mira Customer Services Dept, Cromwell Road, Cheltenham, Gloucestershire GL52 5EP**

### To Contact Us: Eire Only



**01 531 9337**



E-mail:

[CustomerServiceEire@mirashowers.com](mailto:CustomerServiceEire@mirashowers.com)

*Mira is a registered trade mark of Kohler Mira Limited.*

*The company reserves the right to alter product specifications without notice.*



**mira**  
SHOWERS