

## Polypropylene Toilet Seats

Please follow the fixing and care instructions to ensure that your toilet seat is fitted safely and that it retains its high quality finish. Please retain this leaflet for future reference.

This installation guide applies to the following products:

**WL401022H Canada Polypropylene Anti-Bac Toilet Seat**

**WL401122H Panama Polypropylene Anti-Bac Toilet Seat**

### Home Safety Advice

- Do not strike the product with hard or sharp objects.
- Do not stand on the lid or the seat.
- Avoid slamming the lid or seat.

### Product Care

- To retain the best quality finish, clean product with a soft cloth and a mild soap solution.
- Do not use abrasive or chemical cleaners as they may damage the surface of the toilet seat or hinges.
- Take care when cleaning the toilet pan with chemical cleaners. Avoid contact of the chemical cleaners with the toilet seat or hinges. Immediately rinse off any splashes to avoid damage or discolouration of the surface of the toilet seat and hinge parts.

### Useful Tip!

To prevent dropping small parts into the toilet whilst fitting the toilet seat, stretch a piece of cling film over the rim of the toilet to cover the bowl. Don't forget to remove afterwards though!

#### Fitting Pack Contents (Not to scale)

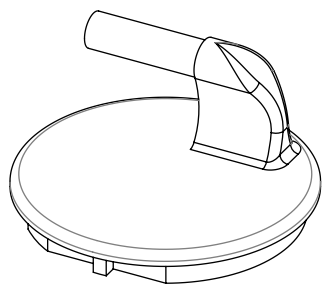

**A**  
Hinge Body - Left x 1

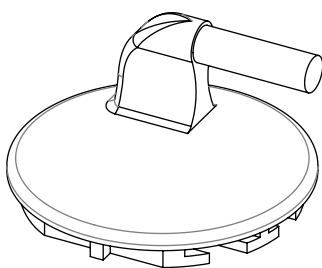

**B**  
Hinge Body - Right x 1

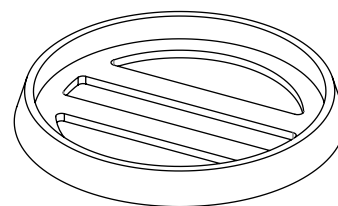

**C**  
Hinge Base Plate x 2

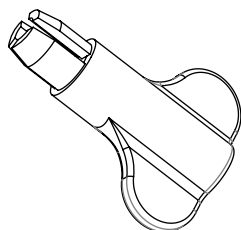

**E**  
Plastic Nut x 2

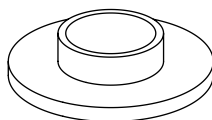

**F**  
Plastic Tapered Washer x 2

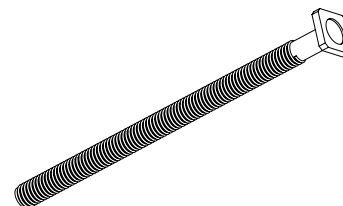

**G**  
Threaded Fixing Bolt x 2

## Assembly Instructions

1. Slide one threaded fixing bolt into the middle channel on the underside of each hinge body. Fig 1
2. Attach the hinge bodies to the toilet seat so that the base of the hinge body faces downwards. Fig 2. The hinge tops are left and right handed as shown in the fitting pack content illustrations, these are side reversible to allow further adjustment of the toilet seat on the toilet pan, either forwards or backwards as required.
3. Place a hinge base plate onto the toilet pan over each mounting hole so that the slots run horizontally left to right. Fig 3
4. Next place the toilet seat onto the toilet pan ensuring that the threaded fixing bolts pass through the corresponding middle slots on each hinge base plate and through the two mounting holes on the toilet pan. Fig 4.
5. Align the toilet seat with the toilet pan ensuring that the seat is far enough forward on the pan to allow the lid and seat to stay up when lifted to an upright position. If adjustment is required the other slots on the underside of the hinge body can be used to move the seat position either forwards or backwards.

N.B. Refer back to step 2 for additional adjustment if required.

6. When the seat is in the correct position on the toilet pan place a plastic tapered washer onto the end of each threaded fixing bolt followed by a plastic nut in the orientations shown in Fig 5 and fully tighten onto the toilet pan. Do not use pliers or other tools to tighten the plastic nuts as over tightening may occur which could permanently damage the plastic thread.

N.B. It is important that the plastic tapered washers and plastic nuts are assembled onto the threaded fixing bolts exactly as shown in Fig 5. or it will not be possible to tighten the nuts. The flat surface of the plastic tapered washer must face upwards so it locates onto the underside of the mounting hole on the WC pan. The three tapered fingers on the plastic nut must also face upwards as these locate into the tapered hole on the underside of the plastic tapered washer.

FIG 1

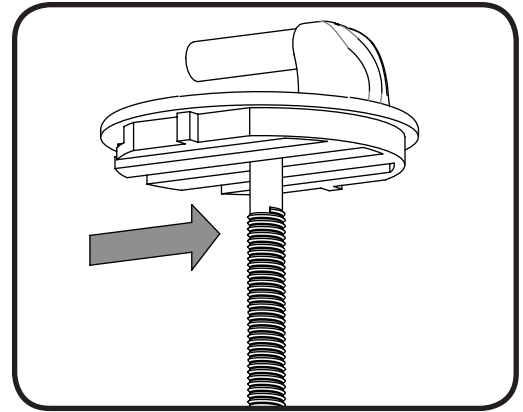

FIG 2

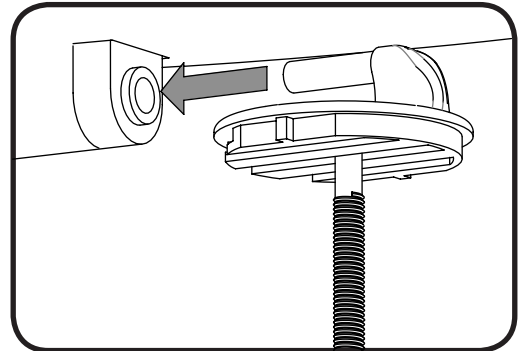

FIG 3

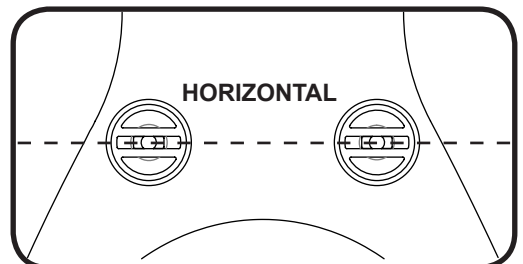

FIG 4

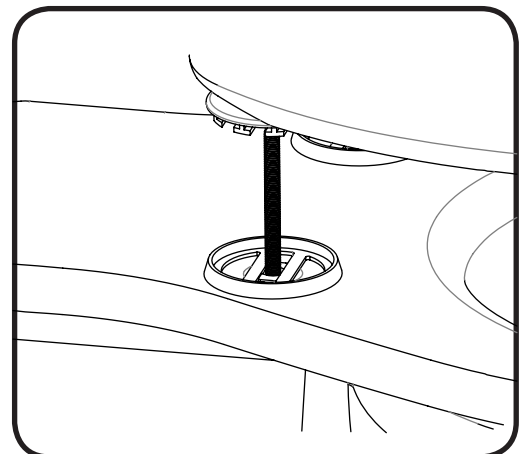
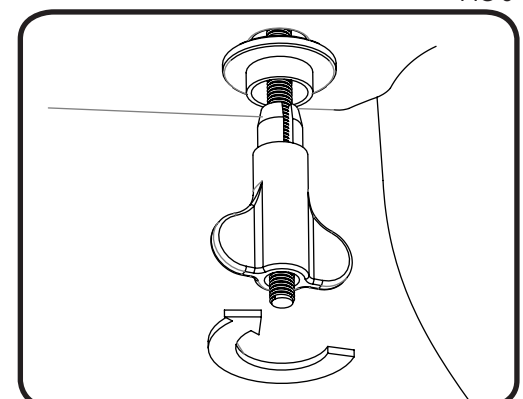

FIG 5



For details of the other items in the Croydex range please visit our website: [www.croydex.com](http://www.croydex.com)

Croydex Limited, Central Way, Andover, Hampshire, SP10 5AW, UK  
Tel: +44 (0) 1264 365881 Fax: +44 (0) 1264 356437  
E-mail: [info@croydex.co.uk](mailto:info@croydex.co.uk)