

INSTALLATION INSTRUCTION - STANDARD BATHS

Warning:

Please read these instructions carefully before installing the product.

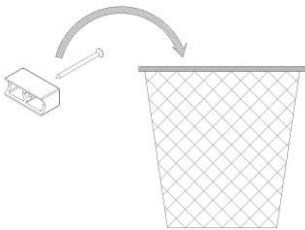

Discard 50mm transportation screws and plastic blocks for the tubular legs as these items are NOT REQUIRED.

After removing the packaging check the product carefully for impact damage or visual faults before commencing installation.

Notice to Installer:

Please ensure that these instructions are left with the product for the user to read.

Guarantee:

This product is guaranteed against defects in workmanship and materials. Please see the Guarantee Section of these instructions for the full terms of the guarantee.

(Applicable to UK and Republic of Ireland only)

1. Technical Information.

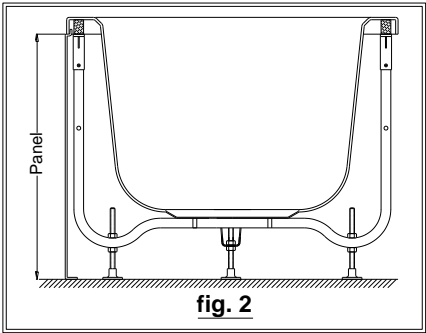
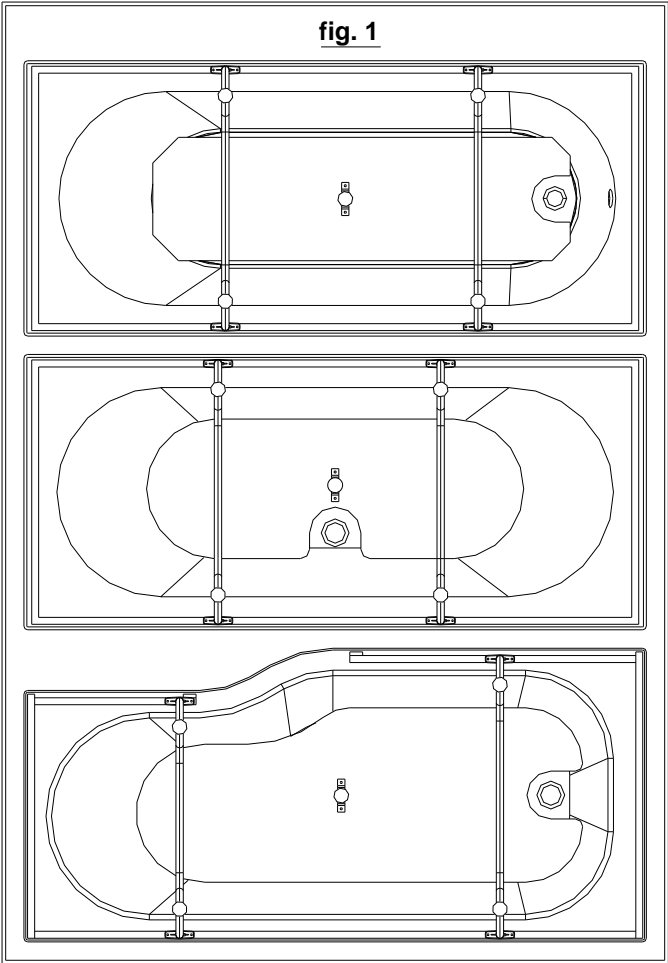

2. Installation Procedure.

1. Ensure working area is clear and free of debris that may damage product.
 2. Please remove protective film and inspect the product carefully for damages or defects before installation. Any damages found must be reported to the product supplier immediately.
 3. Lay bath face down and carefully remove support legs and all fitting packs. Detach cardboard wrap, leaving underneath bath as protective matting.
- Discard 50mm transportation screws and plastic blocks for the tubular legs as these items are NOT REQUIRED.**
4. Choose the style of bath that best matches your bath (ref fig. 1). Position the plastic sockets as shown & secure to frame (ref fig. 3(a)).
 5. Insert support legs into plastic socket and fix to baseboard (*which may be encapsulated*) using 4 No. 4 x 30mm countersunk pozi-head woodscrew.
 6. Pilot drill 4 off plastic socket through one side of support leg using Ø3mm drill bit (ref fig. 3(a)).
 7. Secure support legs to plastic socket using 4 No. 4 x 12mm long pozi-head self tapping screws (ref fig. 3(a)).
 8. Secure centre-support bracket using 2 No. 4 x 16mm long countersunk pozi-head woodscrews (ref fig. 3(b)).
 9. Fit 4 off M10 x 152mm long adjustable feet using M10 nuts provided (ref fig. 3(c)), then 1 off M10 x 120mm long adjustable foot for centre-support bracket to give required floor to rim height
 10. Fix 2 off wall brackets to support frame using 2 No. 4 x 16mm long countersunk pozi-head woodscrews as indicated (ref fig. 3(d)).
 11. Carefully turn bath over.
 12. With bath in final position, level bath rim using adjustable feet, making enough allowance for panel installation if required, (note: bath must be supported on all 5 adjustable feet). Ensure panel height is taken into consideration before final fit (ref. fig. 2 – dimension 'Panel').
 13. Fix wall brackets to wall (screws not supplied).
 14. Fix adjustable feet to floor (screws not supplied) and ensure M10 nuts are tightened.
 15. Leave instructions in bath for end user.

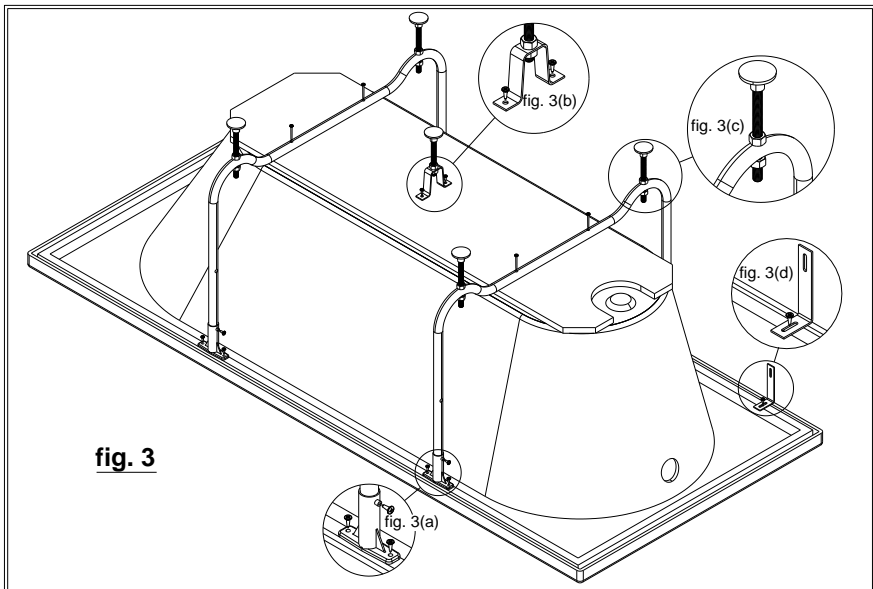

fig. 3

3. Bath Care Instructions.

Filling – Always run cold water into the bath first.

Cleaning – Clean immediately after use with warm, soapy water and wipe dry. Never use gritty or abrasive cleaners.

Remove slight scratches and lime scale build-up with metal polish and then clean as normal. Replace worn washers on dripping taps to prevent surface marking.

Warning – Solvents such as paint stripper or nail varnish remover will damage the bath. Burning cigarettes will damage the bath.

4. Guarantee.

We guarantee our products against defects in workmanship and materials. The period of the guarantee is five years from the date of purchase for baths and two years from the date of purchase for bath panels.

This guarantee is subject to the following conditions and exclusions:

1. This guarantee applies only to products purchased and installed in the United Kingdom or the Republic of Ireland.
2. You must retain your purchase receipt and produce it to us in the event of a claim. The guarantee commences from the date of purchase.
3. The product must have been installed, used and cared for in accordance with our Instructions for installation and care. In addition, the products must have been installed in accordance with good plumbing practice.
4. We must be given the opportunity to inspect the product where it has been installed, if we request to do so. The product should not be removed before inspection without our consent.
5. Where we are satisfied that a defect has arisen in manufacture because of faulty workmanship or materials we will, at our option, repair or replace the product free of charge to you. If we choose to replace the product and we no longer manufacture the identical model we will replace it with the nearest equivalent in our then current range.
6. This guarantee does not apply to general wear and tear or where, in our opinion, the product has been modified, misused, neglected or wilfully or accidentally damaged.
7. This guarantee does not extend to the costs of removing the defective product and installing the replacement product or to any other costs or losses.
8. If we supply a replacement product this guarantee shall apply to the replacement product for the balance of the original guarantee period for that product.
9. This guarantee applies only to products installed in domestic premises and is not transferable to a new owner of the product.

Nothing in this guarantee affects your statutory rights.

Due to continuous improvements in the design and performance of our products, we reserve the right to update, amend and vary specification without prior notice.

For Further information, please contact your point of sale.