

Technical Data Sheet

EMINENCE – EM55CAL, EM65OAL, EM70RAL, EM80CAL, EM80PAL & EM80RAL

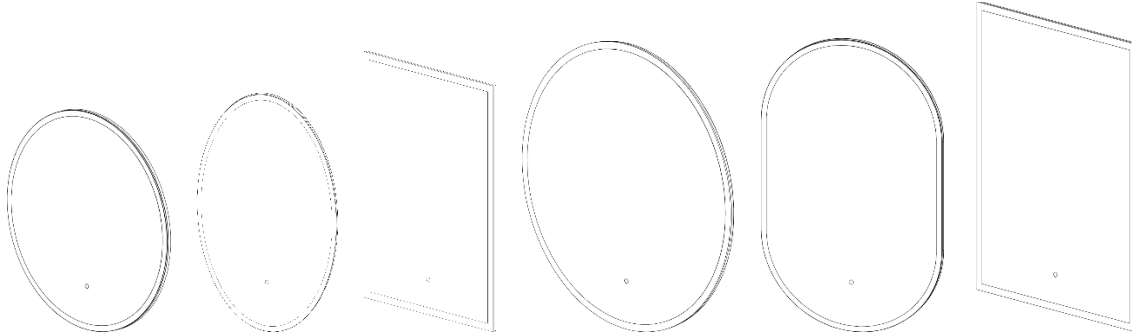

Box Contents:

Eminence Mirror | Remote | 2x wall plugs | 2x screws | Instructions booklet

Materials

Frame Material: Extruded Aluminium

Glass: 5mm PVC Backed

FAQ's:	Units	EM55CAL	EM65OAL	EM70RAL	EM80CAL	EM80PAL	EM80RAL
Can the mirror be hung landscape?	-	No	No	No	No	Yes	No
What is the thickness of the mirror glass?	mm	5					
Is the mirror IP44 rated?	-	Yes – Suitable for use in bathroom zone 2					
What size fuse should I use?	-	Seek the advice of an electrician					
What is the total power consumption?	W	29	34	48	59	52	61
Does the mirror have an energy rating?	-	Yes – It has an energy rating of: A					
What is the colour of the light and the Kelvin rating?	K	2700 - 6000					
What is the Lumen of the LEDs?*	Lms	1581	1632	2040	2448	2244	2652
What is the wattage of the lights?	W	15.5	16	22	24	20	26
Where is the IR sensor/rocker switch located?	-	Centre front middle					
Can the LED lighting be replaced?	-	No**					
Can the IR sensor be replaced?	-	Yes					
What is the output of the demister pad?	W	15	19.6	26	35	34	35
What are the dimensions of the demister pad? (L x W)	mm	200 x 300	270 x 290	230 x 450	310 x 450	340 x 400	310 x 450
How do I turn on the demister pad?	-	The demister pad will turn on when the LEDs are turned on.					
Are illuminated mirrors supplied with mains cable?	-	All illuminated mirrors are supplied with a removeable 500mm mains cable. There is ample storage for excess cable in the back of the unit.					

Dimensions are subject to change; customers are advised to measure actual product before commencing installation.

Fixing point dimensions are for guidance only/the positions of wall fixing must be checked when product is received.

*The Lumen represents the output of the LED. This may vary depending on the diffuser material i.e., glass or acrylic.

**The LEDs are not replaceable to maintain the integrity of the product's resistance to moisture ingress

