

Sales Code: ERQ7

Description: 700 X 700 X 1850mm Quadrant Enclosure

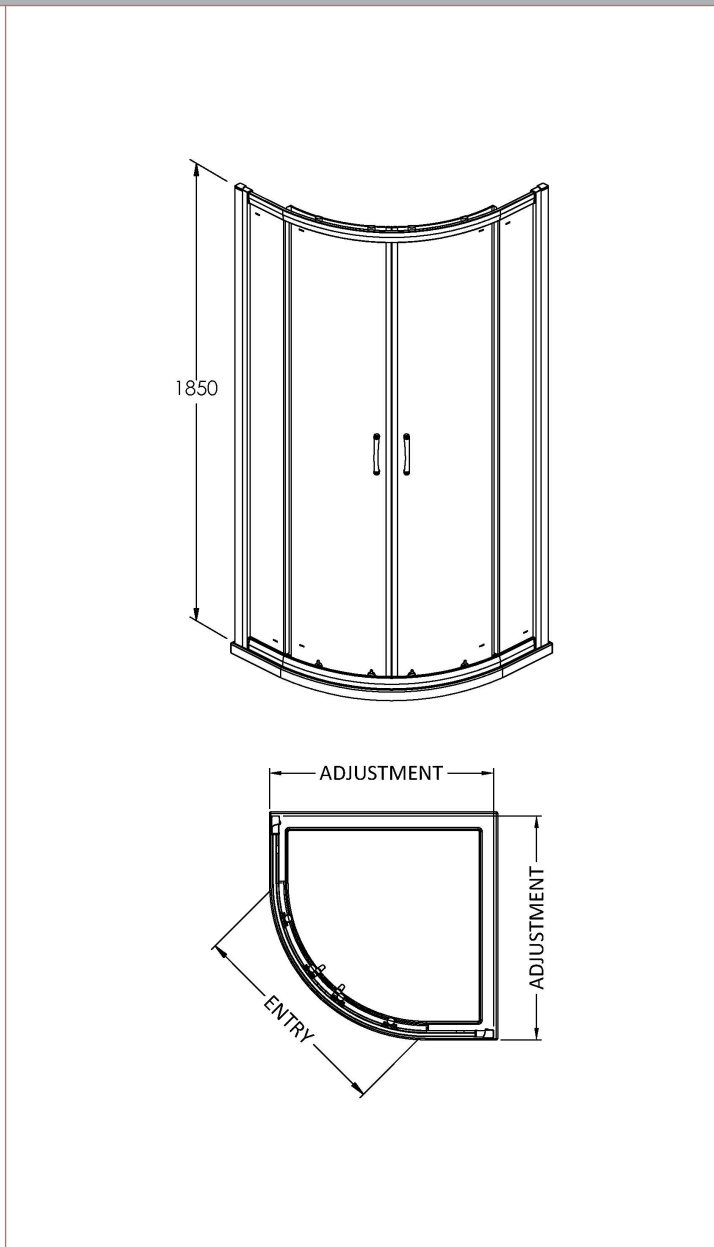

Product Dimensions

Height (mm):	1850
Width (mm):	685
Depth (mm):	685
Nett Weight (kg):	32.1

Packaging Dimensions

Height (mm):	85
Width (mm):	360
Length (mm):	1910
Gross Weight (kg):	32.1

Packaging Data

Box Colour:	Brown Cardboard Box - Printed
Box Qty:	1
Label Size:	100 x 50
Label Colour:	White Label
Label Qty:	2

Outer Box Dimensions (If Applicable)

Height (mm):	
Width (mm):	
Depth (mm):	
Length (mm):	
Gross Weight (kg):	
Barcode:	5055275870976

Product Details

Country of Origin:	China
Fitting Instruction:	No
CE & UKCA:	
Profile Material:	Aluminium
Profile Finish:	Satin Chrome
Adjustments (mm):	665mm - 685mm
Entry Width (mm):	385 mm
Swing In Dim (mm):	N/A
Swing Out Dim (mm):	N/A
Radius (mm):	538 mm
Glass Thickness (mm):	5
Easy Fit:	Yes
Easy Clean:	No
Handle Style:	D Shape Handle
Handle Material:	Plastic
Enclosure Design:	Framed
Wheel Type:	Plastic, Dual, Quick Release
Support Bar Included:	Support Bar Not Included
Extras:	None