

BRISTAN

Installation Instructions & User Guide

Please leave these instructions with the end user

Product Code: JU PULLSNK C (D3)

Specifications

Dynamic Water Pressure

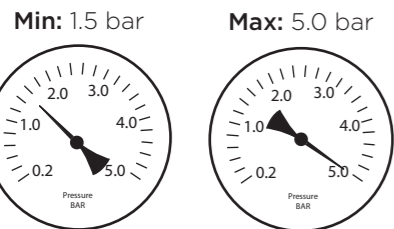

Maximum Static Pressure: 10.0 bar

Inlet Water Temperature

Cold Water Supply

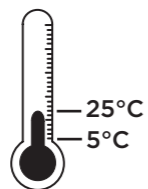

Min: 5°C Max: 25°C

Hot Water Supply

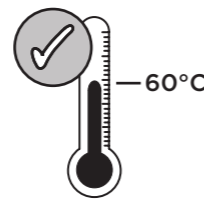

60°C Recommended

Inlet Connections

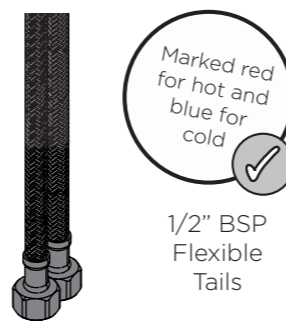

1/2" BSP Flexible Tails

Flexible Connecting Pipes

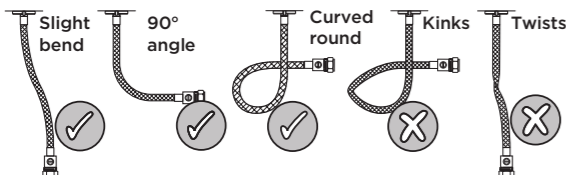

Tools You'll Need

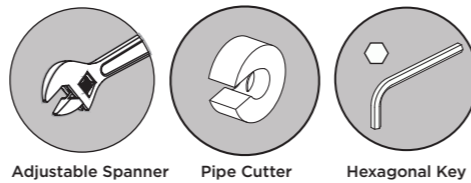

Prior to Installation

All products manufactured and supplied by Bristan are safe to use provided that they are installed, operated and receive regular maintenance in accordance with these instructions.

This product needs to be installed in accordance with, and meet the requirements of the Water Supply (Water Fittings) Regulations 1999 and current by-laws. For full Installation Requirements & Notes (IRN) please visit wras.co.uk/directory.

Isolation valves must be fitted to the inlet water supplies to ensure ease of future maintenance.

Before installing this product the water supply must be thoroughly flushed in order to remove any swarf, solder etc. Full access must be made available for future maintenance/servicing purposes.

This product must not be modified in any way as this will invalidate the guarantee.

If in doubt, contact a registered plumber, your Local Water Authority or the Secretary of the Institute of Plumbing, address as follows:-

The Institute of Plumbing,
64 Station Lane,
Hornchurch,
Essex,
RM12 6NB, Tel: 01708 472791

Pack Contents

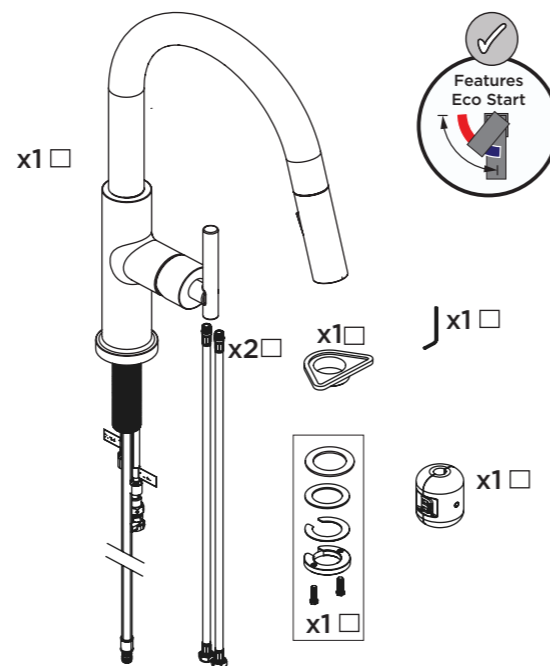

Spare Parts

To replace any spare parts for your tap, why not scan the QR Code or visit www.bristan.com and search for your product.



Warning from Your Water Supplier

It could be a criminal offence to use this tap with a mains water supply drawn directly from the supply pipe (the supply pipe is the one that brings the water supply into your home and is directly connected to the public water main).

This tap has an outlet on a flexible hose, which if immersed in water, could result in contaminated water being back drawn into the pipework if the supply pressure dropped. To prevent contamination of drinking water in the premises and in the water main, and to comply with the legal requirement of the UK plumbing regulations and byelaws, both hot and cold water supplies to this tap must come from a storage cistern.

If the distributing pipes feeding this tap from the storage cistern have other outlets connected to them, the outlet of this tap must be lower than any of those other outlets.

If installed as a tap which is used for drawing water for drinking, and the quality of the water from the storage cistern does not meet the standards for drinking water, a separate tap supplied with wholesome water must be provided for drinking purposes.

For further information, contact the Water Regulations Department of your Local Water Supplier (see WRAS website: wras.co.uk) or contact the Water Regulations Advisory Scheme by email (info@wras.co.uk) or telephone: 0333 207 9030

Installation

1

Feed the pipes through the sink hole and place the tap body.

2a

Feed all pipes through the nut and washers onto the threaded pipe. Tighten screws to secure.

2b

If tap requires further stability, use the reinforcing plate before the fixing kit for extra tolerance.

3

Remove the hose connection by pressing the button and then screw onto the mixing pipe. Re-attach the hose.

4

Open the hose weight and clamp it just before the U-bend, on the section of the hose leading up to the mixed pipe connector

5

Connect the hot and cold water connections. **REMEMBER** hot on the left, cold on the right

IMPORTANT fit isolation valves for future maintenance

6

Switch on the water supply and check connections for any leaks.

Operation/Temperature Control

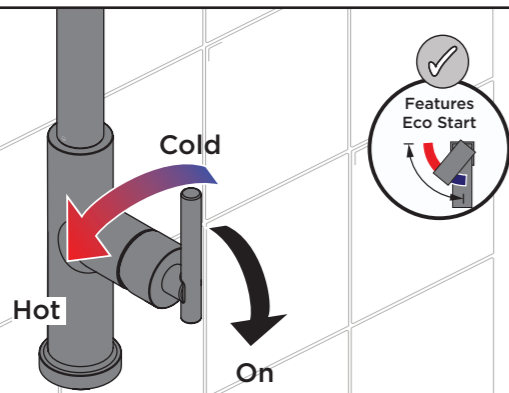

For cold water, position the handle straight upwards. To increase the temperature, turn the handle to the left.

The temperature will gradually rise the further the rotation of the handle.

The handle will cease to turn once it is at a 90° angle, supplying the maximum temperature.

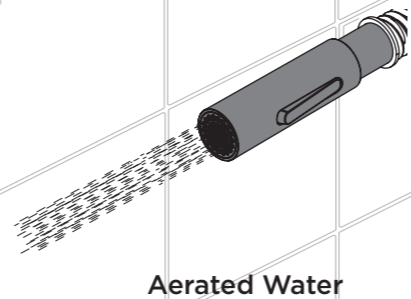
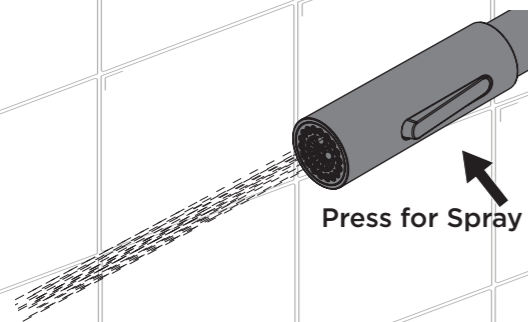

Troubleshooting

Symptom	Cause	Remedy
No flow or low flow rate	Partially closed isolation valve.	Open isolation valve.
	Head of water is below the minimum distance required.	Refer to specification for minimum distance required.
	Hot or cold water being drawn off elsewhere causing pressure changes or instantaneous boiler temperature changes.	Do not use other water outlets when using the taps.
	Airlock or partial blockage in the supply pipework.	Flush through pipework to ensure removal of debris and any airlocks.
Water dripping from taps	This is normal for a short time after using the taps.	This is caused by residual water tension, the build up of water in the tap body.
	If water continues to drip, possibly due to the ceramic disc valves	Remove valves and clean, refer to 'Maintenance' section before starting any maintenance.
Taps do not turn on	Closed isolation valve.	Open isolation valve.
	Mains water supply turned off.	Turn on mains water supply.
Hose doesn't release/re-turn properly	Hose is blocked/kinked/twisted or snagged on other objects.	Isolate the water supply and check the hose for any blockages or defects. Ensure the area is clear so the hose can't get snagged on other objects.
Handset Pressure Changes	Site water pressure is too high for the working pressures listed on the specification.	Install a Pressure Reducing Valve in order to achieve working levels of pressure.

Maintenance - Cleaning/Replacing Cartridge

1

Remove cap. Undo grub screw and remove handle.

2

Unscrew shroud and retaining nut. Remove cartridge.

3

Visit www.bristan.com or scan the QR Code and search for your product code to replace the cartridge for your tap.

4

Reverse the steps to replace the valves and handles.

IMPORTANT
Isolate the water supply before starting!

2.5 mm

Maintenance - Replacing Handset

1

Unscrew handset from hose. Replace with new handset.

IMPORTANT
Isolate the water supply before starting!

Turn on tap to check connections for any leaks.

General Cleaning

Bristan products are made from premium materials, with hand polished, PVD, EPD or electroplated finishes.

Your tap should be regularly cleaned with warm water, a mild pH-neutral liquid soap, and polished with a soft cloth. Any residues from soap, toothpaste, shampoos and shower gels can cause blemishes if not rinsed off straight after use.

Household bleaches and cleaners contain harsh chemicals and may damage the surface finish. Avoid using abrasive cloths, scouring pads, scrub sponges, steel wool or anything similar.

Some surfaces such as nickel and pewter may be affected by the dye found in some cloths, so it is also important to avoid hanging cloths on spouts.

Contact Us

BRISTAN

Bristan Group Ltd.

UK: Bristan Group, B78 1SG.
EU: Masco Europe S.à.r.l.
14 Rue Strachen
6933 Mensdorf
Luxembourg

Customer Service: +44330 026 6273
Web: www.bristan.com
Email: enquire@bristan.com

A Masco Company

Our Guarantee

At Bristan, we want to make things as easy as possible for our customers. That's why we offer solid guarantees on all our products, effective from the date of purchase, to give you peace of mind.

To start your free guarantee simply scan the QR code and register your product. Alternatively visit www.bristan.com/register.

For any other queries, please call our Customer Service on 0330 026 6273 where our expert team of advisors will be able to offer you any help and advice.

For full guarantee terms and conditions visit www.bristan.com/service-centre/guarantees.

