

**NOTICE DE MONTAGE (VERSION COULISSANTE)  
INSTALLATION INSTRUCTIONS (SLIDING VERSION)  
MANUAL DE INSTALACION (VERSION CORREDERA)  
ISTRUZIONI DI MONTAGGIO (VERSIONE SCORREVOLE)  
INSTALLATIE VOORSCHRIFTEN (SCHUIFVERSIE)**

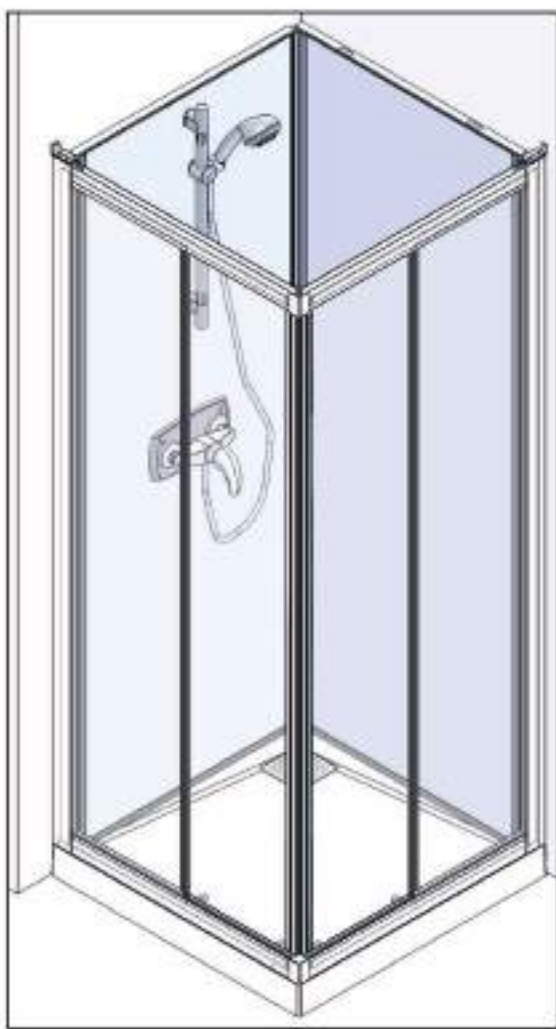

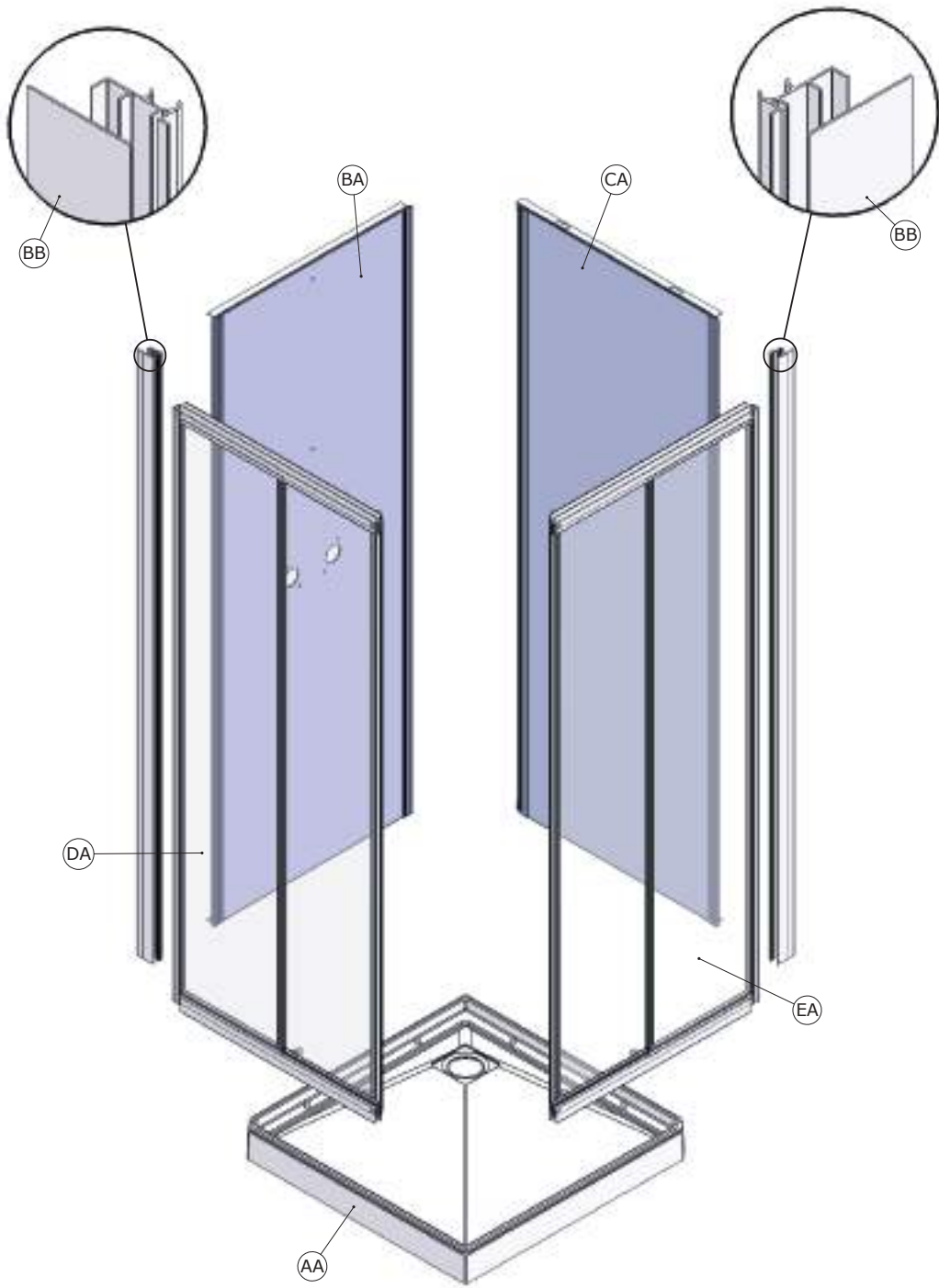

# PIECES DETACHEES / SPARE PARTS / ONDERDELEN

Rep	70 x 70		80 x 80		90 x 90		100 x 80		Qté
	BAS/LOW	HAUT/HIGH	BAS/LOW	HAUT/HIGH	BAS/LOW	HAUT/HIGH	BAS/LOW	HAUT/HIGH	

COLIS 1									
AA	REC417	REC423	REC418	REC424	REC419	REC425	REC420	REC426	1
AB	BOND14								1
AC	TOL54								1
AD	TUY62								1
AE	J686								1

COLIS 2					
BA	CP367	CP369	CP371	CP369	1
BB	5003				2
BC	PPL776				2
BD	VIS41				2
BE	PPL775				2
BF	EQU68				2
BG	CHE02				2
BH	VIS 3,5x25				6
BI	PPL737				1
BJ	PPL738				1
BK	PPL735				1
BL	PPL736				1

COLIS 3					
CA	CP366	CP368	CP370	CP372	1

COLIS 4					
DA	C8718	C8720	C8731	C8720	1
DB	JOI233				1
DC	PPL743				2

COLIS 5					
EA	C8379	C8380	C8381	C8382	1
EB	JOI233				1
EC	PPL743				2

BOITE					
FA	Mitigeur MECA	SET50			1
	Mitigeur THERMO	SET51			1
	FB	TUY60			1
	FC	TUY61			1
	FD	ECR77			6
	FE	VIS200			6
	FF	CAP18			4
	FG	KIT109			1

### Colis 1

S1552

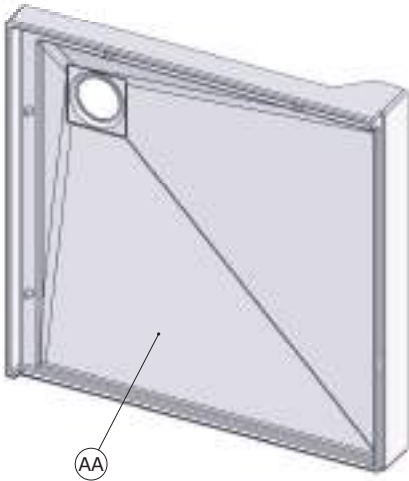

+



### Colis 2

S1555



+



+

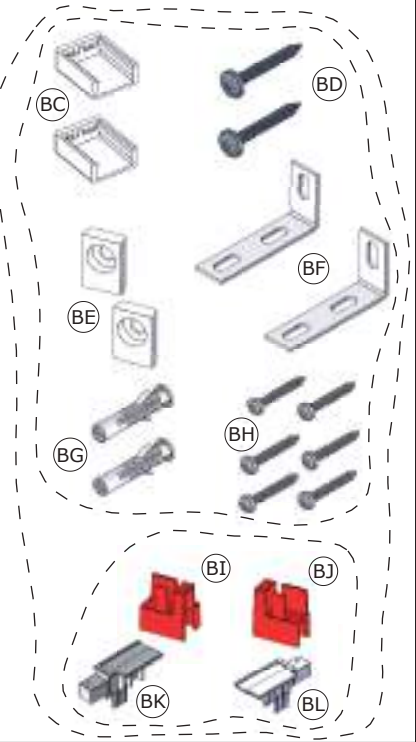

### Colis 3

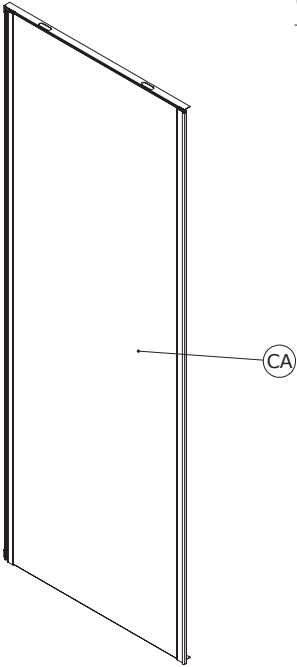

### Colis 4

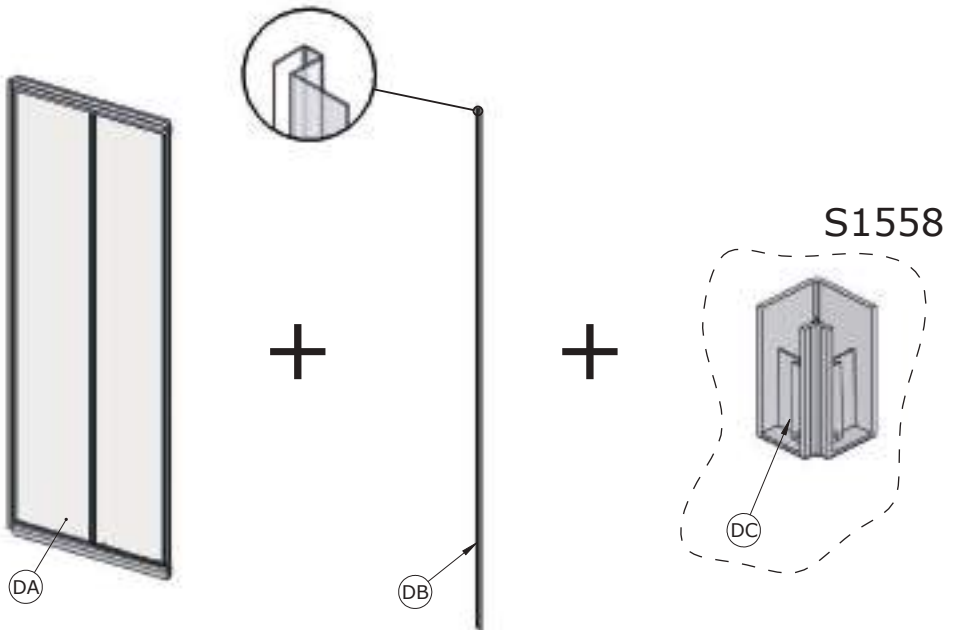

# Colis 5



+



+

S1558

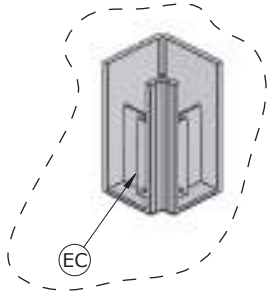

# BOITE

Mitigeur MECA



OU

Mitigeur THERMO



(FA)

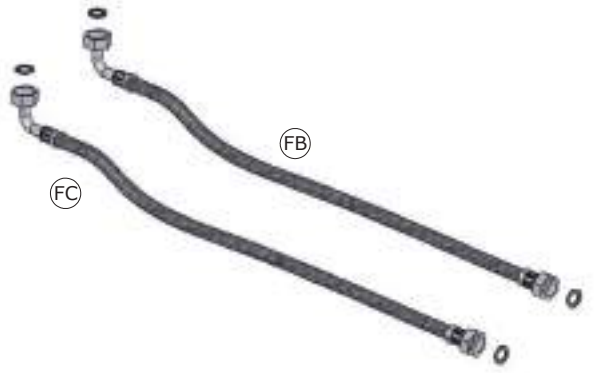

(FB)

(FC)



(FD)



(FE)



(FF)

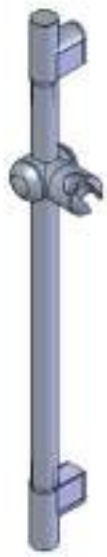

(FG)



① Matériel nécessaire <sup>GB</sup> Tools required <sup>E</sup> Herramientas necesarias  
 ① Materiale necessario <sup>NL</sup> Benodigd gereedschap

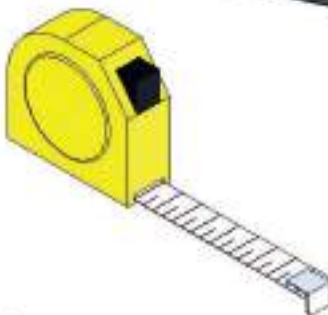
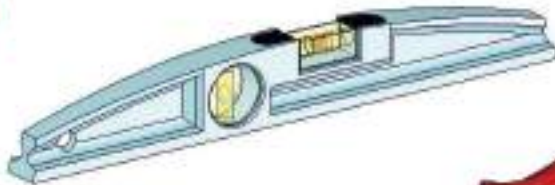

Ø 3 mm



Ø 6 mm



Ø 8 mm



X2



● REVERSIBILITE ● REVERSIBILITY ● REVERSIBILIDAD  
● REVERSIBILITA ● OMKEERBAARHEID

● MONTAGE A GAUCHE  
● LEFT HAND  
● MONTAJE A LA IZQUIERDA  
● MONTAGGIO A SINISTRA  
● MONTAGE LINKS

● MONTAGE A DROITE  
● RIGHT HAND  
● MONTAJE A LA DERECHA  
● MONTAGGIO A DESTRA  
● MONTAGE RECHTS



● Vous avez la possibilité de réaliser un montage à droite ou un montage à gauche. Notre notice d'installation décrit un montage à gauche. Si vous voulez réaliser un montage à droite, il vous suffit d'inverser le montage.

● This cubicle can be installed either left or right hand. These installation instructions show a left hand installation.

● Puede realizar un montaje a la derecha o un montaje a la izquierda. Nuestro folleto de instalación describe un montaje a la izquierda. Si desea montar su cabina a la derecha sólo tendrá que realizar el montaje al contrario.

● Avete la possibilità di effettuare il montaggio a destra o a sinistra. Il nostro manuale descrive il montaggio a sinistra. Se volete realizzare il montaggio a destra è sufficiente invertire varie fasi di montaggio.

● U kunt de douchecabine rechts of links monteren. Onze handleiding beschrijft de links montage van de cabine. Keer de montage om als u de cabine rechts wilt monteren.

01

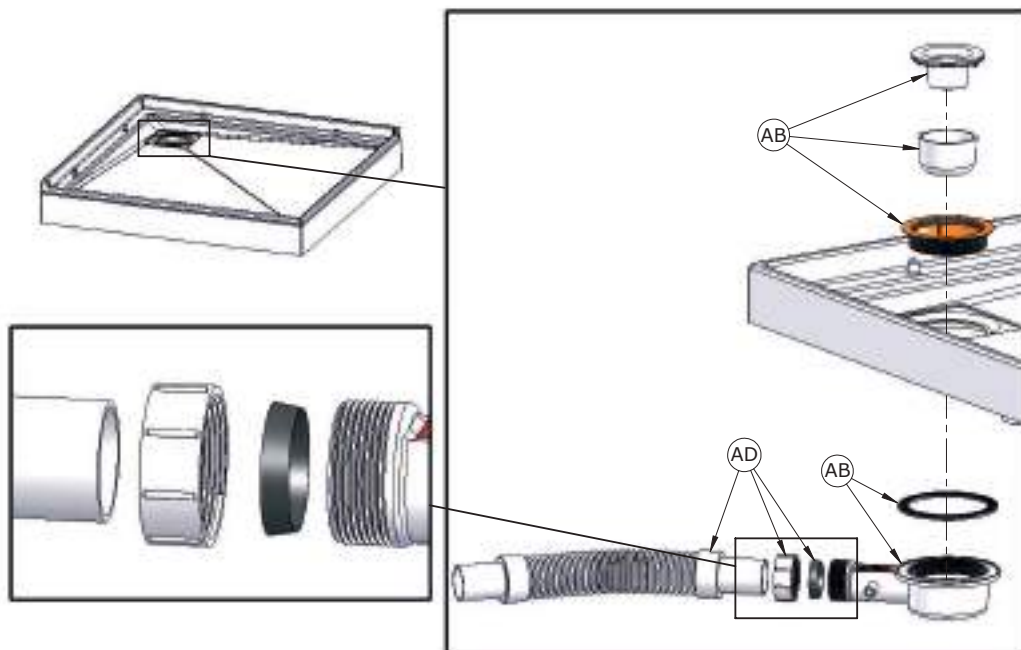

02

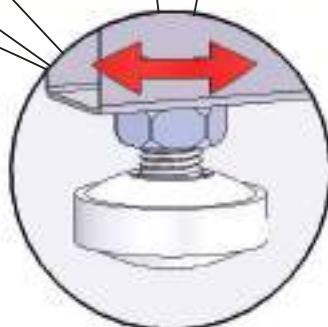
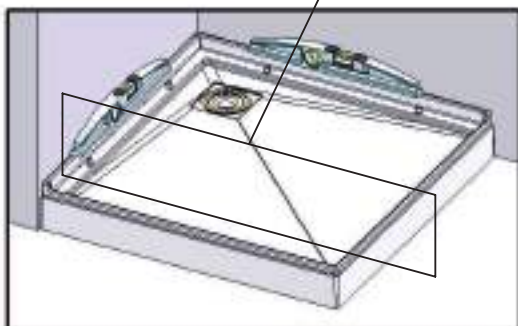
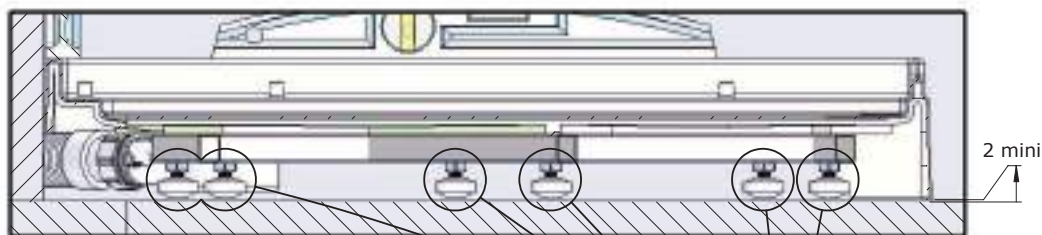

- Pieds avec le sol.
- Feet in contact with the ground.
- Pies en contacto con el suelo.
- Piedi a contatto con il terreno.
- Voeten in contact met de grond.

03

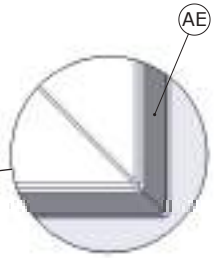
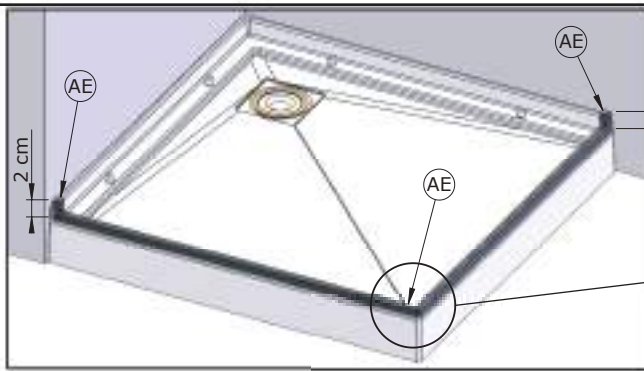

OU  
OR  
O  
OF

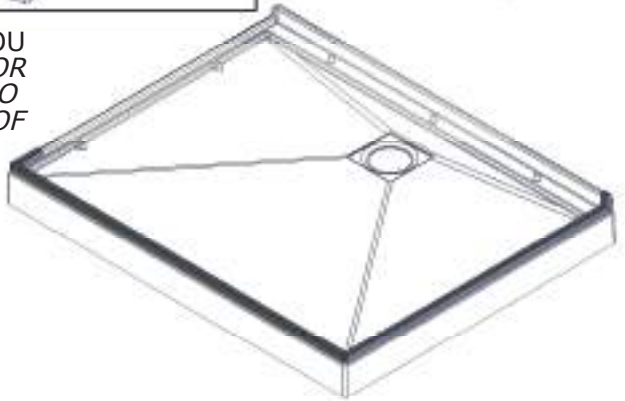

04

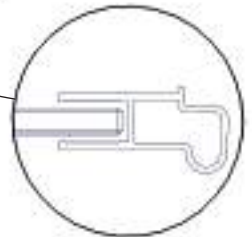
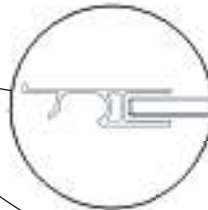
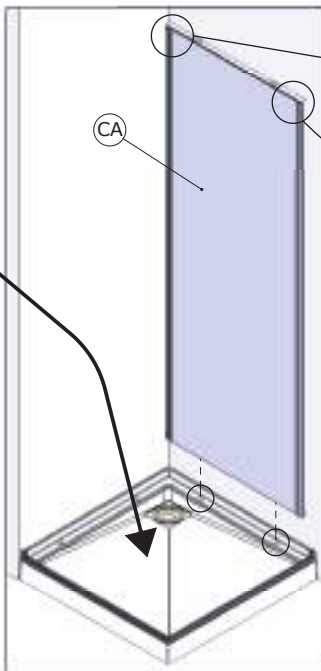

Protéger le receveur  
Protect the shower tray  
Proteggere il piatto  
Proteger el platon  
Scherm de douchebak

05

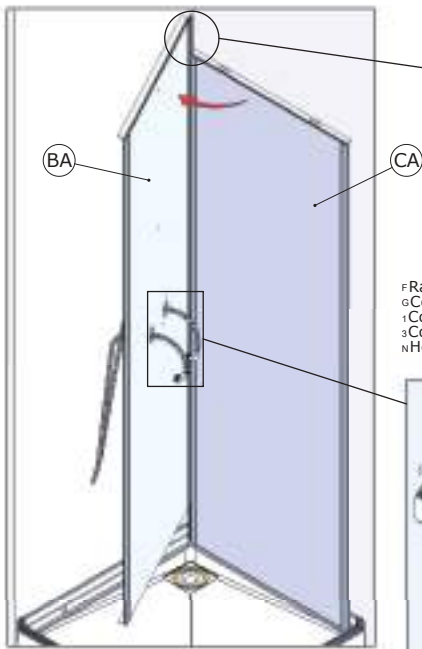

¶Raccorder l'arrivée d'eau et la liaison équipotentielle.  
 ◊Connecting the water inlet and the equipotential link.  
 †Collegare l'ingresso dell'acqua e il collegamento equipotenziale.  
 ‡Conexión de la entrada de agua y la conexión equipotencial.  
 ¶Het aansluiten van de watervoerleiding en de equipotentiaalverbinding.



¶Passer vos flexibles d'alimentation dans les ouvertures prévues.  
 ◊Pass your supply hoses in the planned openings.  
 †Pase los flexibles de alimentación en las aperturas previstas.  
 ‡Passate i tubi flessibili di alimentazione nelle aperture previste.  
 ¶Geven de flexibele leidingen van voedsel in de voorziene openingen.

06

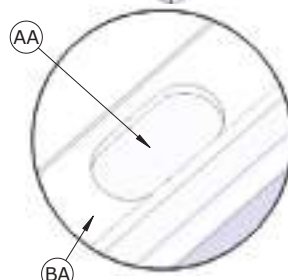
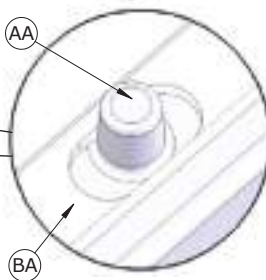
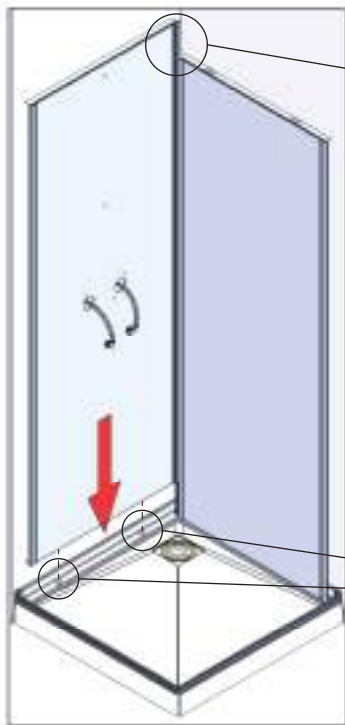

07

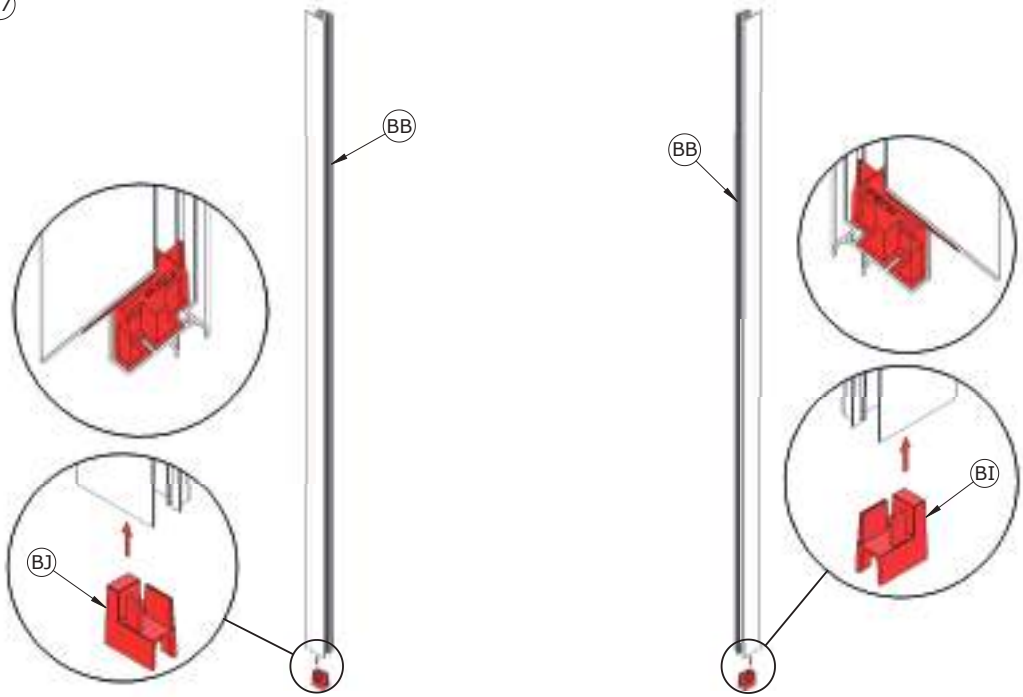

08

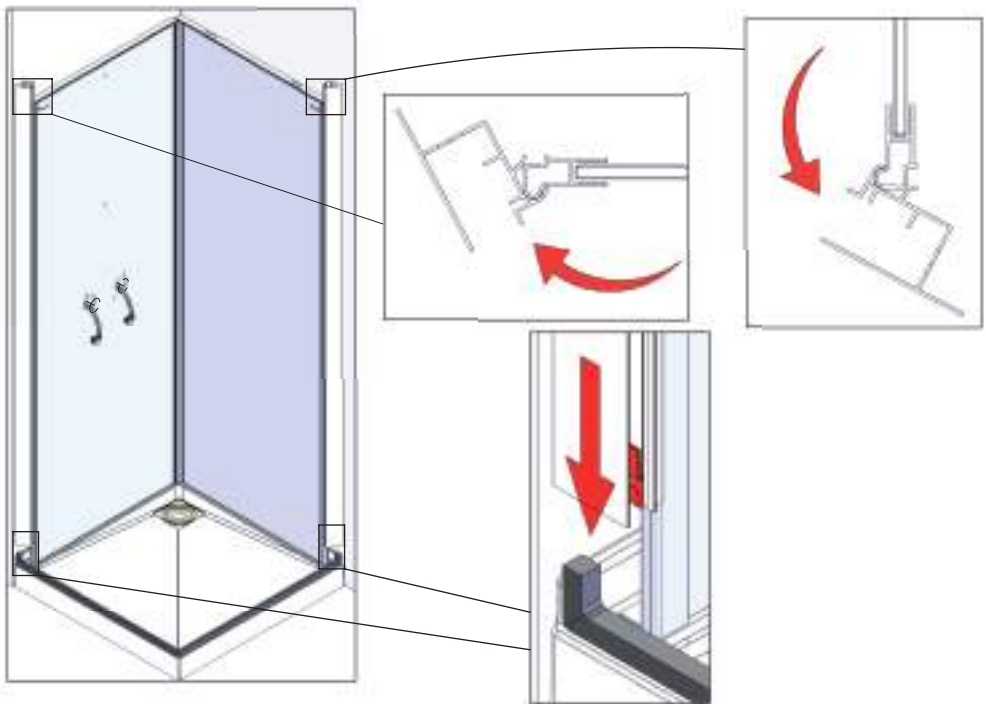

09

Raccorder vos flexibles d'alimentation avec votre mitigeur.  
 Connect your supply hoses with your mixer.  
 Conectar los latiguillos al grifo.  
 Raccordare i flessibili di alimentazione al miscelatore.  
 Sluit de watertoevoerslangen aan de kraan aan.

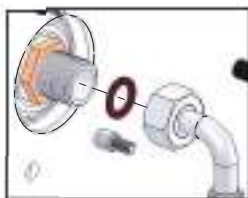
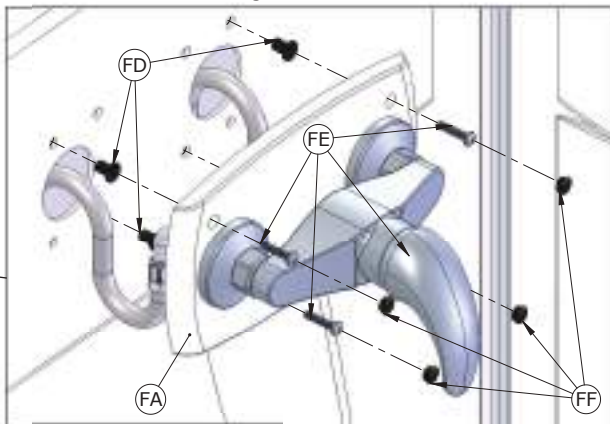
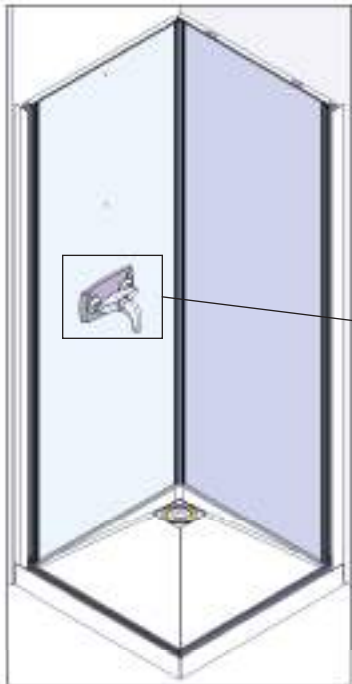

En fonction de votre version, possibilité  
 mitigeur thermostatique.  
 Depending on your version, possibility  
 thermostatic mixer.  
 Según la versión, posibilidad mezclador  
 termostático.  
 Seconda della versione, possibilità  
 miscelatore termostatico.  
 Afhankelijk van de versie, mogelijkheid  
 thermostatische kraan.

10

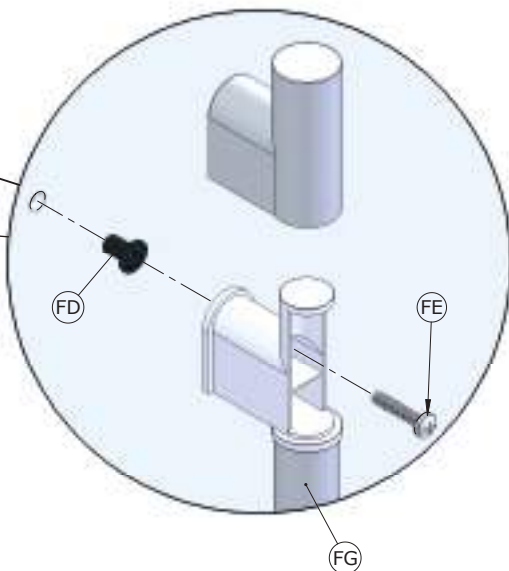
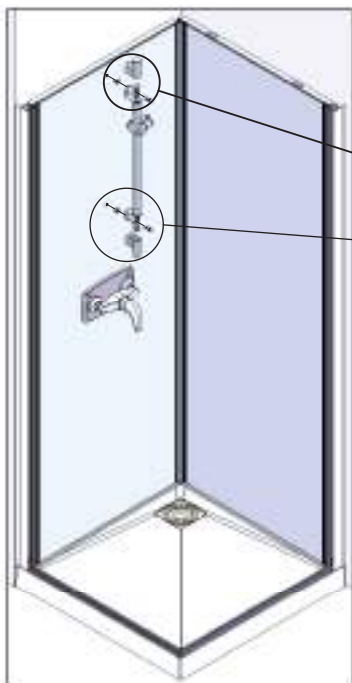

FR - En raison du transport et des diverses manipulations du produit, nous vous conseillons vivement de vérifier le bon serrage de chaque connexion, afin d'éviter tout problème de fuite lors de la mise en eau.

EN - Due to transportation and various product handling issues, we strongly recommend that you check that each connection is properly tightened in order to avoid any potential leakage problems when put under pressure.

ES - Debido al transporte y a las distintas manipulaciones del producto, le aconsejamos comprobar que sujeción de cada conexión sea correcta, para evitar los problemas de fuga una vez se conecte con el agua.

IT - A causa del trasporto e delle diverse manipolazioni del prodotto, vi consigliamo vivamente di controllare il buon serraggio di tutti i collegamenti allo scopo di evitare perdite d'acqua.

NL - Door het transport en de diverse logistieke handelingen met het product dient u elke slangconnectie (koppeling/aansluiting) extra te controleren op waterdichtheid alvorens u de douchecabine definitief plaatst. Hiermee vermijdt u mogelijke lekkages nadat het water op druk wordt aangesloten.

⑫

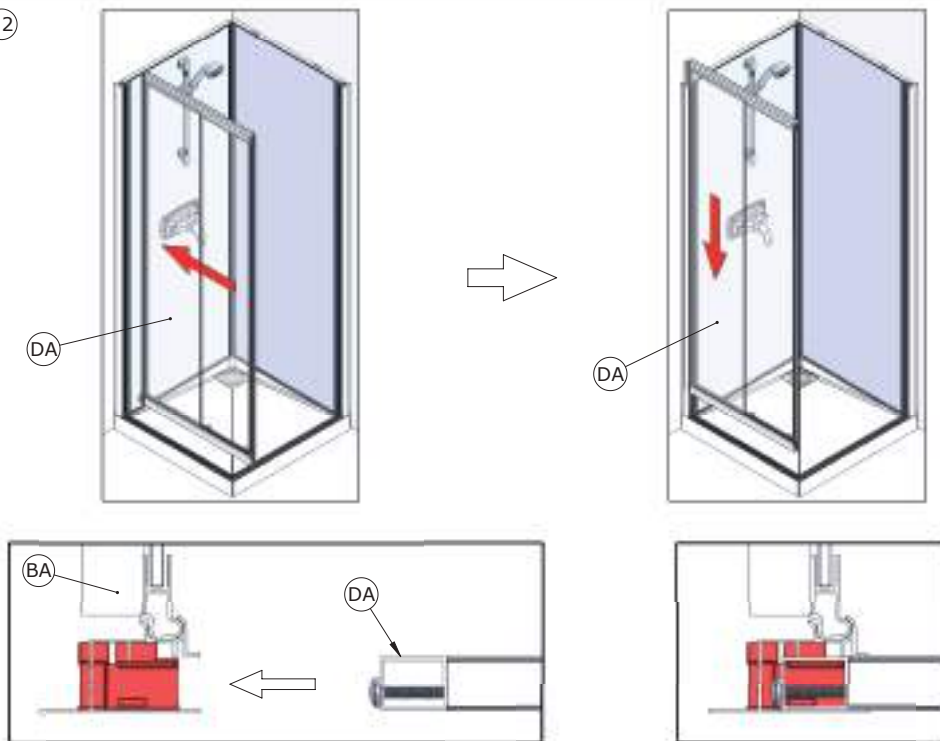

⑬

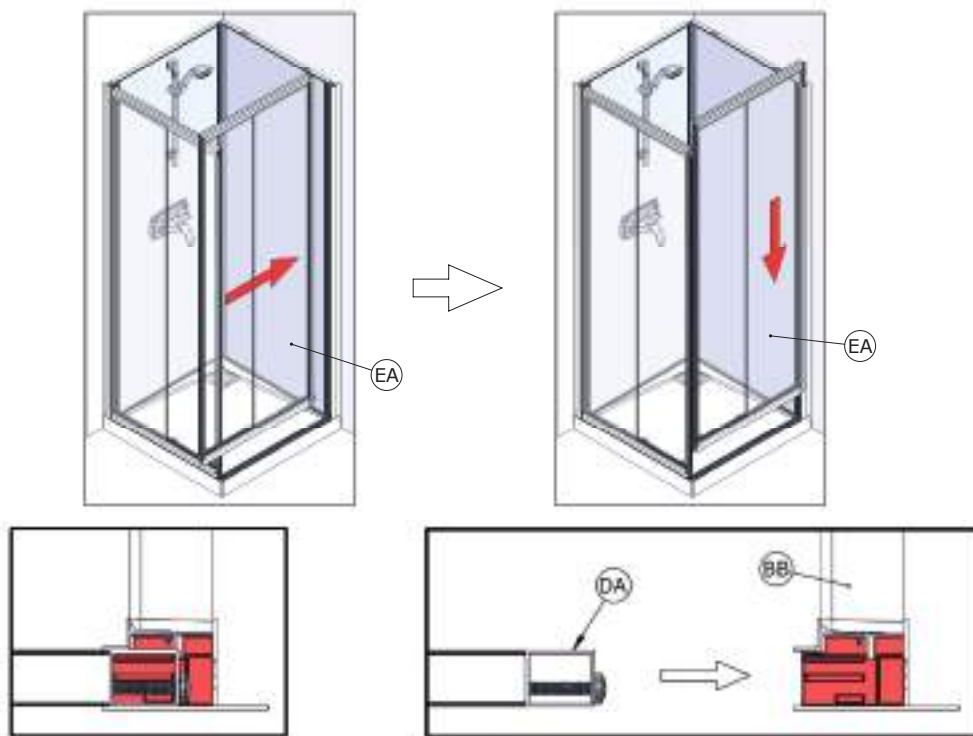

⑭

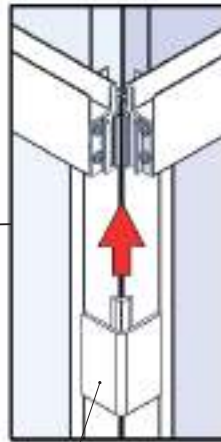

DC

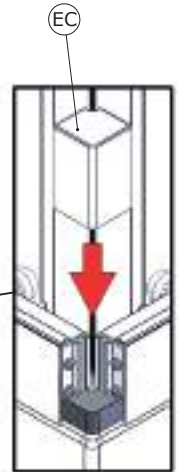

EC

⑮

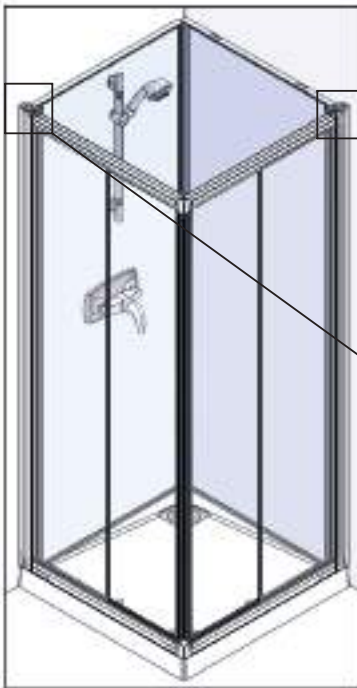

BL

UP R

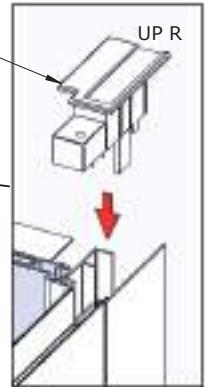

BK

UP L

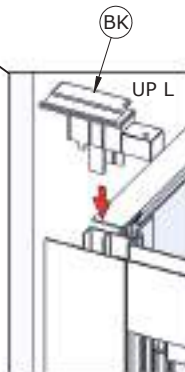

①⑥

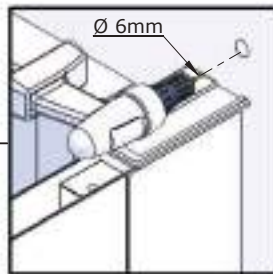
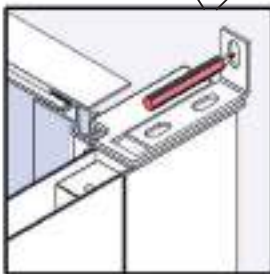
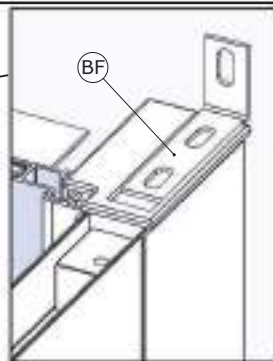
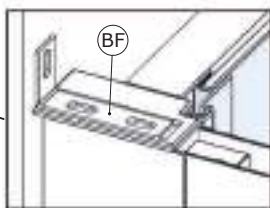

①⑦

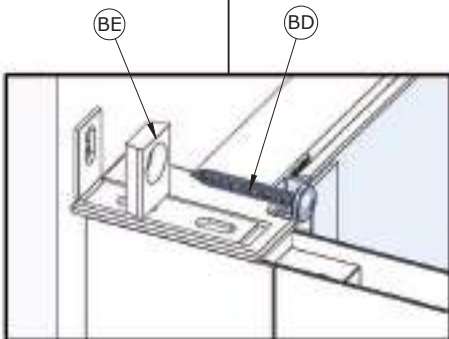
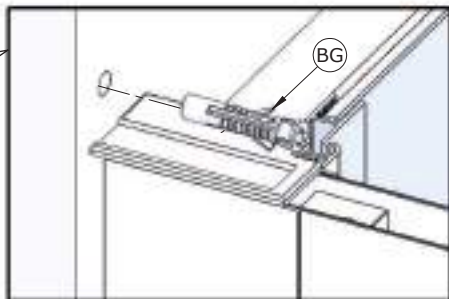

18

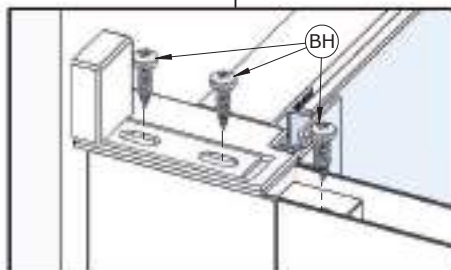
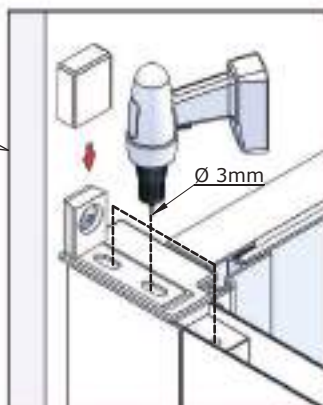
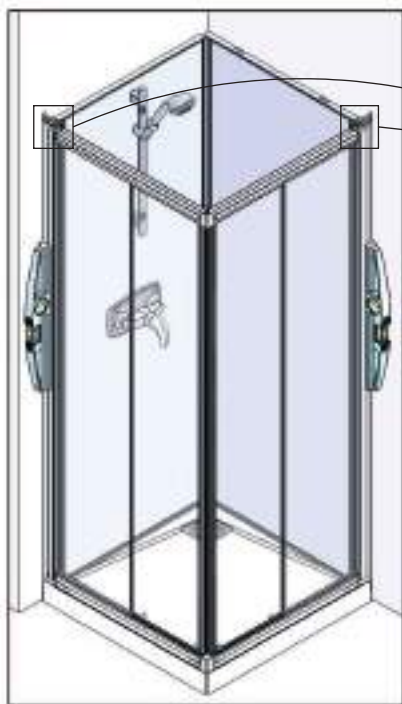

19

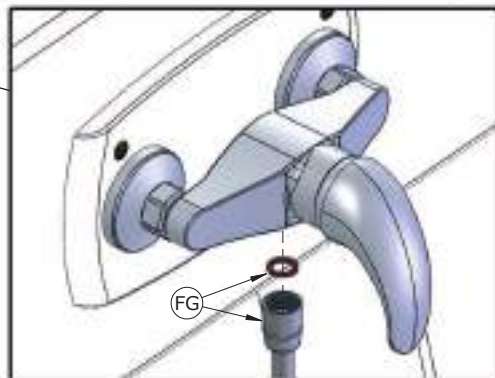
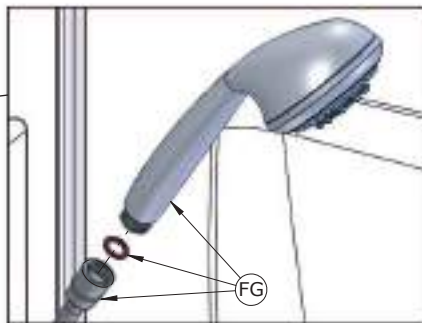
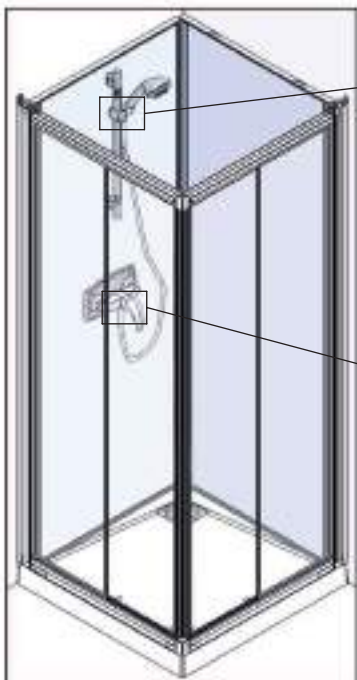

(20)

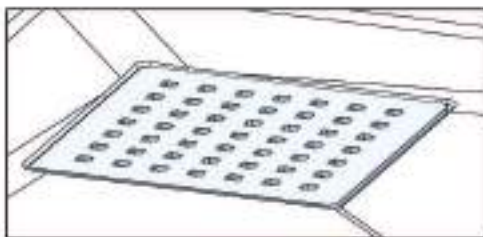

(21)

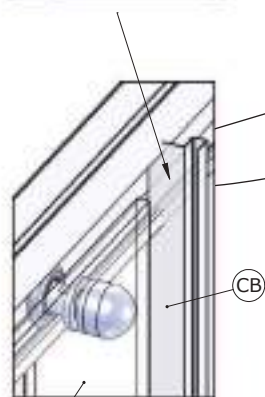

Porte coulissante  
Sliding door  
Puerta corrediza  
Porta scorrevole  
Schuifdeur

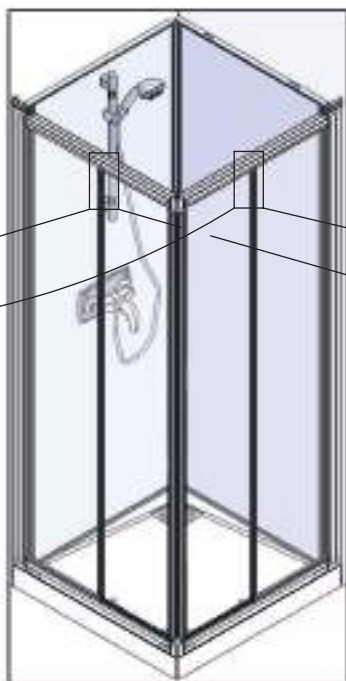

Verre fixe  
Fixed glass  
Parte fissa  
Parte fija  
Vaste glas

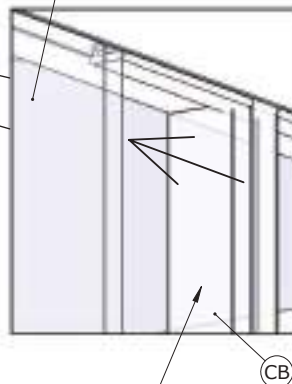

(22)

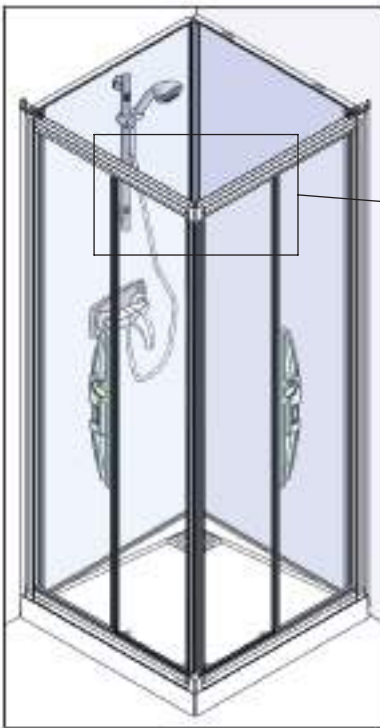

x8

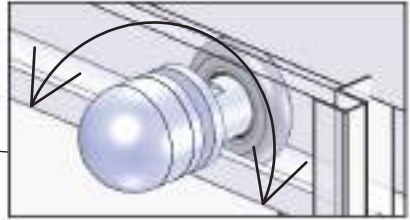

Régler les portes afin qu'elles soient de niveau  
 Adjust the doors so that they are level  
 Regolare le porte in modo che siano in bolla  
 Ajustar las puertas de manera que estén niveladas



-F-

POUR LA PROTECTION ELECTRIQUE DE VOTRE DOUCHE, IL EST NECESSAIRE DE RELIER LES ORGANES METALLIQUES DE VOTRE PRODUIT AU CIRCUIT EQUIPOTENTIEL DE VOTRE INSTALLATION.

VOUS POUVEZ CONTACTER VOTRE INSTALLATEUR HABITUEL, IL SAURA VOUS CONSEILLER.



-GB-

FOR THE ELECTRONIC PROTECTION OF YOUR SHOWER, THE METAL PARTS OF YOUR PRODUCT SHOULD BE CONNECTED TO THE EQUIPOTENTIAL CIRCUIT OF YOUR INSTALLATION.

CONTACT YOUR USUAL SHOWER FITTER FOR ADVICE.

-NL-

VOOR DE ELEKTRISCHE BESCHERMING VAN UW DOUCHE MOETEN DE METALEN DELEN VAN UW PRODUCT WORDEN AANGESLOTEN OP HET EQUIPOTENTIALE CIRCUIT VAN UW INSTALLATIE.

NEEM HIERVOOR CONTACT OP MET UW NORMALE INSTALLATEUR, HIJ KAN U ADVISEREN.

-I-

PER GARANTIRE LA PROTEZIONE ELETTRICA DELLA DOCCIA OCCORRE COLLEGARE LE PARTI METALLICHE AL CIRCUITO EQUIPOTENZIALE DELL'APPARECCHIO.

CHIEDERE CONSIGLIO ALL'ELETTRICISTA DI FIDUCIA

-ES-

PARA LA PROTECCIÓN ELÉCTRICA DE SU DUCHA, SERÁ NECESARIO CONECTAR LOS ELEMENTOS METÁLICOS DE SU PRODUCTO AL CIRCUITO EQUIPOTENCIAL DE SU INSTALACIÓN.

PÓNGASE EN CONTACTO CON SU INSTALADOR HABITUAL, ÉSTE SABRÁ ACONSEJARLE.







**SAV**  
**SERVICE HELPLINES**  
**ASSISTENZA POST-VENDITA**  
**SERVICIO POSTVENTA**

**FRANCE**

02 40 21 29 45

**SCHWEIZ**

(01) 748 17 44

**UK**

020 8842 0033

**ESPANA**

93 544 60 76

**IRELAND**

04697 33102

**NEDERLAND**

0475 487 100

**DEUTSCHLAND**

0800 82 27 82 0

**BELGIE**

+31 475 487 100

**ITALIA**

(0382) 6181

**BELGIQUE**

+31 475 487 100

**OSTEREICH**

(0222) 21 402 16 0

**РОССИЯ**

963 19 40, 773 67 22