

Sales Code: LQ501

Description: 700X500 Led Mirror

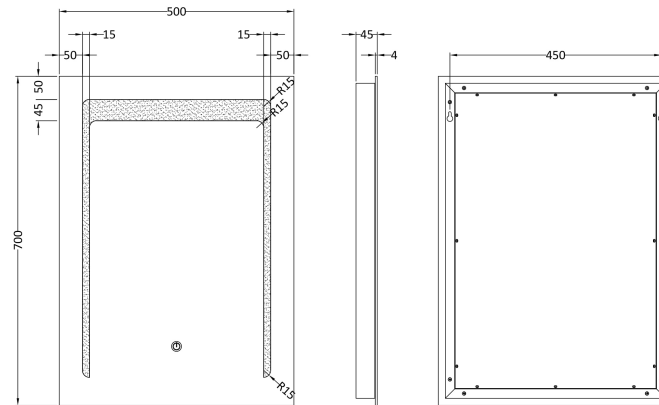
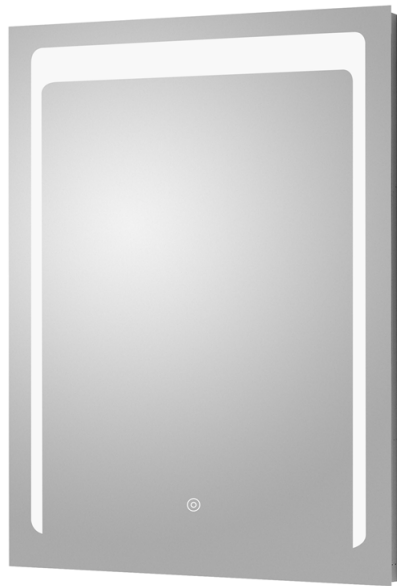

Product Dimensions

Height (mm):	700
Width (mm):	500
Depth (mm):	
Nett Weight (kg):	5

Packaging Dimensions

Height (mm):	105
Width (mm):	613
Depth (mm):	823
Gross Weight (kg):	7

Packaging Data

Box Colour:	Brown Cardboard Box - Printed
Box Qty:	1
Label Size:	x
Label Colour:	Not Applicable
Label Qty:	

Outer Box Dimensions (If Applicable)

Height (mm):	
Width (mm):	
Depth (mm):	
Gross Weight (kg):	
Barcode:	5056211890607

Product Details

Country of Origin:	China			
Fitting Instruction:	No			
Certification:	CE: Yes	FSC: No	WEEE: Yes	RoHS: Yes
	EMC: Yes	LYD: Yes	ECOMP:	ECIRC:

Product Material:	Aluminium
Colour/Finish:	
No of Shelves:	0
Fixings Included:	Yes
Light Power Source:	Mains Supply
No of Lights:	1
Bulb Type:	Led 6000K
Voltage:	12
Operation Method:	Touch Sensor
Bulb Watt:	20
Product Features:	Demister
Illuminated:	Yes