

# cold water pack

**COLD WATER CONTROL PACK KIT COMPRISES OF:**



**B**

Pressure Reducing Valve  
(with combined line strainer)

**C**

Inline  
Check Valve

**D**

Hot Water  
Expansion Vessel

**Ref: 87783101 CWP Cold water control pack**  
for use with 10, 15 & 25 litre unvented stored water heater installations

Installation Guide: 2.8mtrs (for 10 litre models) and 4.2mtrs (for 15 litre models) of uninterrupted 15mm copper water pipe, before the first draw off point, is required to accommodate the heaters hot water expansion. Please refer to your water heater installation instructions to confirm installation requirements.

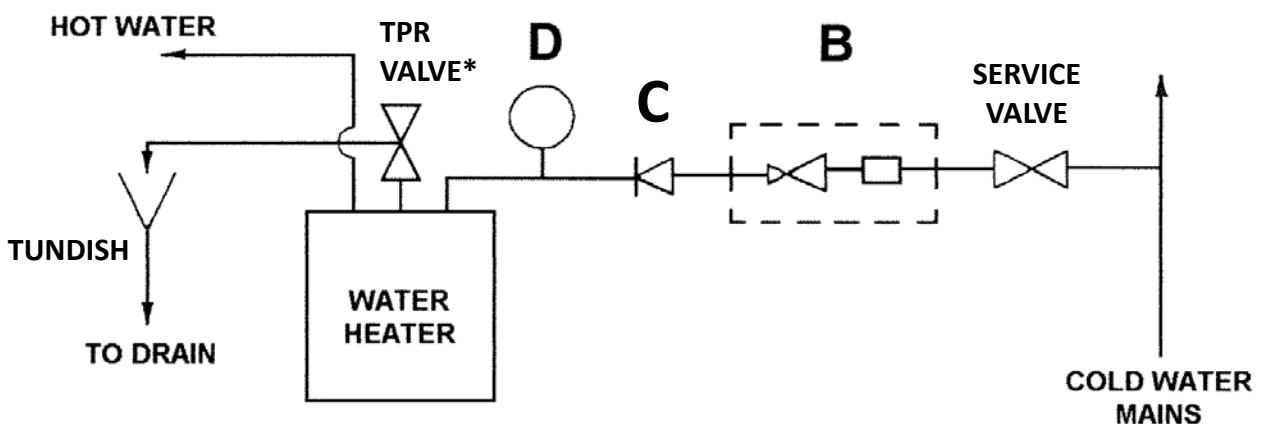

**\*TEMPERATURE & PRESSURE RELIEF VALVE (supplied factory fitted on MW units)**  
**EW, TS and MS units (supplied with an accompanying PRV)**