

Sales Code: NCG341

Description: Freya Wall Hung Pan & Sc Seat (Pp)

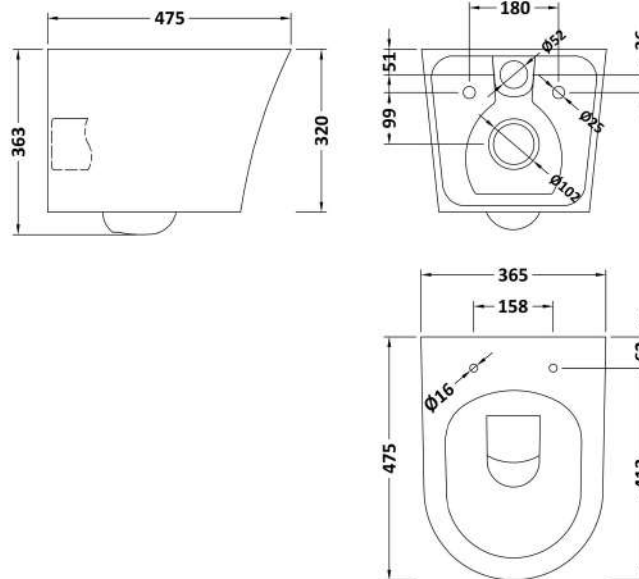

Product Dimensions

Height (mm):	363
Width (mm):	365
Depth (mm):	495
Nett Weight (kg):	24

Packaging Dimensions

Height (mm):	420
Width (mm):	395
Depth (mm):	540
Gross Weight (kg):	25

Packaging Data

Box Colour:	Brown Cardboard Box
Box Qty:	1
Label Size:	100 x 50
Label Colour:	White Label
Label Qty:	2

Outer Box Dimensions (If Applicable)

Height (mm):	
Width (mm):	
Depth (mm):	
Gross Weight (kg):	
Barcode:	5056462694832

Product Details

Country of Origin:	China
Fitting Instruction:	No
Certification: CE & UKCA:	No
WRAS:	N/A
WRAS No:	N/A
Product Material:	Vitreous China
Fixing Supplied:	No

Pans/Bidets: Trap Style: Includes Seat: Yes

Seats: Seat Type: Sandwich Material: Polypropylene
 Function: Soft Close Hinge Type: Top Fix
 Hinge Material: Metal

Cisterns: Operating Type: Not Applicable Fittings: Not Applicable
 Lever Type: N/A

Basins: Tap Hole: Not Applicable Chain Stay Hole: Not Applicable
 Template: Not Applicable Waste Type Req: Not Applicable
 Overflow Inc: Not Applicable Overflow Cover: Not Applicable
 Inner Bowl Depth (mm): N/A