

Sales Code: NLT91053

Barcode: 5056462656373

Brand: nuie

Description: 1600 x 800mm Black Slate Rectangular Slimline Shower Tray

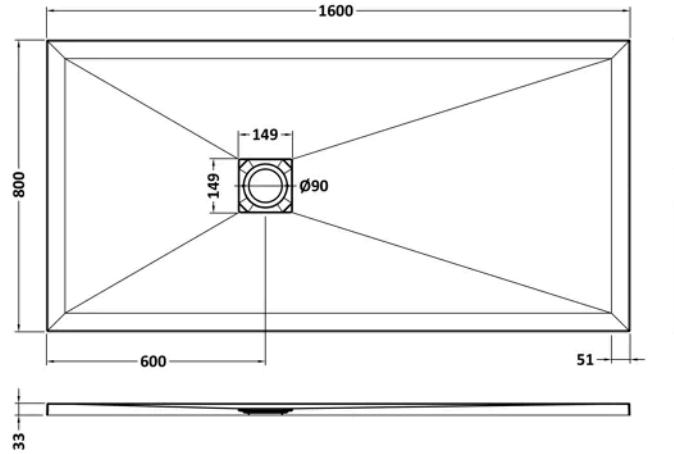

Product Dimensions

Product	32 x 800 x 1600mm (H x W x L)
Packaged	73 x 840 x 1640mm (H x W x D)
Nett Weight	57.4 kg
Packaged Weight	57.7 kg

Product Details

Country of Origin	United Kingdom
Product Material	Acrylic Capped Abs Caco3 And Pu
Colour/Finish	Black Slate
Style	Contemporary
Ce Certified	Yes
Leg Set Included	No
Legs Included	No
Slip Resistant	No
Waste Included	No
Waste Shape	Square
Waste Size Required	90mm