

**Sales Code:** NLT91054

**Barcode:** 5056462656403

**Brand:** nuie

**Description:** 1600 x 900mm Black Slate Rectangular Slimline Shower Tray

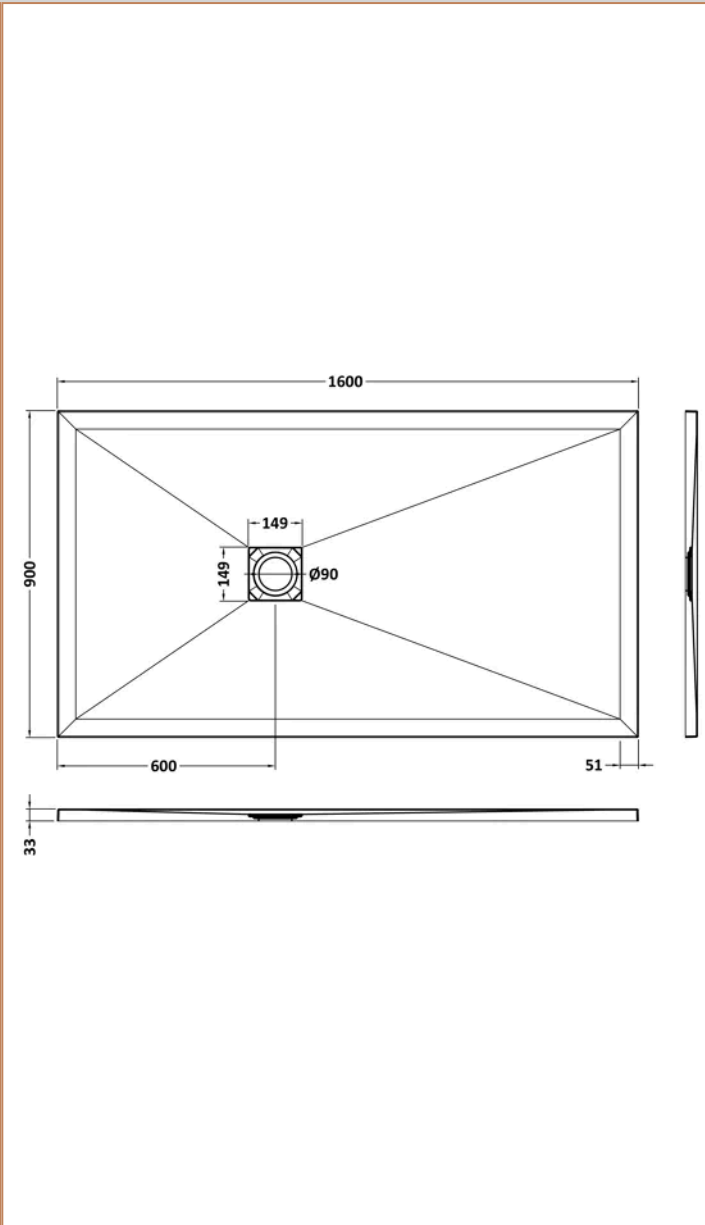

### Product Dimensions

Product	32 x 900 x 1600mm (H x W x L)
Packaged	73 x 940 x 1640mm (H x W x D)
Nett Weight	62.7 kg
Packaged Weight	63 kg

### Product Details

Country of Origin	United Kingdom
Product Material	Acrylic Capped Abs Caco3 And Pu
Colour/Finish	Black Slate
Style	Contemporary
Ce Certified	Yes
Leg Set Included	No
Legs Included	No
Slip Resistant	No
Waste Included	No
Waste Shape	Square
Waste Size Required	90mm