

Sales Code: NWFL1990BB

Barcode: 5056883732465

Brand: nuie

Description: 900x1950 Fluted Wetroom Screen Inc' BAR

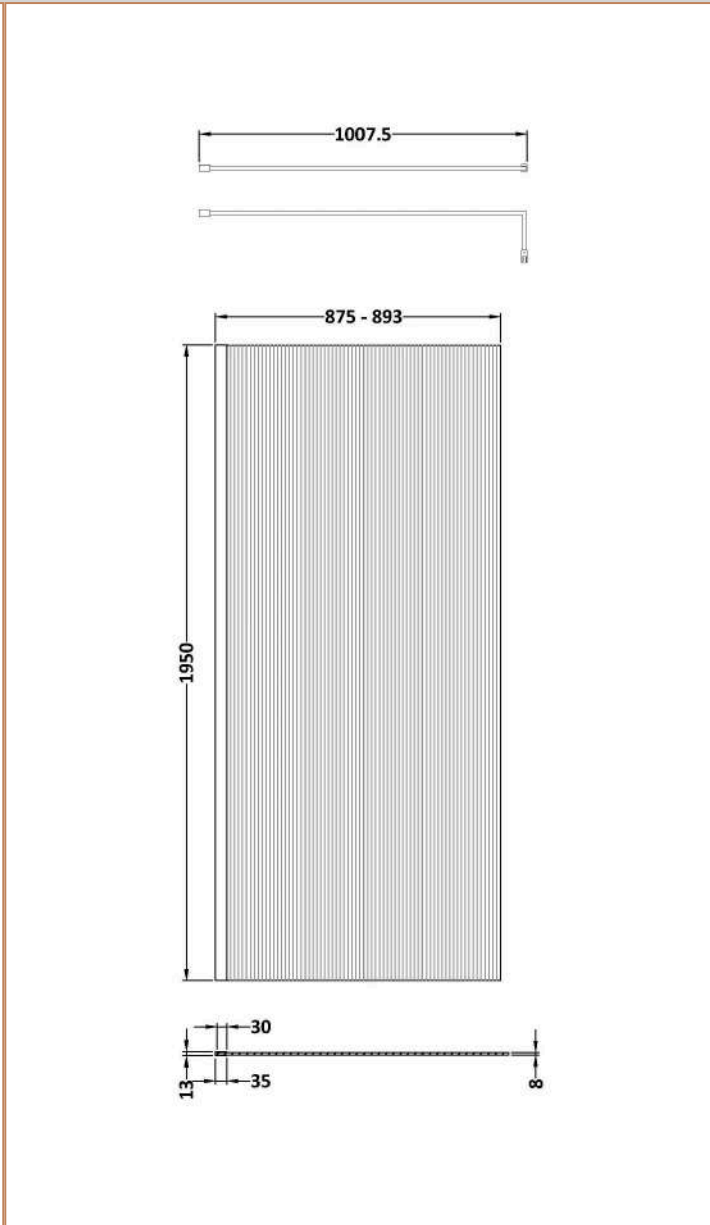

Product Dimensions

Product	2070 x 950 x 1970mm (H x W x D)
Packaged	2070 x 950 x 60mm (H x W x D)
Nett Weight	40.3 kg
Packaged Weight	40.3 kg

Product Details

Country of Origin	China
Product Material	Aluminium
Colour/Finish	Brushed Brass
Style	Contemporary
Easy Clean	Yes
Adjustment Max	893
Adjustment Min	875
Ce Certified	Yes
Declaration Of Performance	Yes
Easy Fit	No
Enclosure Design	Semi-Frameless
Frame Finish	Brushed Brass
Glass Thickness	8 mm
Handles Included	No
Ukca Certified	Yes

Sales Code:
WRFL19590

Barcode: 5056462661254

Brand: Hudson
Reed

Description: Synergy 900mm Semi-Frameless Chrome Fluted Wetroom Screen With Support Bar

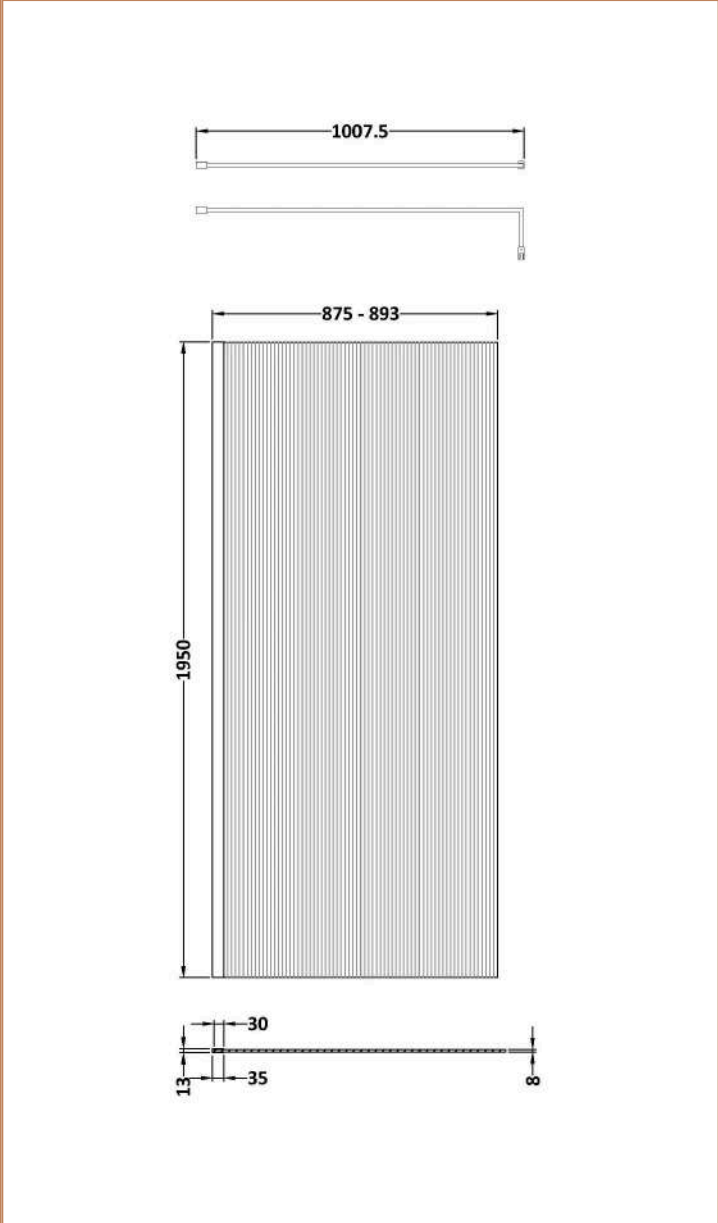

Product Dimensions	
Product	1950 x 900 x 14mm (H x W x D)
Packaged	2070 x 950 x 60mm (H x W x D)
Nett Weight	40.3 kg
Packaged Weight	40.3 kg
Packaging Details	
Label Size (mm)	50 x 100
Product Details	
Country of Origin	China
Product Material	Aluminium
Colour/Finish	Chrome
Style	Contemporary
Easy Clean	Yes
Adjustment Max	893
Adjustment Min	875
Ce Certified	Yes
Declaration Of Performance	Yes
Easy Fit	No
Enclosure Design	Semi-Frameless
Frame Finish	Chrome
Glass Thickness	8 mm
Handles Included	No
Support Bar Included	Yes
Ukca Certified	Yes

Sales Code: WRSF015

Barcode: 5056462611860

Brand: Hudson Reed

Description: Hudson Reed Brass 1950mm Wetroom Wall Channel

Product Image Not Available

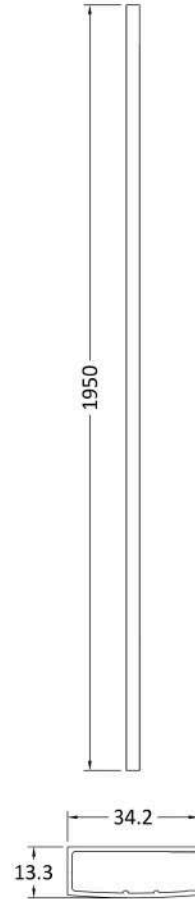

Product Dimensions

Product	1950 x 34 x 13mm (H x W x D)
Packaged	45 x 185 x 1970mm (H x W x D)
Nett Weight	0.8 kg
Packaged Weight	0.8 kg

Product Details

Country of Origin	China
Product Material	Aluminium
Colour/Finish	Brass
Style	Contemporary

Sales Code: FIX025

Barcode: 5056462611884

Brand: nuie

Description: Nuie Brushed Brass Wetroom Screen Support Arm

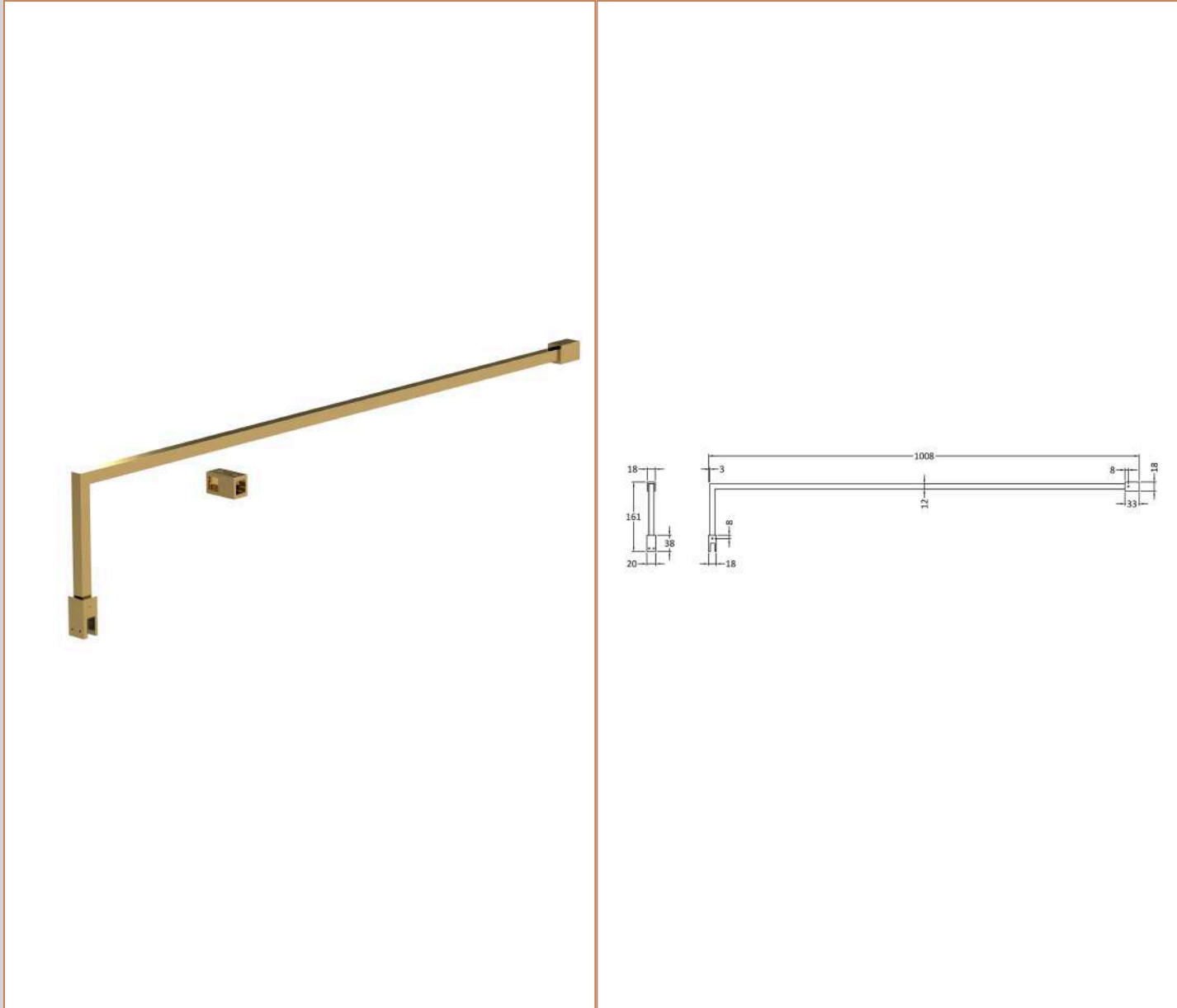

Product Dimensions

Product	15 x 150 x 1000mm (H x W x D)
Packaged	35 x 160 x 1020mm (H x W x D)
Nett Weight	0.67 kg
Packaged Weight	0.7 kg

Product Details

Country of Origin	China
Product Material	Stainless Steel
Colour/Finish	Brushed Brass
Style	Contemporary