

1/2" Basin Taps

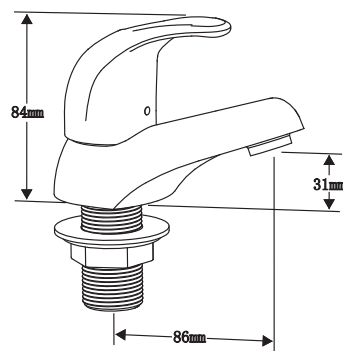

3/4" Basin Taps

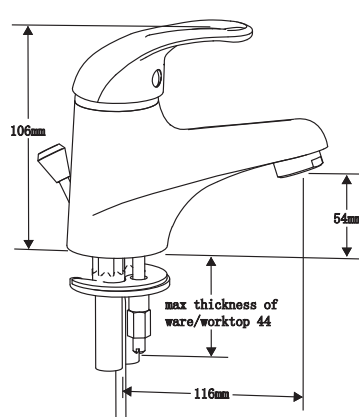

SL Mono Basin

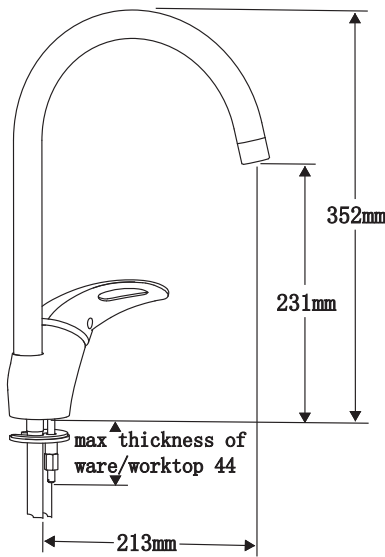

S/A Mono Sink Mixer

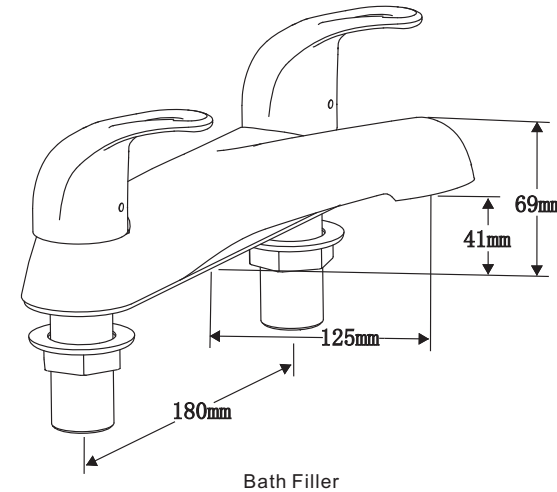

Bath Filler

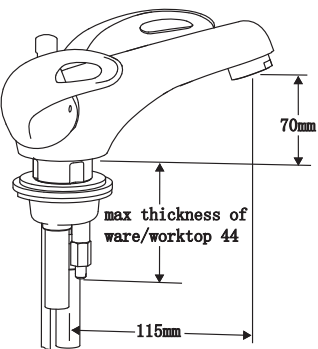

DC Mono Basin

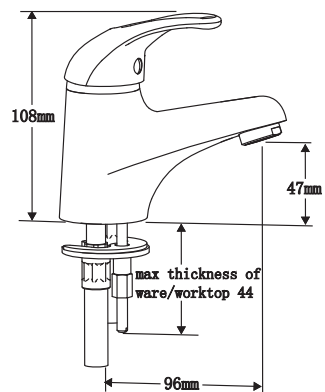

SL Mini Mono Basin

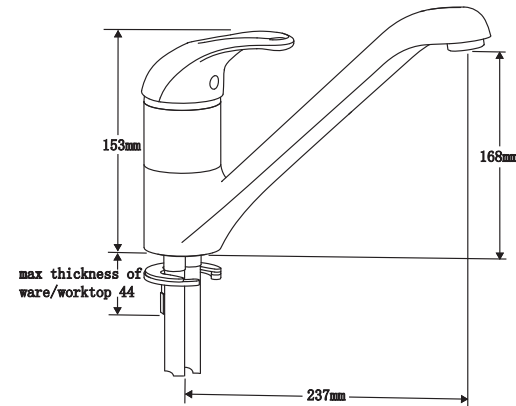

Mono Sink Mixer

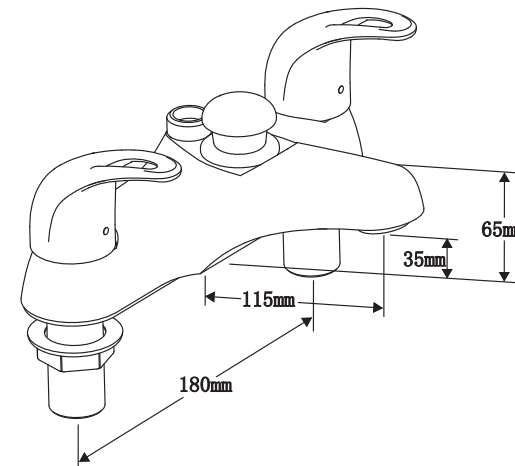

Bath Shower Mixer

Water Regulations Requirements

It is important to ensure that the water supplies to your taps and mixers are connected in accordance with the water regulations (WRAS) requirements and good plumbing practice.

It is Pegler's recommendation and good plumbing practice that the supplies of hot and cold water to the products should be at equal (balanced) pressures in order to provide a consistent flow. Supplies should be from a common source, either mains or tank fed. If supplies are not equal pressures then non return valves should be fitted (supplied).

This products has been designed to function on all types of water systems

Please Note: If a pump is to be installed to boost gravity supplies please refer to the pump manufactures instructions.

The hot and cold inlets for any of the products are hot on the left and cold on the right when viewed from the front of the fitting. It is our recommendation and good plumbing practice that a service valve also (Pegler PB300) should be installed upstream in the inlet supply lines.

Pipe Connections

IMPORTANT. Before making any inlet pipe connections all supplies **MUST** be thoroughly flushed to remove any debris. Failure to do so could result in damage or low flow from the mixing valve. It is a requirement of Byelaw 55 of the Water Fittings Byelaw Scheme that this function is undertaken before making any pipe connections to supplies.

General Installation Notes

- Care must be taken during installation to prevent any risk of damage to the product or injury to installer.
- Installation must be carried out by a qualified and competent person and in accordance with the instructions supplied.
- Installations must comply with all Local and National Water Authority Regulations, and Building/Plumbing Regulations.
- Please ensure that you have read and understood all sections of this manual before Installation.

Water Supply Pressures

Leger fittings have been designed to function under the following conditions:

- Minimum supply pressure 0.1 bar.
- Maximum supply pressure 6.0 bar.

Generous flow rates are achieved at pressures as low as 0.1 bar. At high pressures it may be necessary to reduce excessive flow rates by fitting stop or servicing valve in the supply line before the mixer or tap. These stop valves facilitate ease of maintenance should it be Necessary.

Please Note: The mono basin mixer L565 is supplied with flow straightener fitted and an alternative aerator nozzle packed separately which can be fitted at high pressures to reduce Splashing.

Installation

Pillar Taps

- Remove backnut from tap tail.
- Fit tap through ware ensuring anti-rotational washer is trapped in position Between tap base and ware, replace backnut and tighten.
- Thoroughly flush pipework and connect to tap. Hot should be on the left and cold On the right when viewing pipework from the front.

Mon Sink / Side Action Mono Sink Mixer

- i) Screw inlet tails into body and tighten up ensuring washer seal is firmly in place to prevent any leaks.
- Please note: For standard mono sink go to point (iv)
- ii) For Side Action Mono Sink Mixer – Locate the handle from the box and remove the indice (plastic bung) from under the lever part of the handle. Locate the handle onto the square spindle of the exposed cartridge, then using the Allen Key provided screw the grub screw (packaged with the clamping kit) into the handle and tighten onto the cartridge.
- Please note: The handle should be positioned pointing towards you (when viewing the tap from the front) for its natural off position!
- iii) Once in position relocate the indice (plastic bung) into the hole under the lever, ensuring the red and blue printed on the indice is the correct way around.
 - iv) Screw in the clamping stud into the body and position rubber seal under the base of the mixer, then position the mixer into the ware in desired position ensuring lever movement is not obstructed.
- Please note: Ensure free movement of spout is adequate before clamping in position.
- v) To tighten the mixer to the ware, Firstly, place clamping plate rubber then the steel clamping Plate onto the stud, then secure by screwing tight the clamping nut. Re check the mixer position above the ware and ensure the spout still rotates freely.
 - vii) Connect inlets to supplies, (Fit non return valves if system is imbalanced)

To fit handles (Where applicable)

- To fit handle place snap fit connector
 (A) onto spline of headwork
 (B) and screw down firmly using screw provided
 (C). Place handle
 (D) over connector and push firmly until it snaps home.

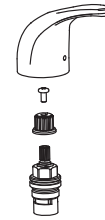
**Bath Filler/ Bath Shower Mixer**

- i) Remove backnuts from inlet tails and fit tails through tap holes of bath ensuring base rubber is trapped between bath and fitting. Replace and tighten backnuts from beneath bath.
- ii) Thoroughly flush pipework and connect tap to the supplies ensuring hot is on the left and cold on the right when viewing the mixer from the front.
- iii) Fit shower hose and kit to the bath mixer.
- iv) For all brassware supplied without handles, see separate handles instructions.
- v) For servicing or handle realignment the brassware supplied will be:
 - Snap on (push on –pull off)
 - Fixed with a locating screw
 - Fixed handle and spindle
- vi) Fixing the kit to Bath Shower mixers
 - Mark the holes and drill with 6mm bore
 - Insert plugs and fasten screw
 - Click on the shell and connect the shower hose

Monobloc Basin Mixer

- Pegler Basin mixers are supplied with separate inlet tails. M12 flexible tails 12" long
- i) screw inlet tails into body and tighten up ensuring 'O' ring seal is firmly in place and leak proof, unless pre fitted securing studs to be fitted and tighten
 - ii) Locate seal under flange (or base of monobloc).
 - iii) Place fittings through hole in ware. Place washer over inlet tails and position on underside of ware. Place clamping plate on threaded stud/s ensuring that stud is positioned in the slot in the clamping plate and that the inlet tails are positioned in the cut out. Place fixing nut onto threaded studs and loosely tighten firmly up the base of Ware / worktop.
 - iv) Insert click waste
 - v) Ensure pipework is thoroughly flushed to remove debris before connecting to the fitting, Connect to the water supplies.
 - i) Ensure that the O ring seals are fitted correctly in their grooves screw the tails into the body.

Care & Maintenance

To maintain the surface finishes, simply wipe occasionally with a mild detergent on a soft damp cloth. Dry using a soft cloth, never use abrasive cleansers or chemical household cleaners, and avoid contact with concentrated bleach. Pegler products are manufactured to the highest of standards and should require little or no maintenance. In the unlikely event of any spare part requirements, please contact your nearest stockist or the Pegler Sales Office, St Catherine' s Avenue, Doncaster. DN4 8DF, Telephone 01302 368581.

To maintain the surface finishes, simply wipe occasionally with a mild detergent on soft damp cloth. Dry using soft cloth, never use abrasive cleaners or chemical household cleaners, avoid contact with concentrated bleach.

Pegler products are manufactured to the highest standards and should require little or no maintenance. In the unlikely event of any spare part requirements, please visit our website: www.pegler.co.uk, contact you' re nearest stockist or the Pegler Technical Office on telephone 0870 1200285

Customer Reference Data

Date of Purchase.....

Supplier.....

Supplier Tel. No.....

Model Type.....

Serial No.....

Installer.....

Installer Contact Details.....

**Your Guide to the installation, Care and maintenance of**

Izzi

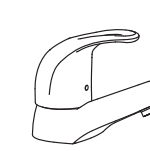

1/2"Basin Taps
 3/4"Basin Taps

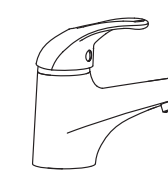

SL Mini Mono Basin

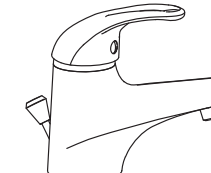

SL Mono Basin

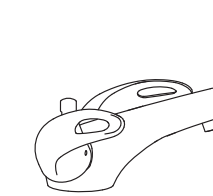

DC Mono Basin

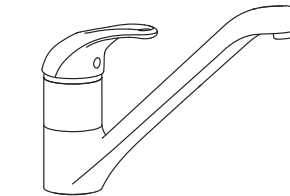

Mono Sink Mixer



Bath Filler

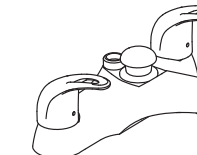

Deck Bath Shower Mixer

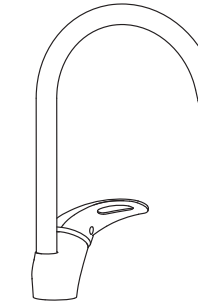

S/A Mono Sink Mixer



Pegler Yorkshire

Pegler Limited, St Catherine' s Avenue, Doncaster DN4 8DF
 Telephone 01302 560560, Fax 01302 560109



Pegler Limited, St Catherine' s Avenue, Doncaster DN4 8DF
 Telephone 01302 560560, Fax 01302 560109