

3. Fit shower hose and kit to the bath mixer.
4. For all brassware supplied without handles, see separate handles instructions.
5. For servicing or handle realignment the brassware supplied will be:
 - Fixed handle and spindle with a side grub screw and screw down cover.
6. Fixing the kit to Bath Shower mixers
 - Mark the holes and drill with 6mm bore
 - Insert plugs and fasten screw
 - Click on the shell and connect the shower hose

3 HOLE DECK MOUNTED BASIN AND BATH INSTALLATION

1. Both are supplied with Flexi tails for connection from the side valves to the centre spout. These have been designed to suit 3 hole basins installations with 200mm centres from the outer tap holes. The inlet connections are 15mm compression.
2. The bath filler has a spout which is removable to avoid damage during installation / tiling / plastering etc. It is secured onto the shank by means of a grub screw in the rear of the shank. The shank and the side valves can be fitted first and the spout positioned later if required.
3. Screw inlet tails into basin body and tighten up ensuring 'O' ring seal is firmly in place and leak proof.
4. On bath lower shank through hole in ware and screw on 'T' piece ensuring seal is in place. Also ensure 'O' ring is in place below shank collar.
 - Screw inlet tails into 'T' piece
 - Reposition spout and tighten using grub screw at the rear of the spout.
5. For the basin place fitting through hole in ware ensuring that the sealing washer is trapped between base of the spout and top of the basin / worktop. Place washer over inlet tail and tighten firmly up to the base of ware / worktop.
Note : If grips are used to hold the shank above the basin take care not to damage "O" ring seal or groove for grub screw.
6. Identify hot and cold side valves by coloured marking Red = Hot Blue = Cold. Hot should be on the left, cold on the right when viewed from the front.

7. Ensure backnut is fitted to the side valve and screwed down to the lowest point, fit the sealing washer onto the top of the backnut. Place sidevalve up through the ware and fit washer followed by the sidevalve cover and loosely tighten down. Then locate the handle loosely screw up the flange to the handle base.
8. Tighten sidevalve using the backnut under the basin.
9. Connect the flexi hose from the shank to the outlet of the sidevalve (ensure that the direction of flow is correct)
10. Route the pipe work to the inlet of the sidevalves. Ensure pipework is thoroughly flushed to remove debris before connecting to the basin filler and check for water leakage.
11. For servicing or handle realignment the brassware supplied will be fixed with a side grub screw and screw down cover.

3 HOLE WALL MOUNTED BASIN INSTALLATION

1. The basin filler is supplied with Flexi tails for connection from the side valves to the centre spout. These have been designed to suit 3 hole basin installations with 200mm to 600mm centres. The inlet connections are 15mm compression.
2. Determine position of the basin filler on the wall above the basin. Create access door to give access to the required basin filler position and route supply pipework to the basin mixer position terminating in female iron connections.
3. Note : Pipework should be firmly clamped at point where the basin filler mixer is to be installed to prevent any movement.
4. Drill mounting holes at suitable centres - 32 mm dia for spout, 38 mm for side valves.
5. Remove handles and flanges from side valves (if pre-fitted)
6. Insert spout through wall, use large washer and backnut to clamp in place ensuring sealing washer is fixed in place.
7. Connect Tee piece to plain end of spout, tightening securely using compression joint. Side valves should be clamped to a suitable support or firmly supported by the pipe work, ensuring that the chrome sleeves will be in a suitable position relative to the wall surface to enable fitting of the loose flanges. The side valves should be

- identified by the coloured marking Red = Hot and Blue = Cold. Hot should be on the left hand side and Cold on the right hand side when viewed from the front.
8. Connect the flexi hoses to the outlet of the side valves(ensure that the direction of flow is correct) and then connect to the centre body
 9. Route the pipe work to the inlets of the side valves. Ensure pipework is thoroughly flushed to remove debris before connecting to basin filler and check for water leakage.
 10. Make good the wall surface.
 11. Fit flanges and handles to side valves to complete installation.
 12. For servicing or handle realignment the brassware supplied will be fixed with a side grub screw and screw down cover.

CARE & MAINTENANCE

To maintain the surface finishes, simply wipe occasionally with a mild detergent on soft damp cloth. Dry using soft cloth, never use abrasive cleaners or chemical household cleaners, avoid contact with concentrated bleach. Xia products are manufactured to the highest standards and should require little or no maintenance. In the unlikely event of any spare part requirements, please contact your nearest stockist or the Pegler Sales Office,

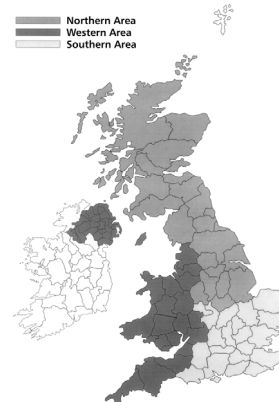

St. Catherine's Avenue, Doncaster, DN4 8DF, telephone; 01302 560560.

10 YEAR GUARANTEE

Pegler Taps and Mixers are guaranteed for 10 years from the date of purchase.

Your Guide to the installation,
care and maintenance of

Xia

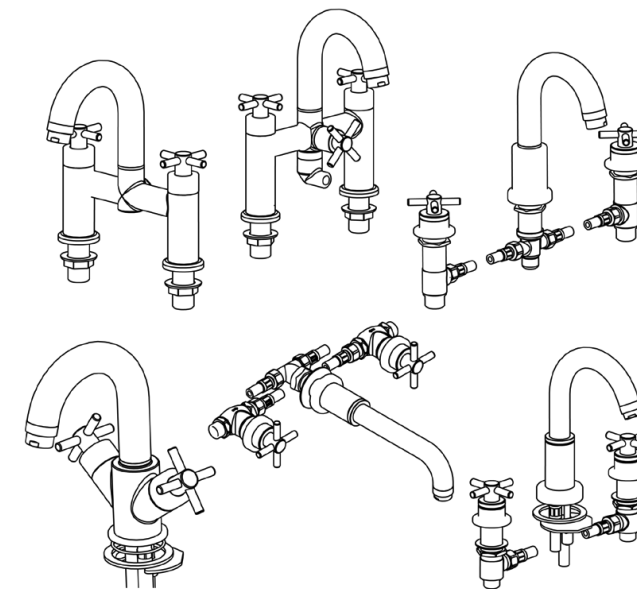

francis
pedler



Pegler Limited, St. Catherine's Avenue, Doncaster. DN4 8DF
Telephone: 01302 560560 Fax: 01302 367661

WATER REGULATIONS REQUIREMENTS

It is important to ensure that the water supplies to your taps and mixers are connected in accordance with the water regulations (WRAS) requirements and good plumbing practice.

It is Pegler recommendation and good plumbing practice that the supplies of hot and cold water to the bath mixer should be at equal (balanced) pressures in order to provide a consistent flow. Supplies should be from a common source, either mains or tank fed. If supplies are not equal pressures then non return valves (801 check valves), (not supplied) should be fitted in each inlet supply line.

The outlet of the fitting must be at least 25mm above the spill over level of the bath.

It is recommended that in all new and refurbishment installations a thermostatic mixing valve should be installed on the hot inlet supply. The thermostatic mixing valve is designed to prevent scolding when using the hot water supply.

WATER SUPPLY PRESSURE

Pegler fittings have been designed to function under the following conditions.

- Minimum supply pressure 0.1 bar
- Maximum supply pressure 6 bar

Should excessive flow be experienced, then it may be necessary to install a Pressure reducing valve (not supplied).

It is our recommendation and good plumbing practice that a service valve (fig.806) should be installed in the inlet supply line.

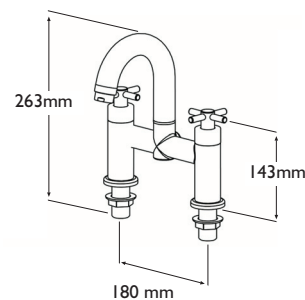

4K8015 XIA CP PILLAR PATTERN BATH FILLER

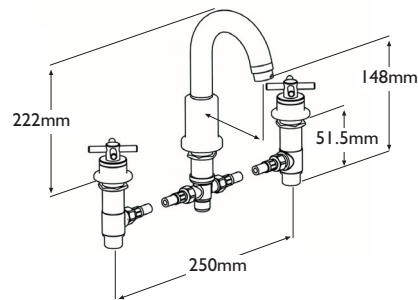

4K8017 XIA CP 3 HOLE DECK BATH MIXER

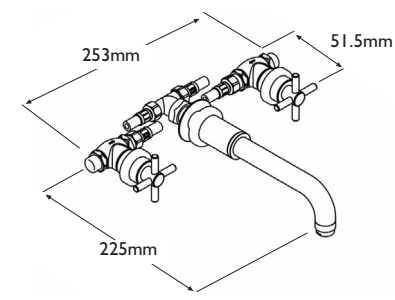

4K8018 XIA CP 3 HOLE WALL MOUNTED BASIN MIXER

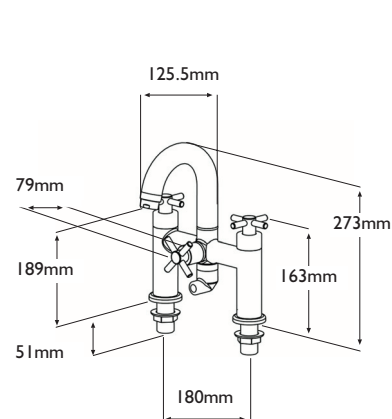

4K8016 XIA CP PILLAR PATTERN BATH/SHOWER MIXER CW KIT

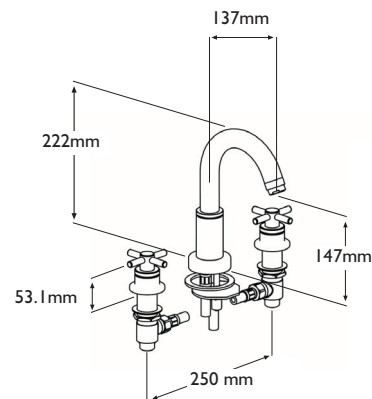

4K8017 XIA CP 3 HOLE DECK BASIN MIXER

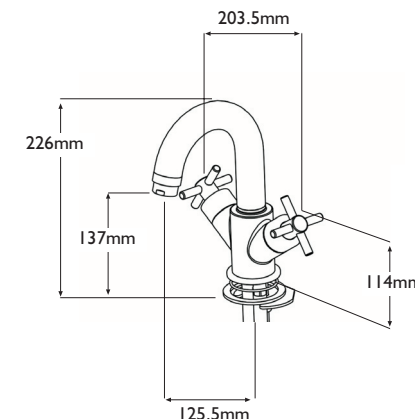

4K8014 XIA CP MONOBLOC BATH FILLER

PRE-INSTALLATION CHECKS

1. Ensure that there is sufficient space to install the product without it hampering its operation. Ensure that when fitting the bath product that the product will not foul on the overflow. When fitting in a corner position make sure there is sufficient clearance for the use of the handles
2. 2. Ensure that the outlet will protrude sufficiently into the bath and will clear any obstructions
3. When installing the product the hot inlet should be on the left hand side and the cold on the right hand side when viewed from the front.

MONOBLOC BATH FILLER

Pegler Bath mixers are supplied with separate inlet tails.

1. screw inlet tails into body and tighten up ensuring 'O' ring seal is firmly in place and leak proof, unless pre fitted securing studs to be fitted and tighten
2. Locate seal under flange (or base of monobloc).
3. Place fittings through hole in ware. Place washer over inlet tails and position on underside of ware. Place clamping plate on threaded stud/s ensuring that stud is positioned in the slot in the clamping plate and that the inlet tails are positioned in the cut out. Place fixing nut onto threaded studs and loosely tighten firmly up the base of ware / worktop.
4. Ensure pipework is thoroughly flushed to remove debris before connecting to the fitting. Connect to the water supplies.

DECK BATH FILLER/ BATH SHOWER MIXER

1. Remove backnut from tail and fit tails through taps holes of bath ensuring base rubber is trapped between bath and fitting.
2. After thoroughly flushing, connect pipe work to the inlet supplies