

Pivot Door

Instruction Manual

EF



IMPORTANT INFORMATION

Be aware toughened glass can shatter if not handled correctly. It should not be subjected to any sharp impact and it is essential to protect the glass by resting it on a soft protective surface during installation such as cardboard or carpeting. It is recommended to wear PPE at all times during installation.

**UK
CA**



PRE-INSTALLATION CHECKS

1. Check you have the correct product. Please look at the labels on the side of the product packaging.
2. Check all the product components are in the box and the fixing kits.
3. Unpack your product and handle it with care.
4. Please check the product for defects or damage, once the installation has commenced we cannot accept responsibility for any defects or damage.
5. Please take time to read these instructions prior to installing your product.
6. Before you commence any drilling check there are no hidden electrical cables and/or water pipes.
7. No attempt should be made to re-work the toughened safety glass.
8. The installation of the product should be performed by two persons.
9. It is strongly recommended that the walls the product is going to be installed on are vertical.
10. It is strongly recommended the product is fitted on a tiled surface or similar waterproof surface.
11. It is strongly recommended the walls are tiled and grouted before the product is installed.
12. If the walls and/or the tray are not level you will not achieve maximum adjustment of the product.
13. Pictures used are for illustration purposes only, product designs may alter slightly as a result of continuing product development.
14. We do not stipulate where the European Standard Kite Mark should be positioned on the glass when being factory assembled.
15. Please note that some natural misting may occur when you remove this product from its packaging, due to the addition of the glass protection pre-coating. If this does occur this can easily be removed with a soft, dry cloth.

Component Check List: Supplied

Description	Quantity
Wall Profiles	2
Pivot Door	1
Top Caps	2
Pivot Side Vertical Seal	1
Angled Door Magnet	1
Bottom Seal (Long)	1
Bottom Seal (Short)	1
Handle	1

Equipment Check List: Not Supplied

Description
4.5mm drill bit (if Installation Procedure B is required)
Electric / Battery Drill
6mm Masonry Drill Bit
Silicone Sealant Gun
Bathroom Sealant
Screwdriver
Spirit Level
Tape Measure
Pencil
Wall Plugs (for Plasterboard if necessary)

Fixing Kit Components

Description	Quantity
2.5mm Drill Bit	1
Wall Plugs (for brick and block only)	6
40mm screws	6
Coloured Caps and Bases	12
9mm screws	6
Branding Badge (where applicable)	1

CONSUMER GUARANTEE

Please make sure the purchaser/end user completes and returns the guarantee card which is enclosed with this product. Failure to validate the Guarantee will mean only the 1 Year Statutory Guarantee will apply.

Step 1 - Preparation

NOTE: The Pivot Door is designed to fit into an alcove between two tiled walls (as shown below) or with a return panel.

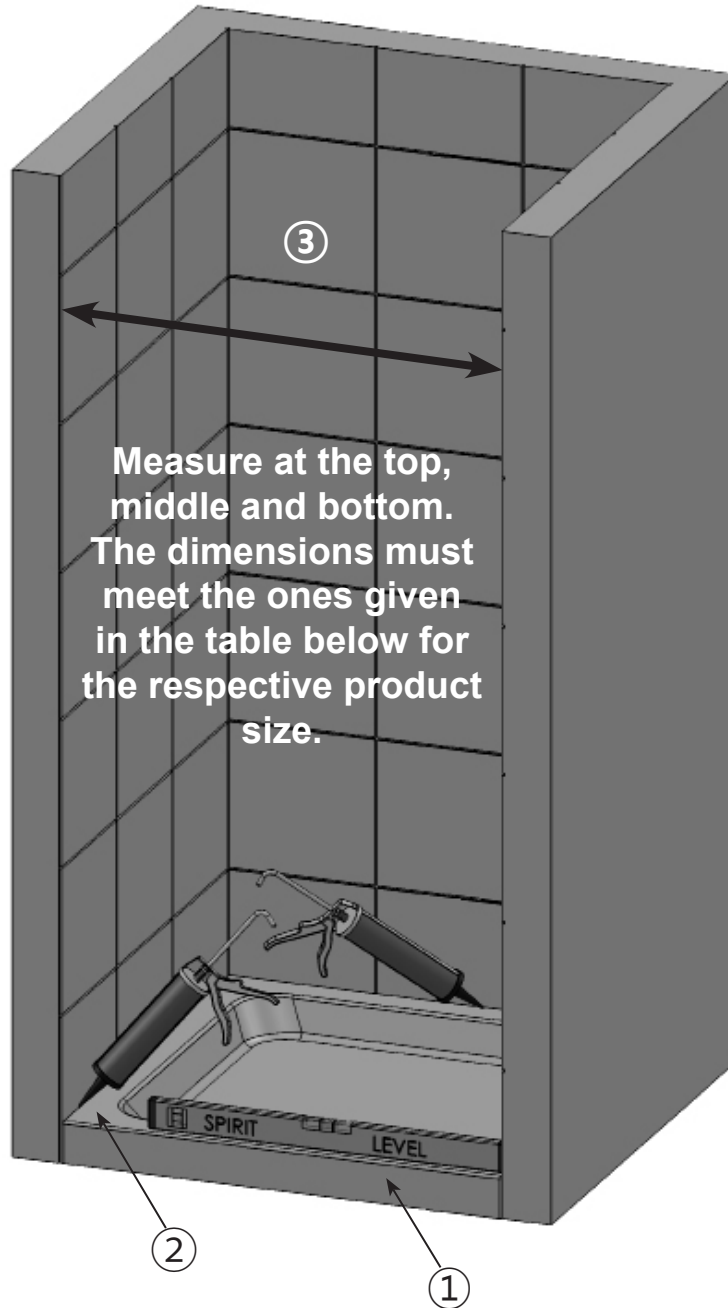

Product Code	Minimum Alcove Size	Maximum Alcove Size
EF76	715mm	765mm
EF	755mm	805mm
EF9	855mm	905mm

1. Ensure the tray is completely level and check for any movement by standing in it - correct as necessary.
 - **Please ensure that the tray is installed as per the manufacturers instructions.**
2. Seal the tray fully along the tiled walls prior to installation with a bathroom sealant (not supplied).
 - **Prior to fitting the enclosure and when the sealant has fully cured, spray the shower handset over the joints and check for any leaks.**
3. **IMPORTANT:** Prior to installing/attempting to fit the Pivot Door into an alcove measure the opening at the top, middle and bottom after all tiling and grouting has been done. Check this against the dimensions given in the table shown above to see if your alcove meets the criteria.
 - **Check the plumbing for leaks.**
 - **Do not plasterboard over the tray.**
 - **Do not grout the tiles when the enclosure has been fitted as the grout may discolour the aluminium.**

Step 2 - Fitting 1st Wall Profile (Alcove)

Note: If this product isn't being fitted in an Alcove but with a return panel then both wall profiles can be fitted now following the procedures below.

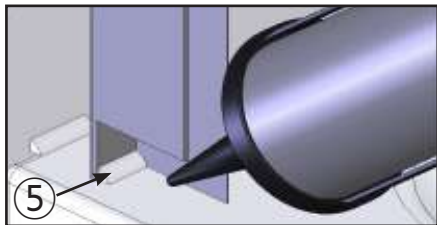
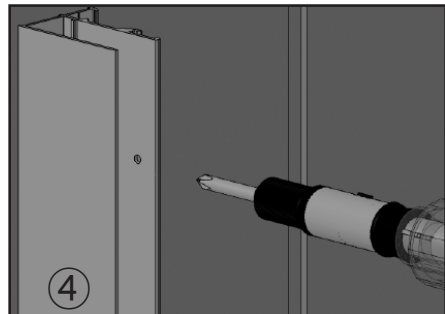
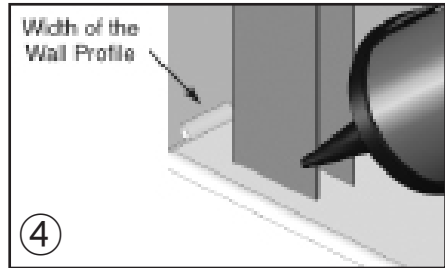
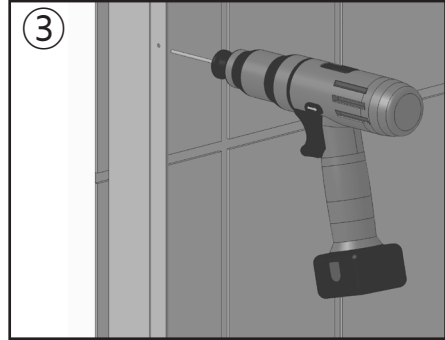
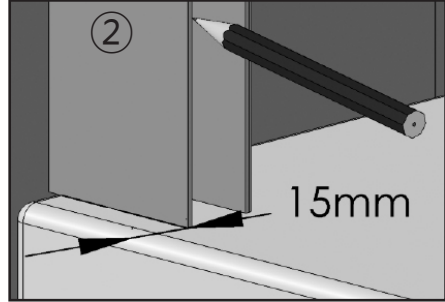
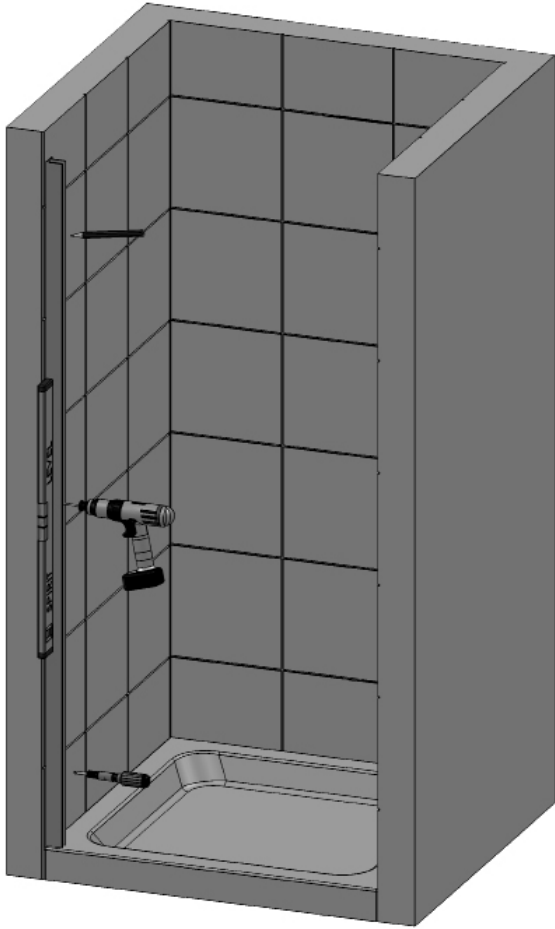

1. Decide which side of the alcove the fixed/panel side of the enclosure is to be fitted. Drill three 4.5mm holes into the U-Channel on the wall profile, approximately 100mm from each end and the last one positioned in the centre.
2. Place the wall profile 15mm in from the outside of the tray, the lip section of the wall profile must face inward towards the shower. Make sure the wall profile is completely vertical using a spirit level and mark the wall through the drill holes with a pencil.
3. Drill the wall with a 6mm Masonry Drill Bit (not supplied) where the Wall Profile is to be positioned. Fit the Wall Plugs supplied (if going in to a brick or block wall). If going into a plasterboard wall you will need to purchase appropriate wall fixings. Wipe clear all debris from the Tray before referring to the next stage.
4. Where the Wall Profile is to be positioned on the Tray, place a bead of Bathroom Sealant (not supplied) the width of the Wall Profile along the tiled wall. Screw the Wall Profile to the wall with 40mm Screws (supplied). Do not over tighten the screws into the Wall Profiles as this will misshape the Wall Profile. Ensure the Wall Profile stays completely vertical throughout this procedure using a Spirit Level.
 - **Failure to carry out this procedure correctly can result in serious water damage and is not covered by the Guarantee.**
 - **No sealant should be present between the Wall Profiles and the tiled walls vertically prior to screw fixing.**
5. Seal the gap on the inside between the Tray and Wall Profile with a Bathroom Sealant (not supplied).
 - **Failure to carry out this procedure correctly can result in serious water damage and is not covered by the Guarantee.**

Step 3 - Preparing the 2nd Wall Profile (Alcove)

NOTE: This Wall Profile is to be fitted to the side of the alcove where the door opening is to be.

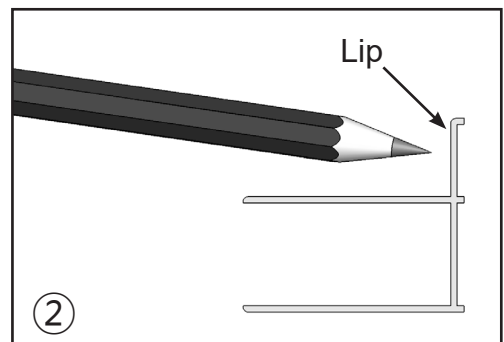
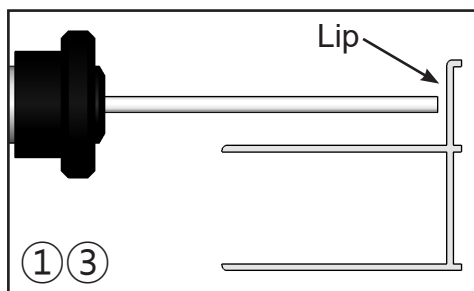
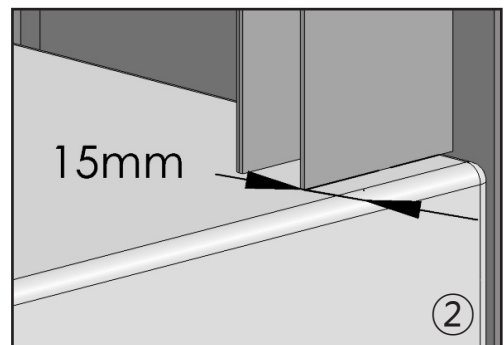
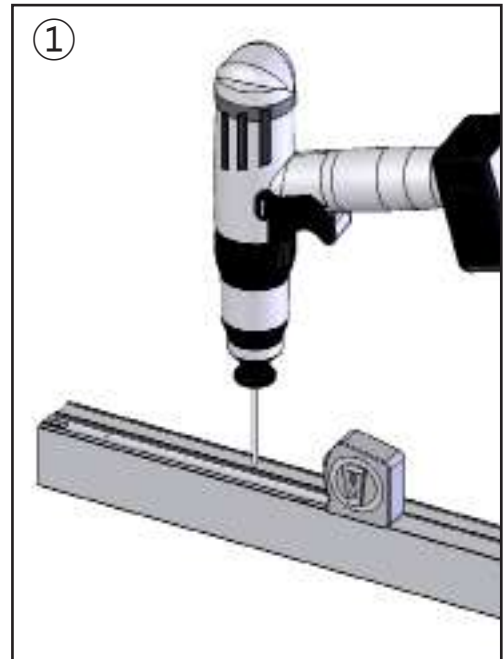
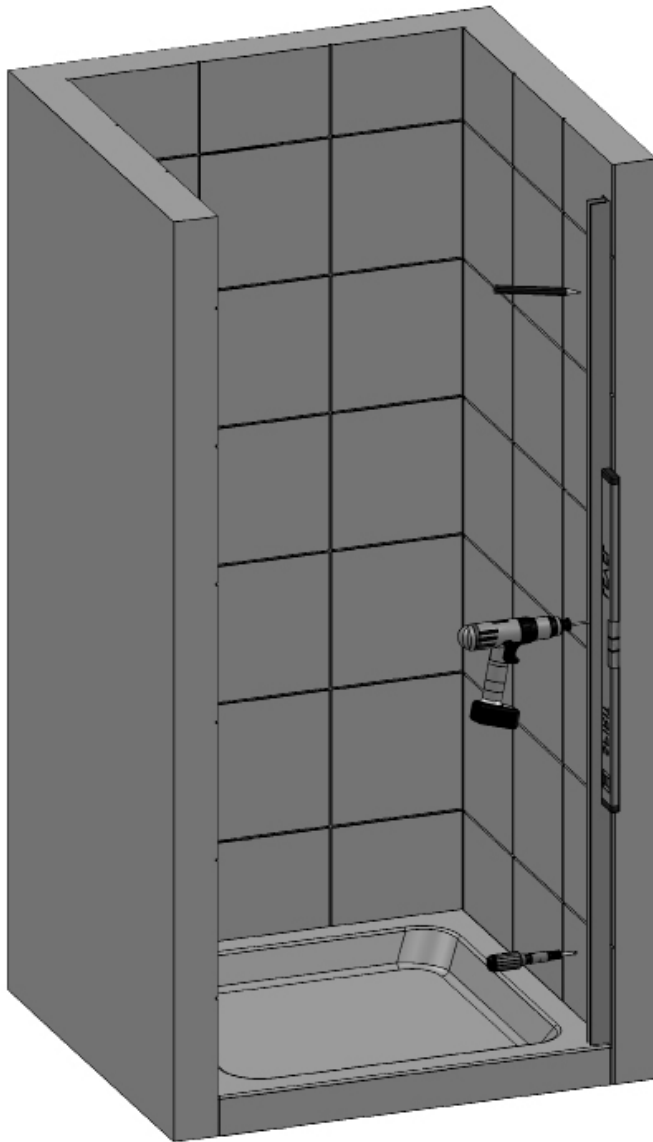

1. Take the remaining wall profile and drill three 4.5mm holes into the lip, approximately 100mm from each end and the last one positioned in the centre.
 - **Drill the holes through the face that goes to the wall - deburr all holes.**
2. Place the wall profile 15mm in from the outside of the tray so that it matches the 1st wall profile, the lip section of the wall profile must face inward towards the shower. Make sure the wall profile is completely vertical using a spirit level and mark the wall through the slots with a pencil.
3. Drill the wall with a 6mm Masonry Drill Bit (not supplied) where the Wall Profile is to be positioned. Fit the Wall Plugs supplied (if going in to a brick or block wall). If going into a plasterboard wall you will need to purchase appropriate wall fixings.
 - **IMPORTANT: Do not fit the wall profile at this stage, it will be fitted to the wall later in the installation.**

Step 4 - Installing the Door, Handle and Fixing the 2nd Wall Profile (Alcove)

NOTE: The stages below will require 2 people to carry them out. On stage 5 when lifting the Door Assembly to seal the inside of the 2nd wall profile place a wooden chock or similar between the enclosure and the top of the tray to prevent it from falling and causing injury (carefully remove when done).

IMPORTANT: Remove the Red Transit Blocks before installing the door (see below).

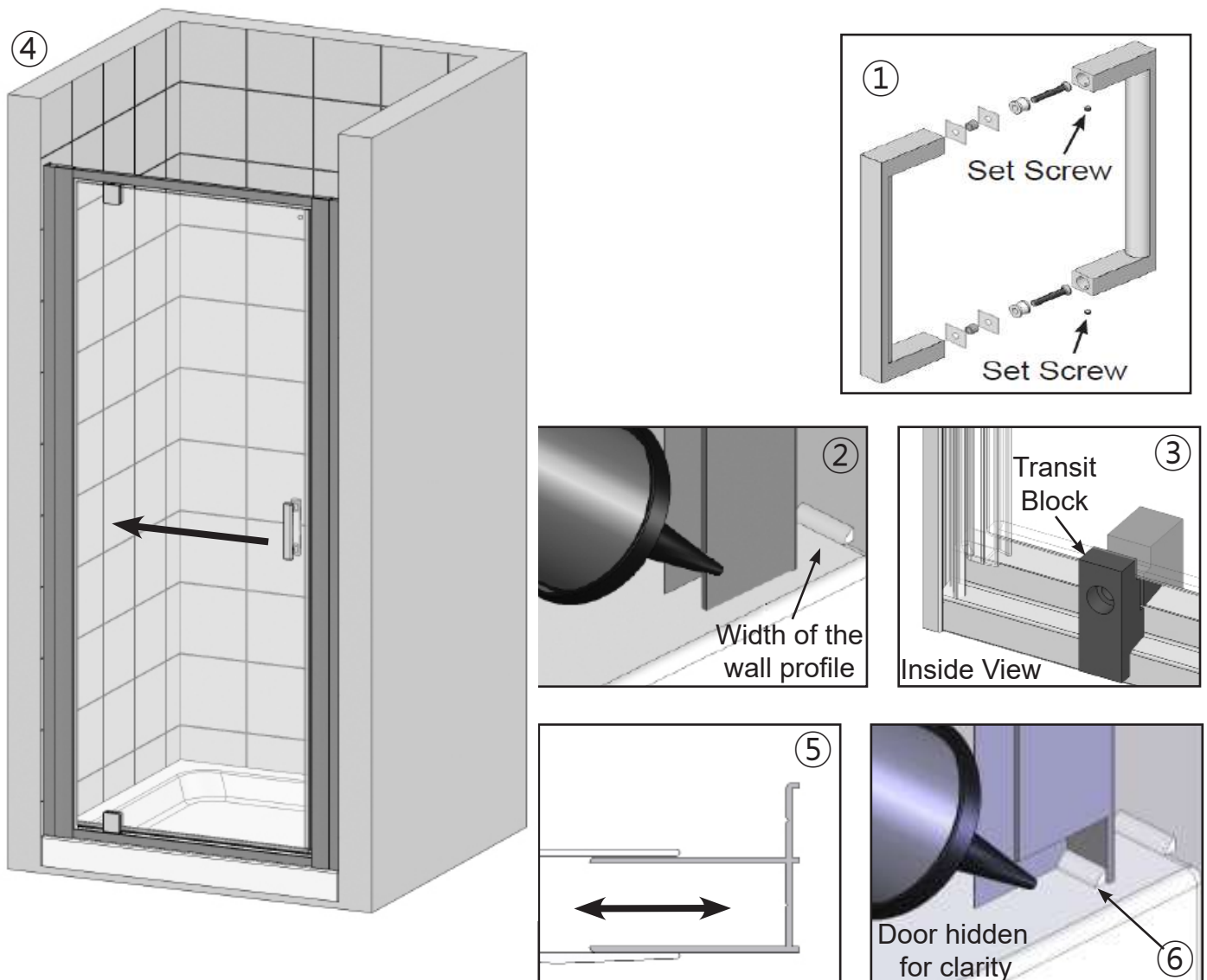

1. Remove the handles from the packaging, using the Allen Keys (supplied) remove the screws and split the handle assemblies. Fit onto the door glass ensuring the Set Screws are on the inside of the enclosure.
2. Prior to fixing the 2nd wall profile apply a bead of Bathroom Sealant (not supplied) the width of the wall profile where it meets the tiled wall and tray at the bottom.
3. Remove the Red Transit Blocks from the top and bottom of the Door by removing the screws. Take care after removal and prevent the door from twisting and opening.
 - **Note: Please retain the Red Transit Blocks and screws in case the Door has to be moved or refitted.**
4. Place the Door over the already fitted (1st) wall profile which you decided in Step 2 and push fully together.
 - **NOTE: The Wall Profile and Door Vertical sit over each other.**
5. Place the 2nd Wall Profile over the other end of the Door as far as it will go and then push it back to the wall. Fit the screw bases to the 40mm screws and screw fix through the lip and fit the coloured cover caps.
6. Carefully lift the Door Assembly and seal the gap on the inside between the Tray and Wall Profile with a Bathroom Sealant (not supplied).
 - **IMPORTANT: Failure to carry out Stages 2 and 6 can result in serious water damage and is not covered under the terms of the guarantee.**
 - **Ensure that the pivot end of the enclosure is fitted to your 1st wall profile.**
 - **The wall profiles must be completely vertical (the bubble on the Spirit Level must be in the centre of the 2 lines).**

Step 5 - Fixing the Door to the Wall Profiles

NOTE: The stages below will require 2 people to carry them out.

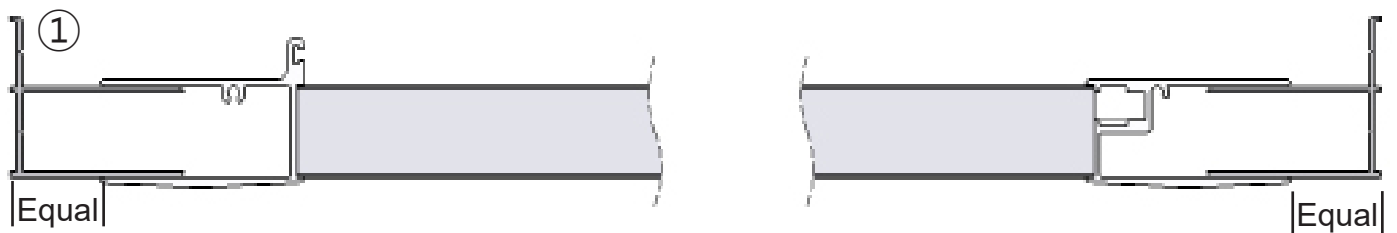
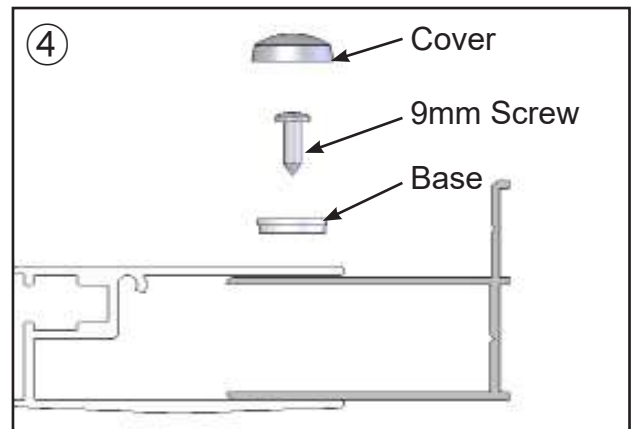
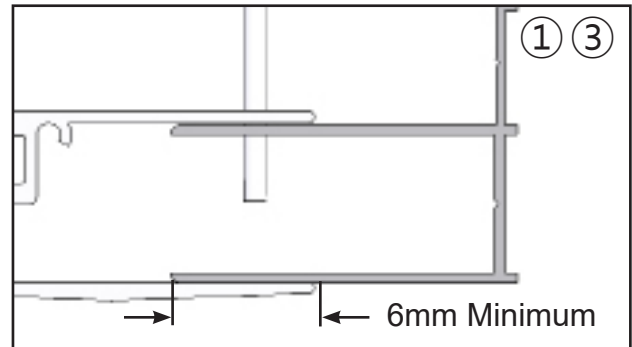
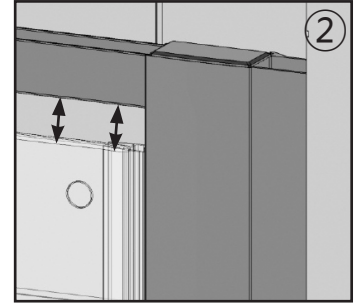
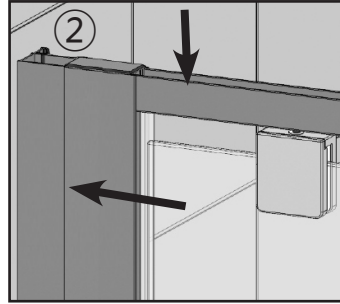
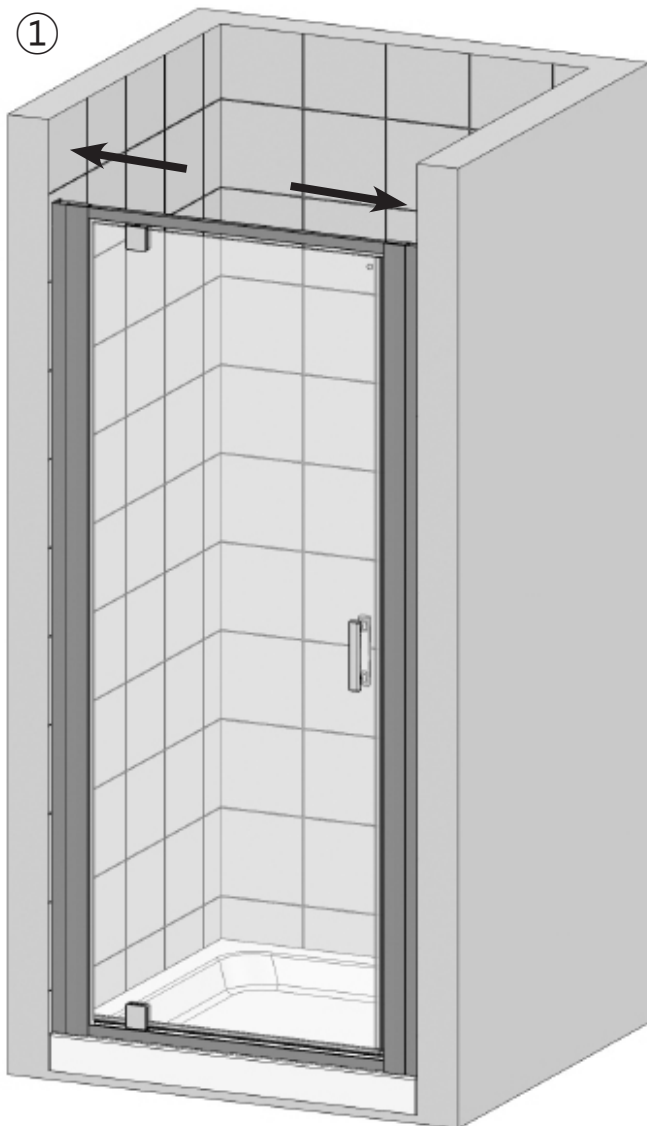

1. Centralise the door between the wall profiles, there must be a minimum of 10mm for fixing.
2. Adjust the door within its own main frame to ensure the gap between the top and bottom of the door and the horizontal main frame is parallel. To achieve this adjustment push the main vertical door frame from the top further over the wall profile following the arrows, this will ensure the door lifts up away from the bottom of the horizontal main frame.
 - **IMPORTANT: It is critical that the door opens and closes correctly prior to drilling.**
3. Drill 3 holes in each wall profile approximately 100mm from the top and bottom and one in the centre into the Door vertical frame with the 2.5mm drill supplied.
 - **Ensure the door is completely vertical (the bubble on the Spirit Level must be in the centre of the 2 lines).**
4. Place the bases onto the 9mm screws and screw fix the door to the wall profiles, push on the coloured caps.

Step 6 - Fitting the Seals

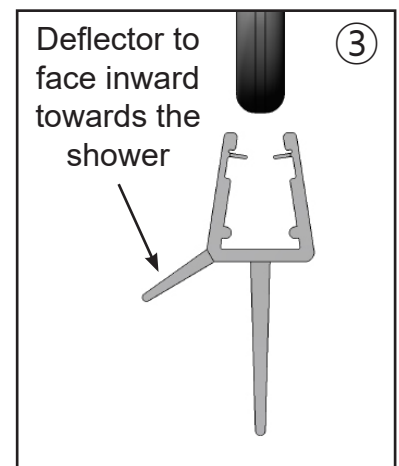
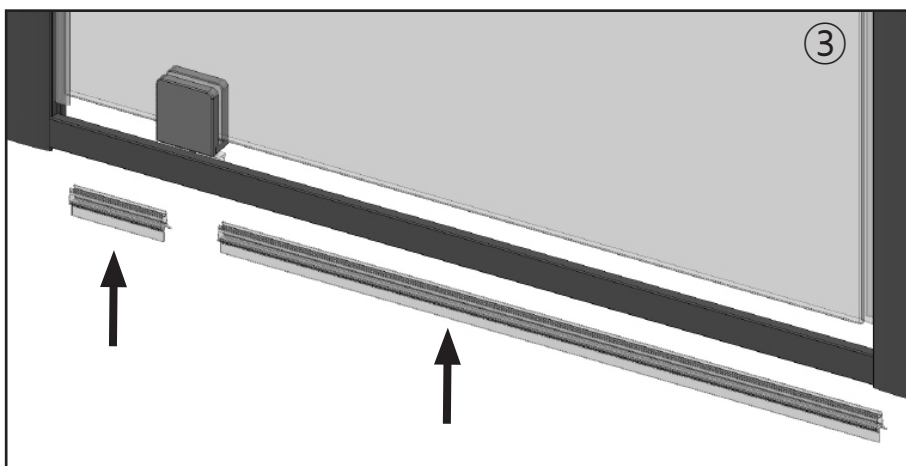
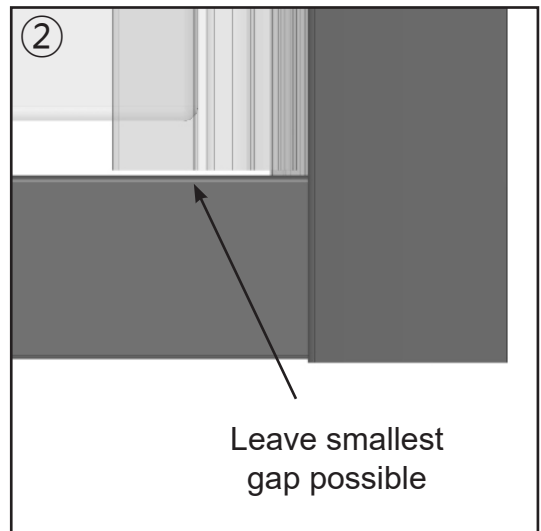
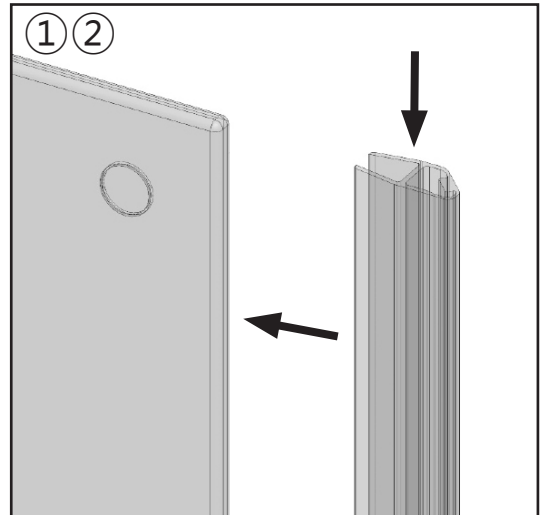
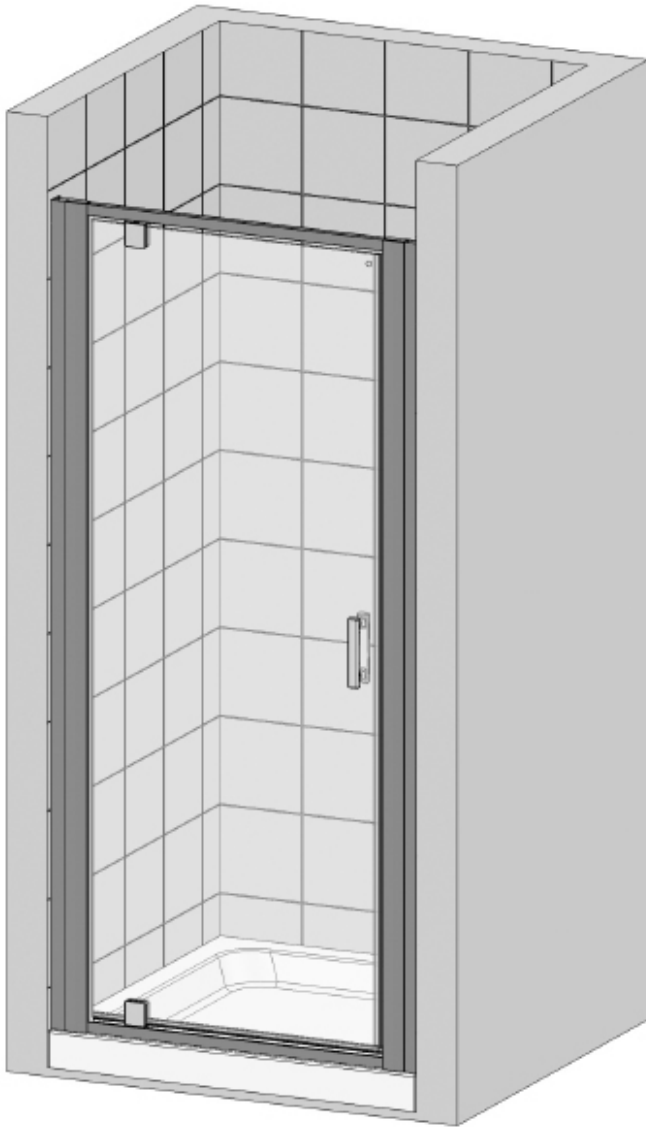

1. Fit the angled magnet on the door at the side where the handle is, taking into account its shape and how it will meet the magnet that is already fitted to the door frame.
2. Push the angled magnet down towards the bottom horizontal rail leaving the smallest gap possible (this is to maintain that the product is water tight but the door can still be opened and closed).
3. Fit the bottom seals onto the bottom of the glass between the pivot assembly and the edges of the glass (cut down as required). Ensure that the deflector is facing inward towards the shower.

Step 7 - Sealing

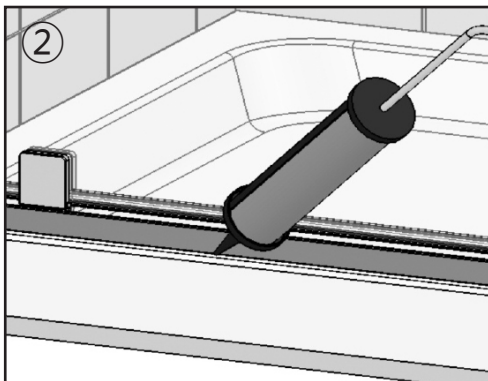
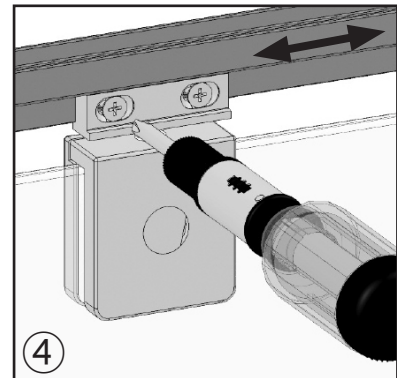
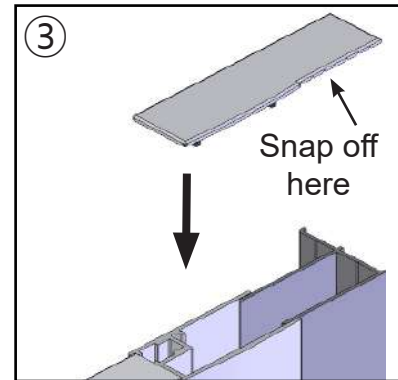
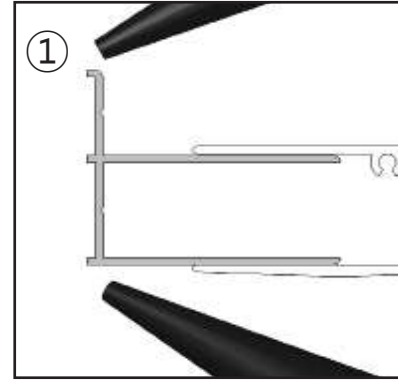
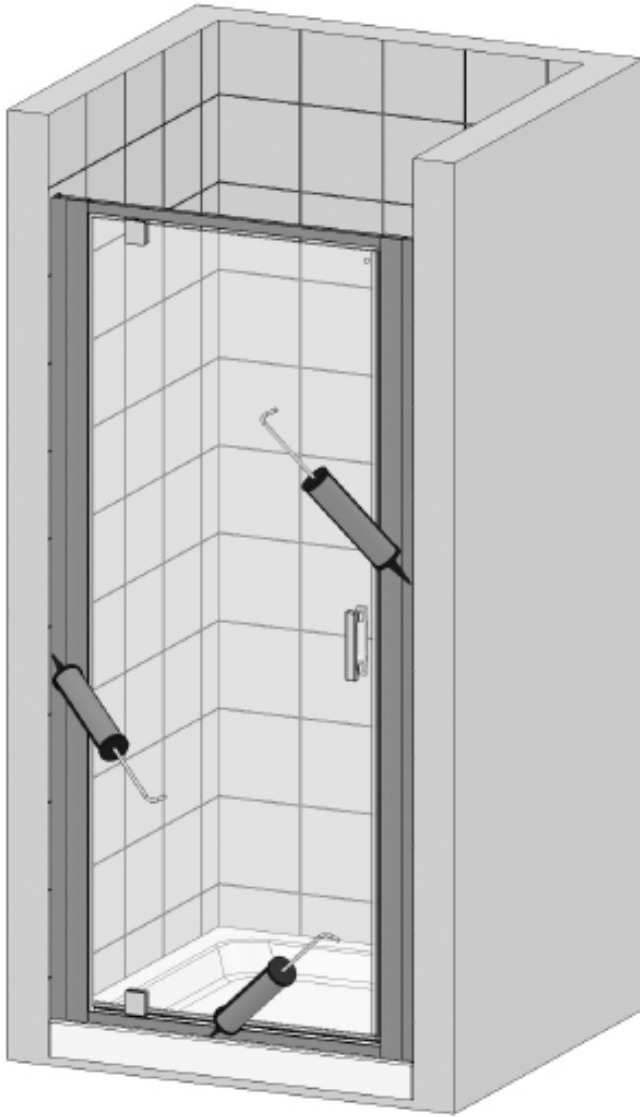

1. Seal the wall profile vertically, both internally and externally where they meet the tiles.
2. Seal the base of the enclosure to the top of the tray from wall to wall on the outside only.
 - **IMPORTANT: Failure to carry out stages 1 and 2 may result in serious water damage and is not covered under the terms of the guarantee.**
 - **DO NOT seal the base of the product to the inside, failure to comply may result in the product leaking.**
 - **Allow 24 hours for the sealant to fully cure prior to using the shower.**
3. The Top Caps have grooves and can be shortened by snapping off at these points (adding a small amount of sealant will help keep them in place).
4. If required, slight adjustment is possible in the door pivot assemblies to ensure the glass door is parallel to the horizontal main frame. With a screwdriver loosen the screws by about 2 turns and adjust the door pivot assemblies so that the glass is parallel and retighten the screws.
 - **Make sure the magnets on the door and frame locate onto each other down the full length of the door, the angled door magnet can be moved on the glass to achieve this.**
5. Place the branding badge in a prominent position on a none moving part of aluminium.

Spare Parts

If you need to replace any damaged parts please see illustration below for parts list then call Customer Relations on 01325 328033

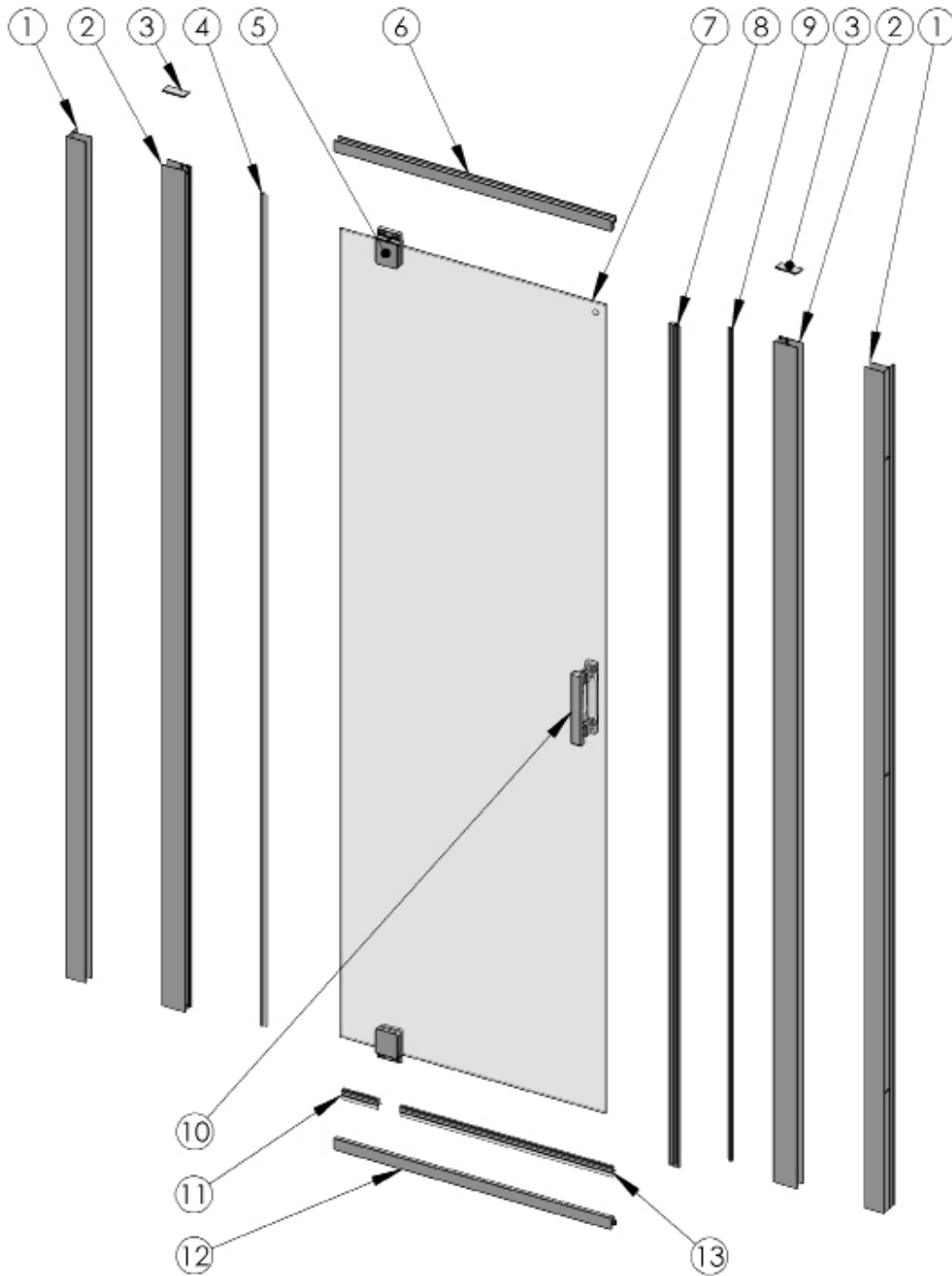

Part No.	Description	Q'ty	Part No.	Description	Q'ty	Part No.	Description	Q'ty
1	Wall Profiles	2	11	Bottom Seal (Short)	1	21		
2	Vertical Main Frame	2	12	Horizontal Mainframe (R-H)	1	22		
3	Top Cap	2	13	Bottom Seal (Long)	1	23		
4	Vertical Seal (Pivot Side)	1	14			24		
5	Door Pivot Assembly	2	15			25		
6	Horizontal Mainframe (L-H)	1	16					
7	Door Glass	1	17					
8	Angled Door Magnet	1	18					
9	Vertical Frame Magnet	1	19					
10	Handle	1	20					

TROUBLE SHOOTING GUIDE

Problem	Solution
Leaking	<ol style="list-style-type: none">1. Check the tray is sealed correctly along the tiled walls prior to installation.2. Check that the inside gap between the Tray and Wall profiles has been sealed correctly.3. Check the base of the enclosure is sealed on the outside only.4. Check that a bead of sealant the width of the wall profile has been applied.5. Check the wall profiles on the tiled walls are sealed both vertically inside and outside.6. Check all the seals have been cut and positioned correctly. <p>Important: This enclosure should be water tested conforming to BS EN 14428</p>
Enclosure Alignment on the Tray or Floor	<ol style="list-style-type: none">1. Check the enclosure has been fitted onto a tiled wall or similar sealed surface.2. Check that the wall profiles are fitted 15mm in from the front of the tray.3. Check the wall profiles are completely vertical.
Door not operating / closing correctly	<ol style="list-style-type: none">1. Check the tray is completely level, this could have an effect on the positioning of the door when adjusted. You may not have enough adjustment within the wall profile due to compensating for an out of level tray.2. Check the wall profiles are completely vertical.3. Are the magnets on the glass door and frame locate to one another all the way down.4. If the door doesn't fully close properly or springs open, you will need to check the wall profiles with a spirit level. One of the wall profiles will be moving in the opposite direction to the other, realign the profiles so that they are both completely vertical.
Glass Door Alignment	<ol style="list-style-type: none">1. Check the tray is completely level, this could have an effect on the positioning of the door when adjusted and you may not have enough adjustment.2. Check the wall profiles are completely vertical.3. The glass is not parallel to the mainframe (i.e. unequal gap). Adjust the door on the pivot side by pushing the mainframe in at the top towards the wall in the wall profile.4. Ensure the enclosure is completely vertical using a spirit level.

Some important information to help you Maintain your product.

The following information is all you need to keep your product looking new.

Clean your product using a mild detergent diluted in water and then polished off using a soft cloth.

If you live in a hard water area, periodically clean your product using a 50/50 solution of white vinegar and water. The solution should be left on the enclosure for approximately 5 minutes then rinsed off using warm water. This method of cleaning should remove lime scale residue.

Simple Maintenance

Our products are generally maintenance free, however it may be necessary to lubricate wheel assemblies and other moving parts from time to time.

It is strongly recommended that a quality silicone spray is used.

A list of Don't's:

1. Don't use acidic based products which are unsuitable for cleaning enamel surfaces.
2. Don't use abrasive cleaners or cleaners using bleach or solvents, these products will adversely affect the finish of the aluminium profiles.
3. Don't use scouring pads, powder or any sharp instruments when cleaning the enclosure.

Should you experience any problems during installation please refer to the Trouble Shooting Guide or contact Customer Relations on:

+44 (0) 1325 328033

To enable customer relations to provide you with an excellent level of service it is important that you quote your product Code and Reference Number - these can be found on the Guarantee card.