

QD EBASNW C

QUADRATO Tap Range Quadrato Eco Basin Mixer without Waste



Features:

- Long life ceramic cartridge for added durability and ease of use
- Metal fixing nut for added durability
- Flexible tails included
- Supplied with 3.5 litre per minute flow limiting aerator to reduce water consumption and increase water efficiency
- Minimum working pressure of 0.5 bar

Product Certifications:



WRAS Cert. Number: 1612069
WRAS Expiry Date: 31/12/2021



For more products, visit our website:
<http://www.bristan.com>



Specification

Product Type:	Bathroom Taps
Main Construction Material:	Brass
Mount Type:	Deck Mounted
Handle Type:	Lever Handle
Connection Inlet:	1/2" Female Flexible Tails
Connection Outlet:	M24 Flow Straightener
Number of Tap Holes:	1
Valve/Cartridge Type:	35mm Ceramic Cartridge
Plumbing System Requirements:	Suitable for all plumbing systems
Minimum Dynamic Pressure (bar):	0.5 bar
Maximum Dynamic Pressure (bar):	5.0 bar
Maximum Hot Water Temperature °C:	65°C
Maximum Static Pressure (bar):	10 bar
Flow Type:	Single Flow
Isolation Included:	No

Dimensions (measurements in mm)

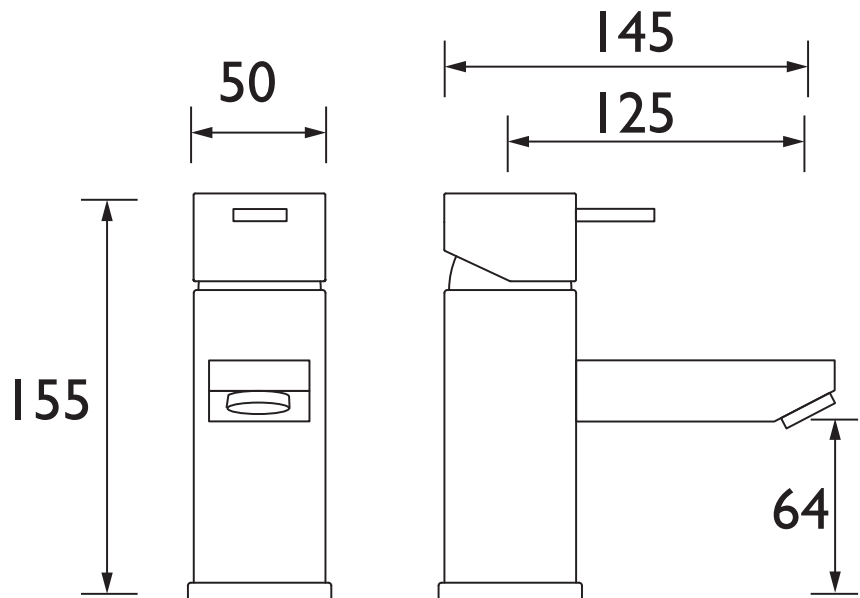

Flow Rates (l/min)

System Pressure (bar)	0.5	1	2	3	5
QD EBASNW C (mixed)	7.1	10	14.1	17.3	22.3

TECHNICAL DATA SHEET



BRISTAN

D10