

# Sliding Door

## Instruction Manual

### H4S

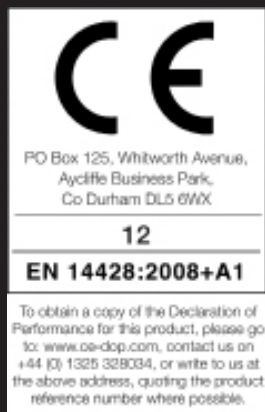

### IMPORTANT INFORMATION

- Toughened glass is completely safe for use in our shower enclosures and bath screens; providing our products are installed according to our guidelines.
- It is important to note that the glass must not be mounted or 'pinched' in such a way that would cause a stress point to develop in the glass. In addition, it must not be subjected to any sharp impact or severe temperature fluctuation which may also cause a stress point to develop in the glass.
- Toughened glass is physically and thermally significantly stronger than standard glass. During the toughening process the stresses contained within any glass are balanced so if in the unlikely event situation any of the above occurs and the glass breaks, the glass will shatter safely into small thumbnail sized blunt fragments.



#### PRE-INSTALLATION CHECKS

1. Check you have the correct product. Please look at the labels on the side of the product packaging.
2. Check all the product components are in the box and the fixing kits.
3. Unpack your product and handle it with care.
4. Please check the product for defects or damage, once the installation has commenced we cannot accept responsibility for any defects or damage.
5. Please take time to read these instructions prior to installing your product.
6. Before you commence any drilling check there are no hidden electrical cables and/or water pipes.
7. No attempt should be made to re-work the toughened safety glass.
8. The installation of the product should be performed by two persons.
9. It is strongly recommended that the walls the product is going to be installed on are vertical.
10. It is strongly recommended the product is fitted on a tiled surface or similar waterproof surface.
11. It is strongly recommended the walls are tiled and grouted before the product is installed.
12. If the walls and/or the tray are not level you will not achieve maximum adjustment of the product.
13. Pictures used are for illustration purposes only, product designs may alter slightly as a result of continuing product development.
14. We do not stipulate where the European Standard Kite Mark should be positioned on the glass when being factory assembled.
15. Please note that some natural misting may occur when you remove this product from its packaging, due to the addition of the glass protection pre-coating. If this does occur this can easily be removed with a soft, dry cloth.

#### Fixing Kit Components (Supplied)

Description	Quantity
2.5mm Drill Bit	1
Wall Plugs	6
40mm Screws	6
9mm Screws	6
Screw Bases	12
Screw Covers	12
13mm Frame Fixing Screws	8
Universal Caps	2
2.5mm Allen Key	1
3mm Allen Key	1
Branding Badge (if applicable)	1

#### Component Check List: Supplied

Description	Quantity
Wall Profiles	2
Door Vertical Profile	1
Horizontal Rail Assemblies	2
Panel to Rail Seal	2
Bearing Assemblies (Top)	2
Bearing Assembly (Bottom)	2
Door Glass	1
Flipper Seals	2
Door Handle	1
Panel Assembly	1
Magnet Seal Pairing	1

#### Equipment Check List: Not Supplied

Description
Mains or Battery Drill
6mm Masonry Drill Bit
Spirit Level
Pozi Screwdriver
Sealant Gun / Bathroom Sealant
Tape measure
Pencil
4.5mm Drill Bit

### CONSUMER GUARANTEE

Please make sure the purchaser/end user completes and returns the guarantee card which is enclosed with this product. Failure to validate the Guarantee will mean only the 1 Year Statutory Guarantee will apply.

Ref: V8T - Rev 5 July 2021  
H4S - Rev 5 Oct 2021

## Step 1 - Preparation

NOTE: The Sliding Door is designed to fit into an alcove between two tiled walls (as shown below) or with a return panel.

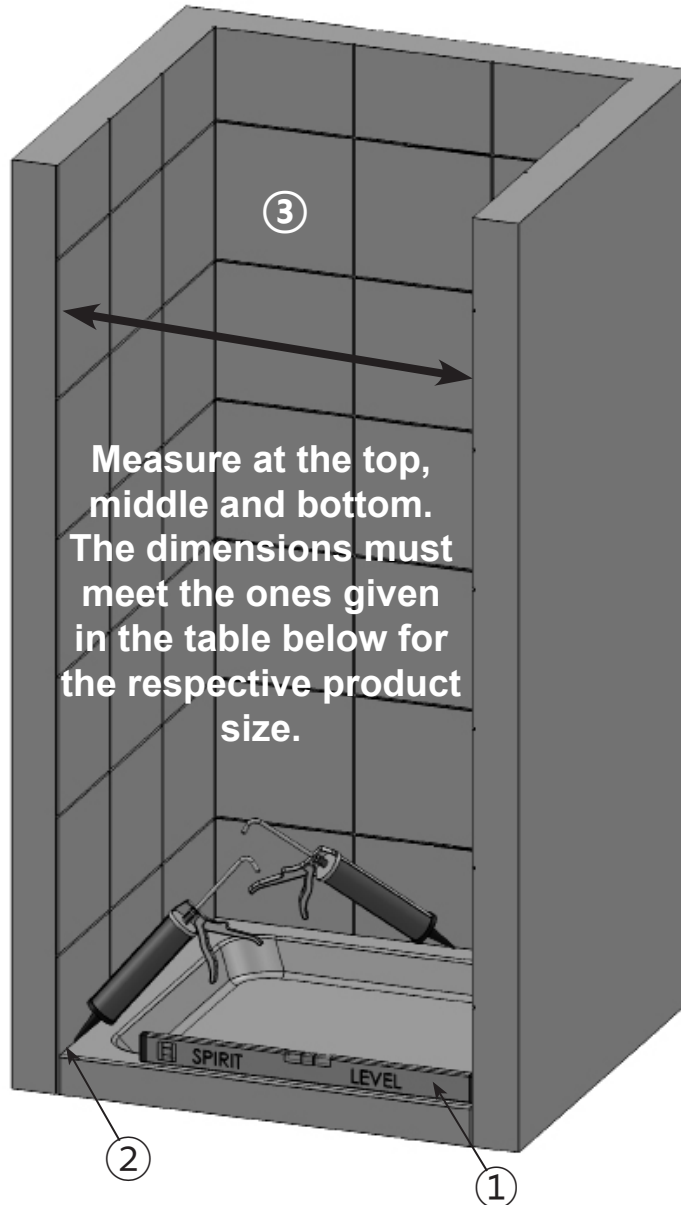

Product Code	Minimum Alcove Size	Maximum Alcove Size
V8T10	940mm	990mm
V8T11	1040mm	1090mm
V8T12	1140mm	1190mm
V8T14	1340mm	1390mm
V8T15	1440mm	1490mm
V8T17	1640mm	1690mm

1. Ensure the tray is completely level and check for any movement by standing in it - correct as necessary.
  - **Please ensure that the tray is installed as per the manufacturers instructions.**
2. Seal the tray fully along the tiled walls prior to installation with a bathroom sealant (not supplied).
  - **Prior to fitting the enclosure and when the sealant has fully cured, spray the shower handset over the joints and check for any leaks.**
3. **IMPORTANT:** Prior to installing/attempting to fit the Sliding Door into an alcove measure the opening at the top, middle and bottom after all tiling and grouting has been done. Check this against the dimensions given in the table shown above to see if your alcove meets the criteria.
  - **Check the plumbing for leaks.**
  - **Do not plasterboard over the tray.**
  - **Do not grout the tiles when the enclosure has been fitted as the grout may discolour the aluminium.**

## Step 2 - Fitting 1st Wall Profile (Alcove)

Note: If this product isn't being fitted in an Alcove but with a return panel then both wall profiles can be fitted now following the procedures below.

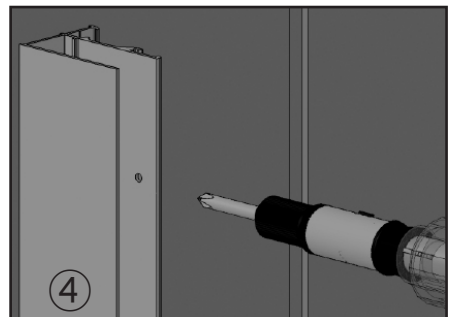
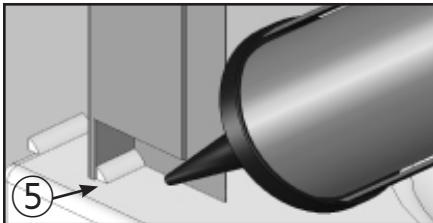
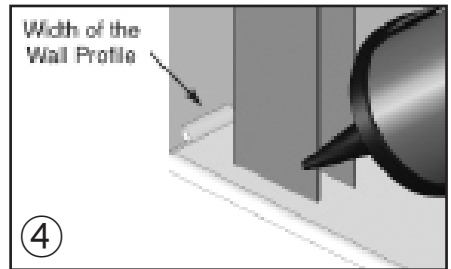
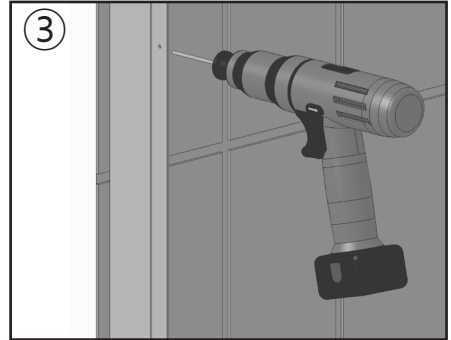
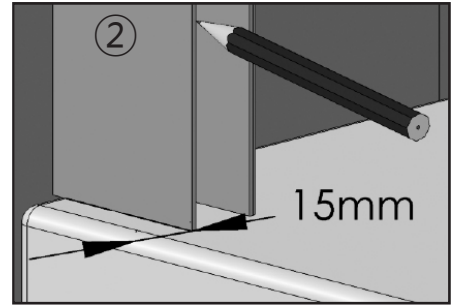
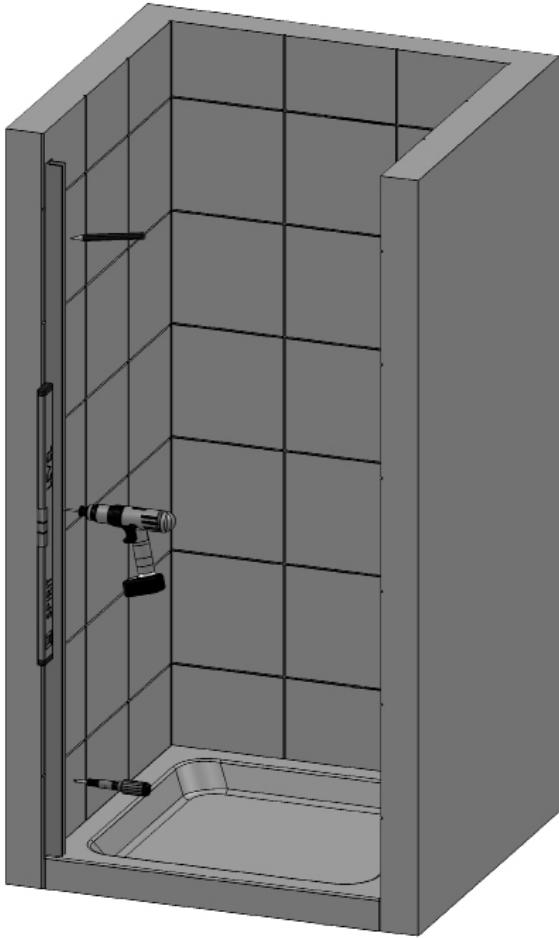

1. Decide which side of the alcove the fixed/panel side of the enclosure is to be fitted. Drill three 4.5mm holes into the U-Channel on the wall profile, approximately 100mm from each end and the last one positioned in the centre.
2. Place the wall profile 15mm in from the outside of the tray, the lip section of the wall profile must face inward towards the shower. Make sure the wall profile is completely vertical using a spirit level and mark the wall through the slots with a pencil.
3. Drill the wall with a 6mm Masonry Drill Bit (not supplied) where the Wall Profile is to be positioned. Fit the Wall Plugs supplied (if going in to a brick or block wall). If going into a plasterboard wall you will need to purchase appropriate wall fixings. Wipe clear all debris from the Tray before referring to the next stage.
4. Where the Wall Profile is to be positioned on the Tray, place a bead of Bathroom Sealant (not supplied) the width of the Wall Profile along the tiled wall. Screw the Wall Profile to the wall with 40mm Screws (supplied). Do not over tighten the screws into the Wall Profiles as this will misshape the Wall Profile. Ensure the Wall Profile stays completely vertical throughout this procedure using a Spirit Level.
  - **Failure to carry out this procedure correctly can result in serious water damage and is not covered by the Guarantee.**
  - **No sealant should be present between the Wall Profiles and the tiled walls vertically prior to screw fixing.**
5. Seal the gap on the inside between the Tray and Wall Profile with a Bathroom Sealant (not supplied).
  - **Failure to carry out this procedure correctly can result in serious water damage and is not covered by the Guarantee.**

### Step 3 - Preparing the 2nd Wall Profile (Alcove)

NOTE: This Wall Profile is to be fitted to the side of the alcove where the door opening is to be.

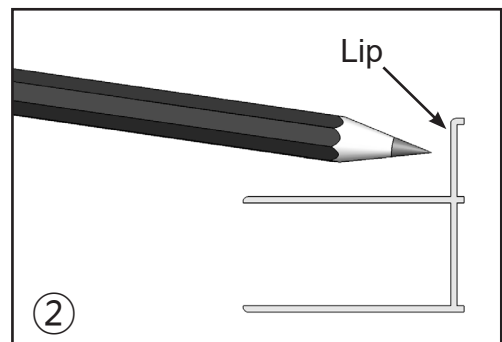
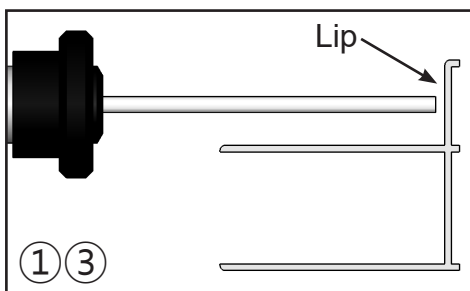
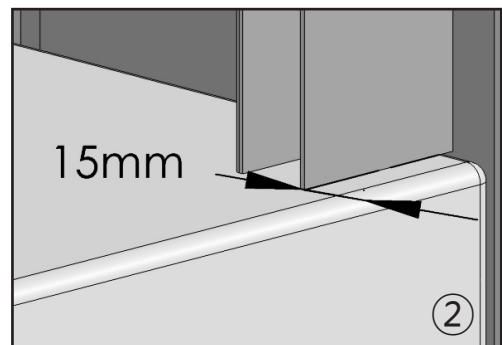
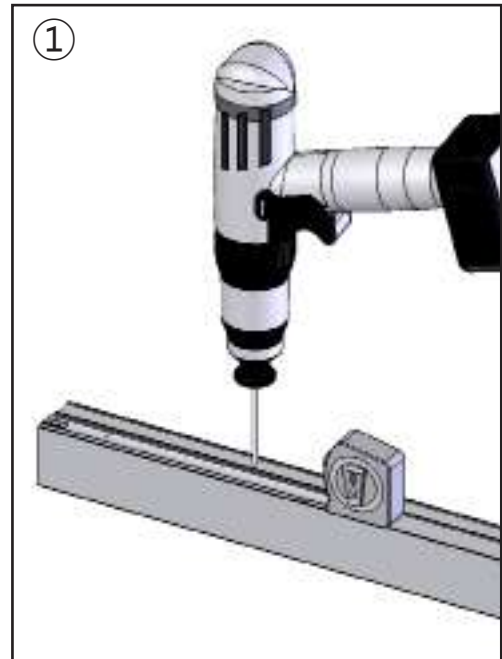
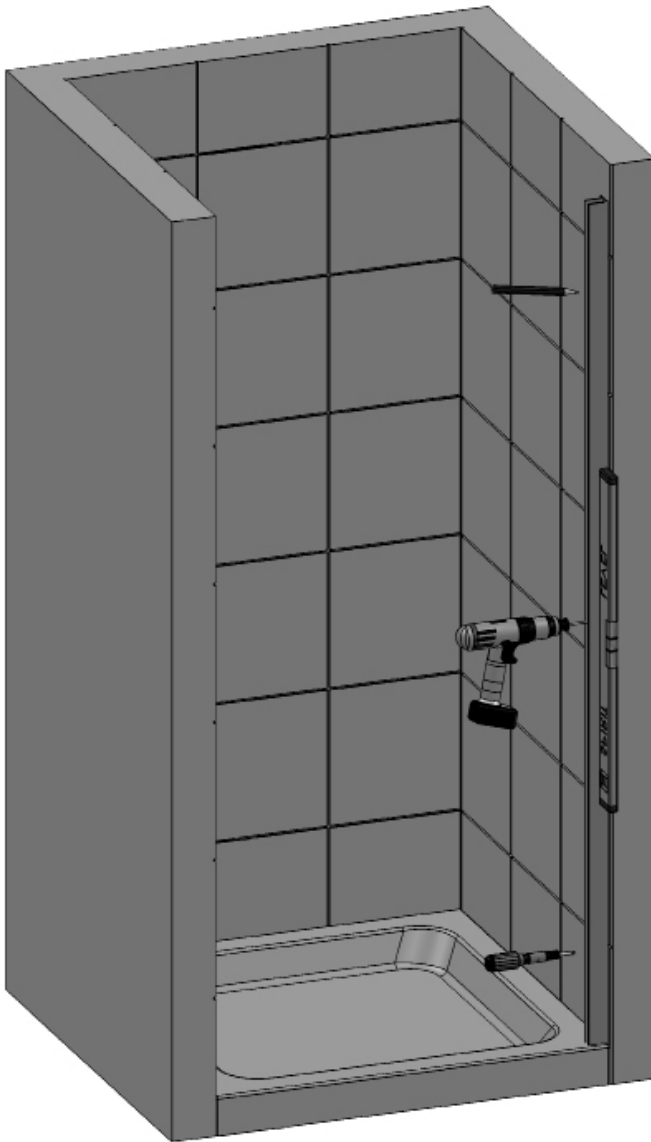

1. Take the remaining wall profile and drill three 4.5mm holes into the lip, approximately 100mm from each end and the last one positioned in the centre.
  - **Drill the holes through the face that goes to the wall - deburr all holes.**
2. Place the wall profile 15mm in from the outside of the tray so that it matches the 1st wall profile, the lip section of the wall profile must face inward towards the shower. Make sure the wall profile is completely vertical using a spirit level and mark the wall through the slots with a pencil.
3. Drill the wall with a 6mm Masonry Drill Bit (not supplied) where the Wall Profile is to be positioned. Fit the Wall Plugs supplied (if going in to a brick or block wall). If going into a plasterboard wall you will need to purchase appropriate wall fixings.
  - **IMPORTANT: Do not fit the wall profile at this stage, it will be fitted to the wall later in the installation.**

## Step 4 - Assembling the Frame

**IMPORTANT:** The Horizontal Rails are handed, to determine which rail goes where look at the screw hole for the glass clamp. This is slightly off centre and should go towards the glass.

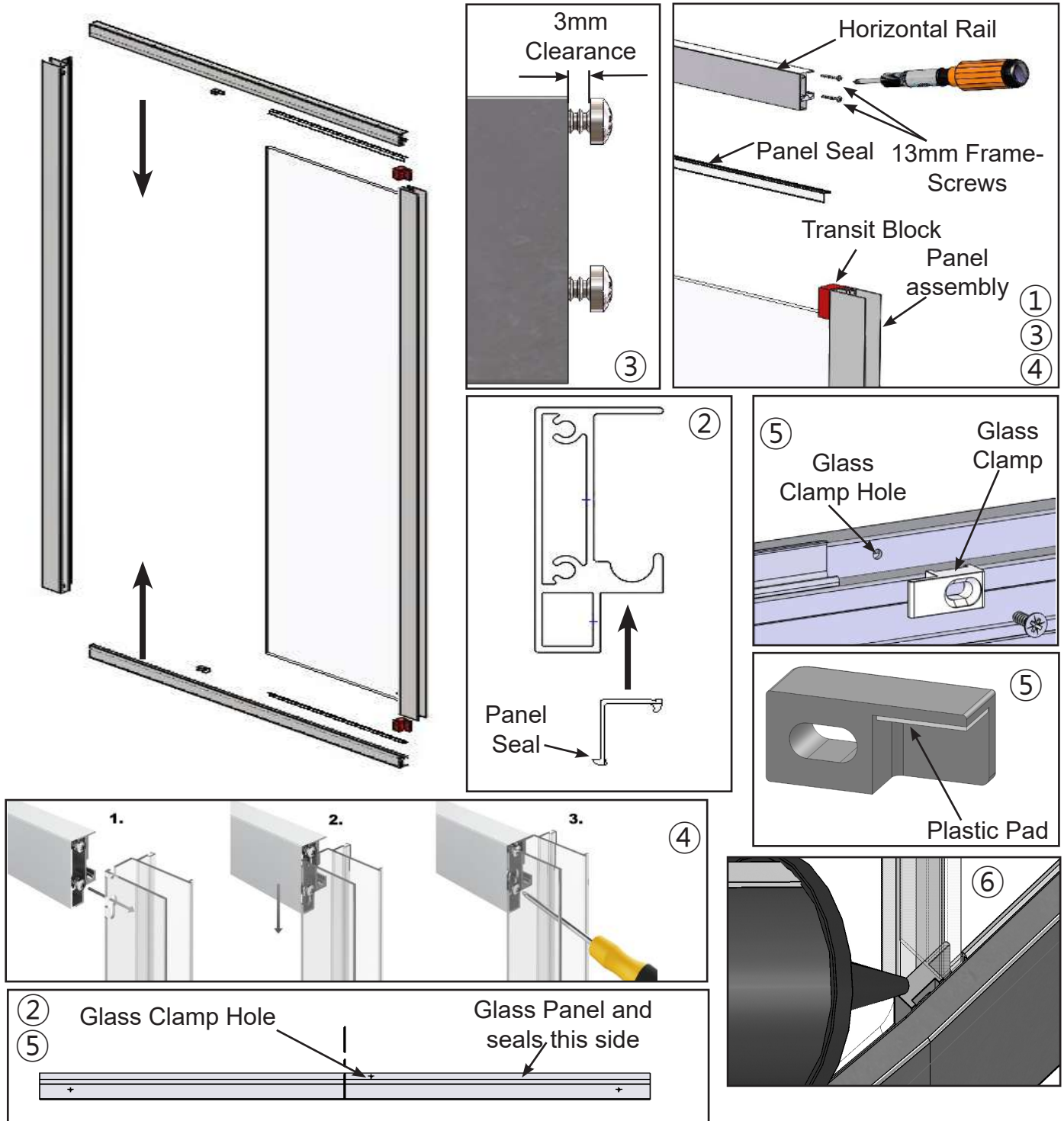

1. Prior to assembling the frame remove both Transit Blocks from the Panel assembly and discard.
2. Place the "L" shaped Panel Seals between the glass and Horizontal Rails at both the top and bottom making sure that they butt up fully to the Panel Assembly Vertical.
  - **NOTE: There is a long side and short side to the seal, make sure you fit the seal the correct way.**
3. Screw the 13mm Frame Screws in the glass panel side of the horizontal rail and in the door vertical aluminium side, ensure there is a 3mm clearance between the screw head and the aluminium.
4. Following the fast fix system steps as shown above slot horizontal rail into the key slot holes on the panel assembly vertical aluminium, drop it into position and adequately tighten. Repeat with the other horizontal rail followed by the magnet carrier vertical aluminium on the opposite side.
  - **IMPORTANT: Use a hand screwdriver in order to NOT over stress the screws.**
5. Screw fit the glass clamps to both Horizontal rails securing the glass in place ( Note: the glass clamps are handed - left hand shown). Ensure the plastic pad is between the top of the glass and the clamp.
6. Seal the gaps in the glass clamps with silicon sealant to prevent leaking from this area.

## Step 5 - Installing the Frame and Fixing the 2nd Wall Profile (Alcove)

NOTE: The stages below will require 2 people to carry them out. On stage 4 when lifting the Frame to seal the inside of the 2nd wall profile place a wooden chock or similar between the enclosure and the top of the tray to prevent it from falling and causing injury (carefully remove when done).

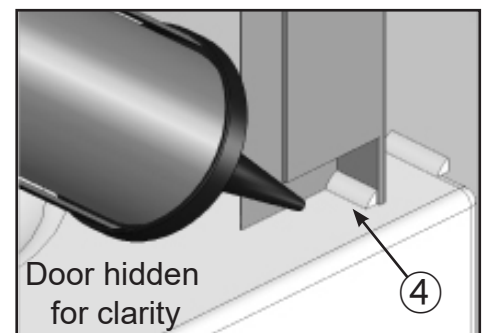
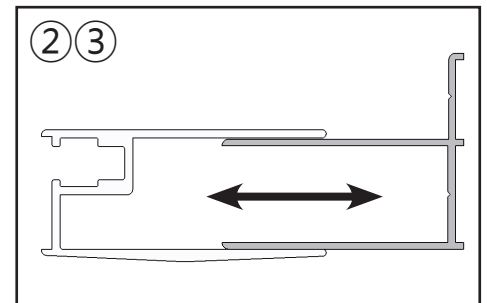
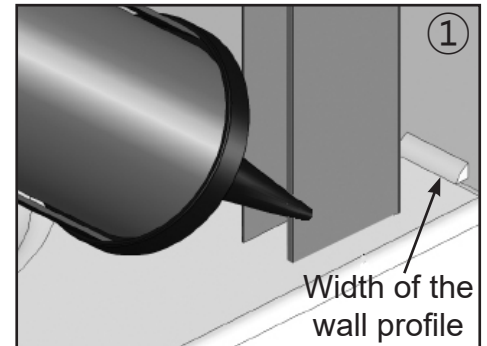
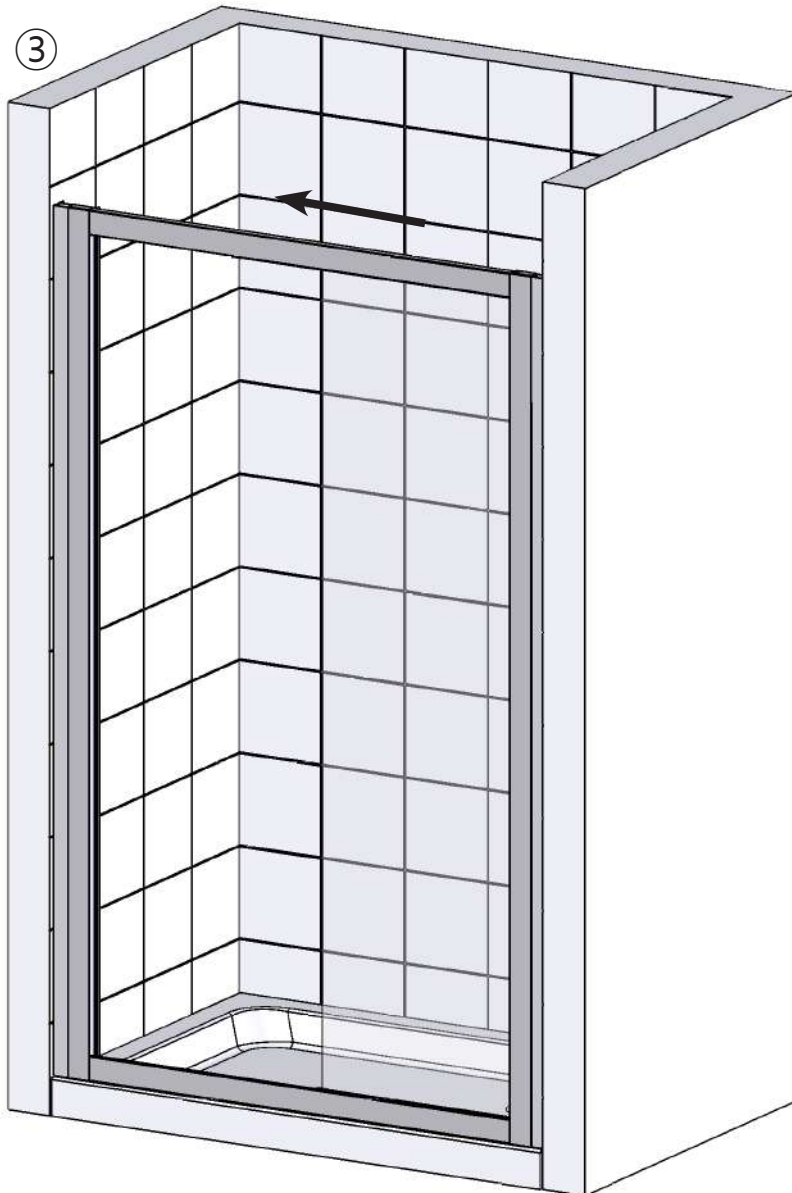

1. Prior to fixing the 2nd wall profile apply a bead of Bathroom Sealant (not supplied) the width of the wall profile where it meets the tiled wall and tray at the bottom.
2. Carefully place the Frame over the already fitted (1st) wall profile which you decided in Step 2 and push fully together.
  - **NOTE: The Wall Profile fits inside the Frame Vertical .**
3. Place the 2nd Wall Profile over the other end of the Frame as far as it will go and then push it back to the wall. Fit the screw bases to the 40mm screws and screw fix through the lip and fit the cover caps.
4. Carefully lift the Frame and seal the gap on the inside between the Tray and Wall Profile with a Bathroom Sealant (not supplied).
  - **IMPORTANT: Failure to carry out Stages 1 and 4 can result in serious water damage and is not covered under the terms of the guarantee.**
  - **Ensure that the panel end of the enclosure is fitted to your 1st wall profile.**
  - **The wall profiles must be completely vertical (the bubble on the Spirit Level must be in the centre of the 2 lines).**

## Step 6 - Fixing the Frame to the Wall Profiles

NOTE: The stages below will require 2 people to carry them out.

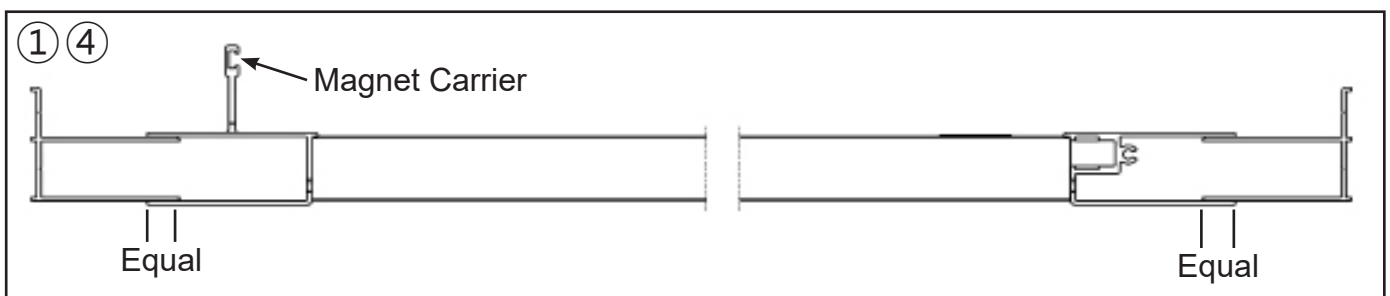
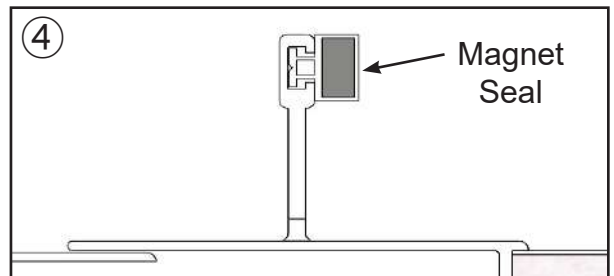
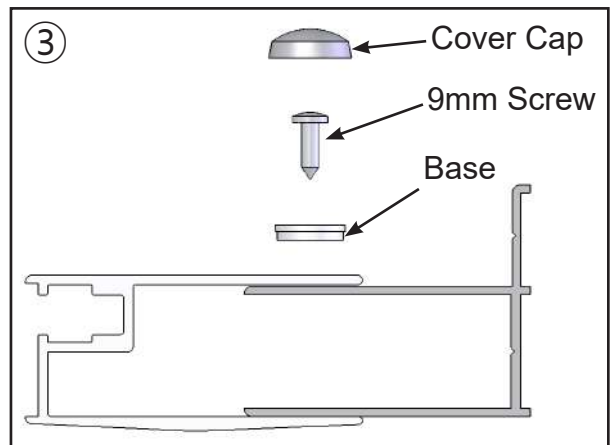
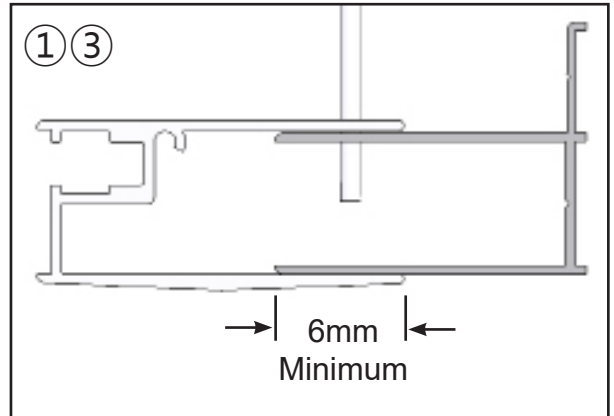
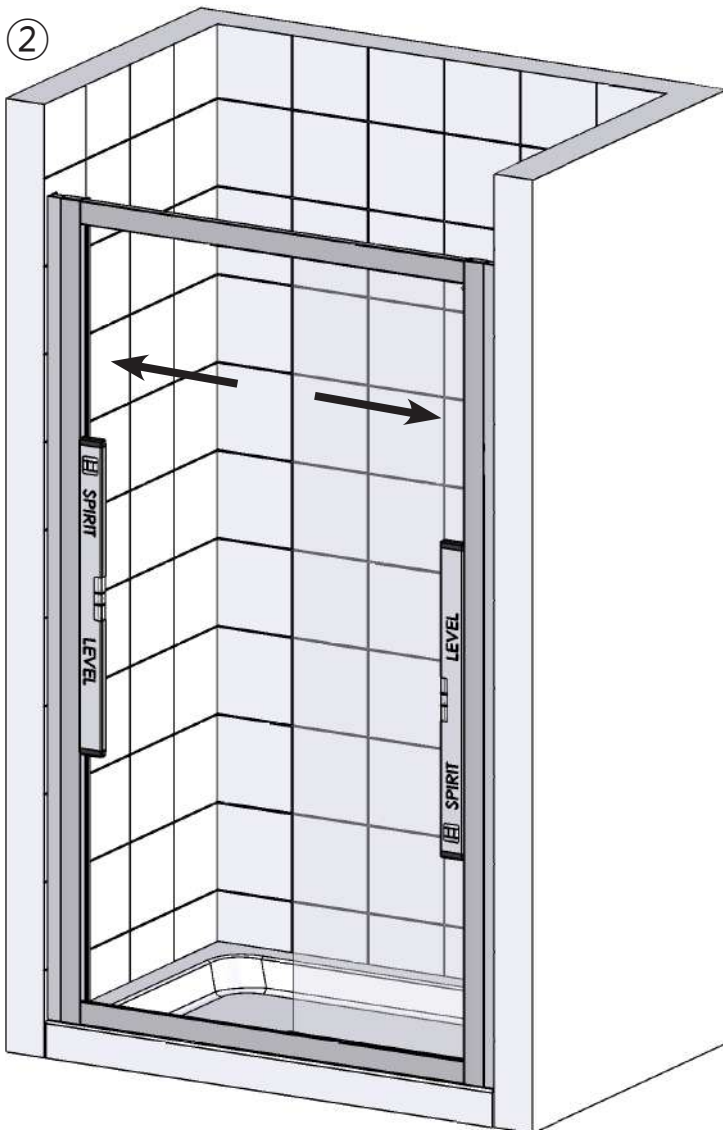

1. Centralise the Frame between the wall profiles.
  - **IMPORTANT: There must be a minimum of 6mm for fixing.**
2. With a Spirit Level keep the framework completely vertical then drill 3 holes in each frame vertical profile approximately 100mm from the top and bottom and one in the centre into the Wall Profiles with the 2.5mm drill supplied.
  - **Ensure the Frame is completely vertical (the bubble on the Spirit Level must be in the centre of the 2 lines).**
3. Place the bases onto the 9mm screws and screw fix the frame to the wall profiles and check that the Frame is still vertical, when satisfied push on the cover caps.
4. Slide the Frame Magnet Seal into the magnet carrier aluminium, trim to length if required.

## Step 7 - Fitting the Door

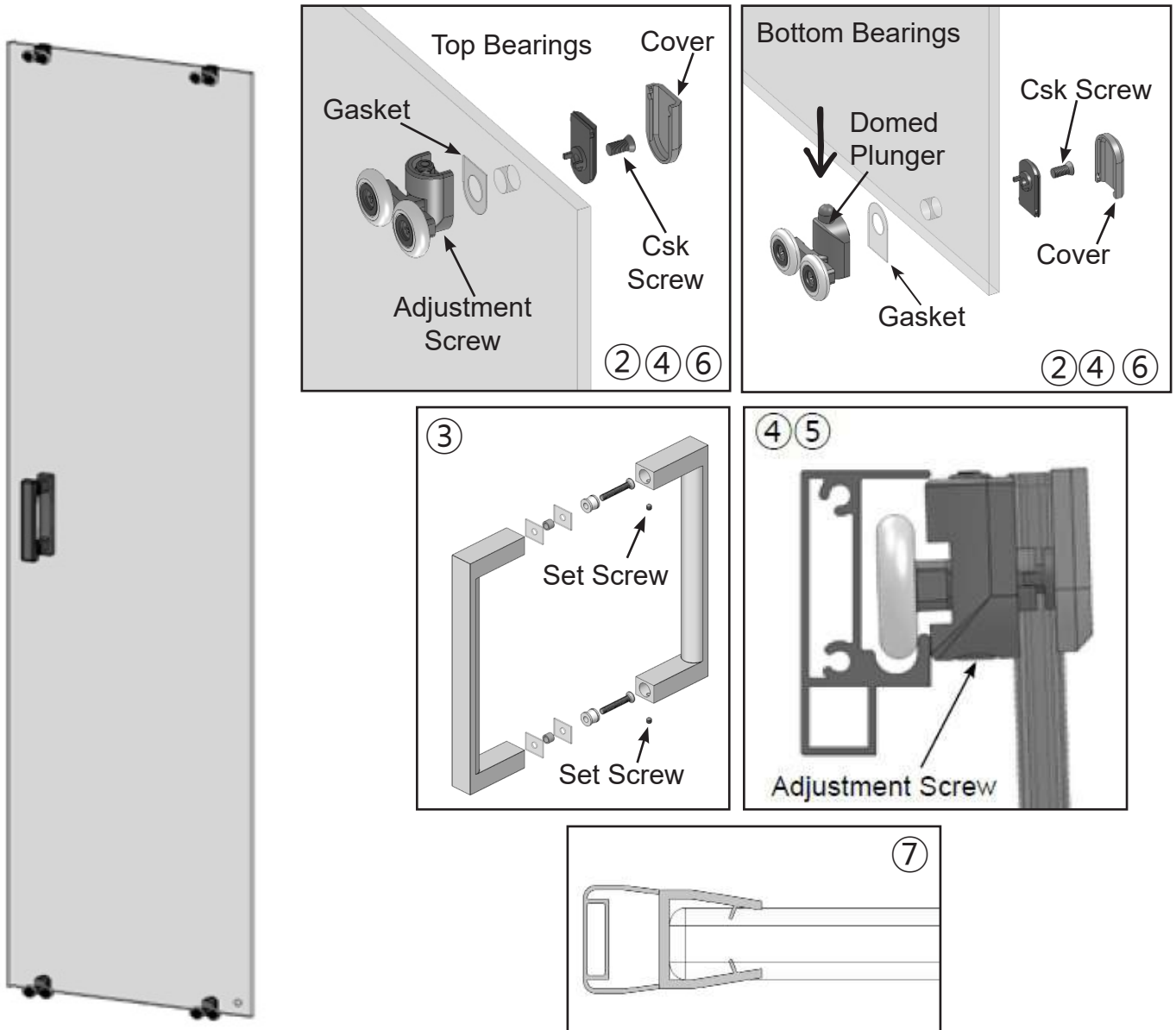

1. Place the Door Glass onto a level scratch free surface.
2. Carefully dismantle the Bearing Assemblies, place the gasket on the outside of the glass (Bearing Side) then re-assemble onto the Door Glass. Make sure you have the correct bearings at the top and bottom and that the wheels are on the outside of the glass.
  - **IMPORTANT: Fit the Bearing Assemblies to the door using a hand screwdriver only (Do NOT use a Drill).**
  - **NOTE: The bottom bearings have a domed plunger.**
3. Remove the handles from the packaging, using the Allen Keys (supplied) remove the screws and split the handle assemblies. Fit onto the door glass ensuring the Set Screws are on the inside of the enclosure.
4. Carefully place the assembled door inside the tray. With the Door the correct way round offer the Top Bearings into the top Horizontal Rail, when in position lower the Door and press the plungers down on the Bottom Bearing assemblies so that the Door can be placed into the Bottom Horizontal Rail.
  - **NOTE: When fitting to the top offering the door at a slight angle will make it easier to fit into the rail.**
5. There is a screw in the Top Bearings for adjustment purposes, adjust as necessary to align the Door.
6. When satisfied with the fitting of the Door fit the Inner Bearing Covers.
7. Fit the magnet seal onto the door glass on the closing side (magnet aluminium side) and trim to length if required.

## Step 8 - Sealing

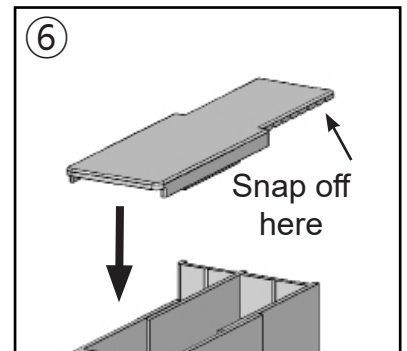
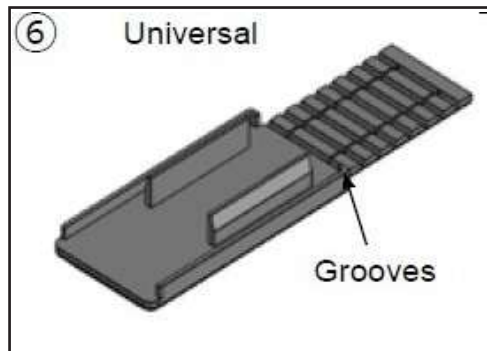
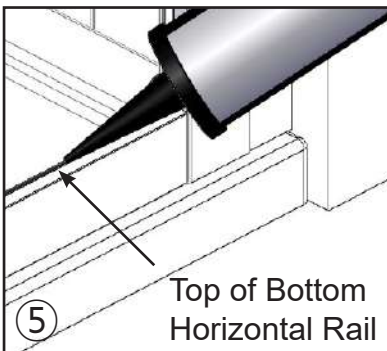
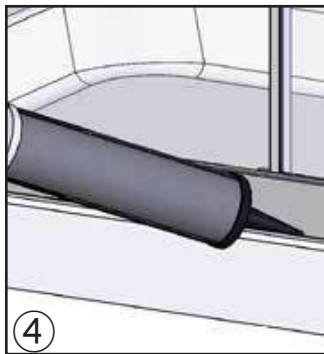
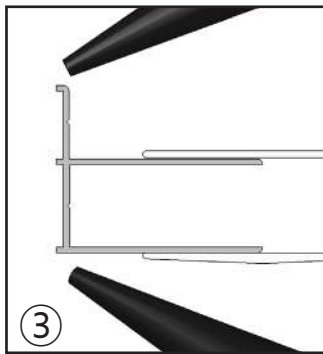
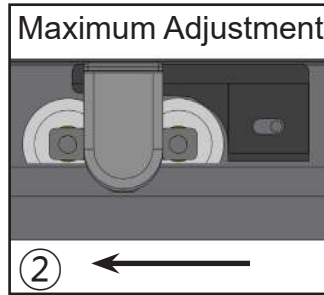
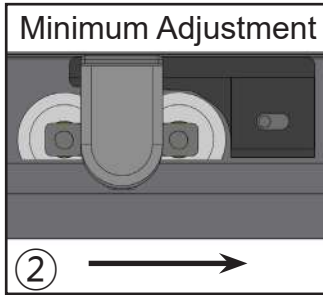
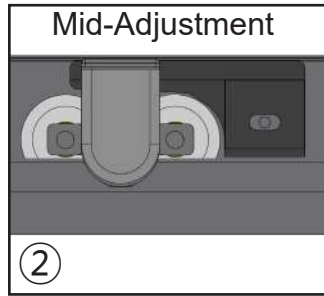
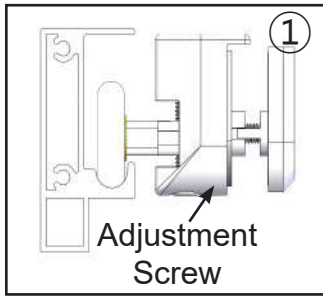

1. The Door can be adjusted by turning the Screws on the Top Bearing Assemblies using a screwdriver. Turn the screws up or down until you are satisfied with the Door.
2. With the Door adjusted, fit the Door Stops so they just make contact with the wheel of the bearing when open, this is to prevent excessive movement and rocking. The Door Stops can be moved left-to-right so that the wheel contacts it between its minimum and maximum adjustment (see diagrams).
  - **IMPORTANT: Adjust the Door Stops top and bottom, failure to do so may result in breakages.**
3. Using a good quality sealant, seal both sides of the Wall Profiles vertically inside and outside where they meet the tiled Walls.
4. Fully seal the Bottom Horizontal Rail to the top of the tray on the outside only from wall to wall.
5. Fully seal horizontally between the top of the Bottom Horizontal Rail and the Panels Glass on the outside.
  - **IMPORTANT: Failure to carry out stages 3, 4 and 5 may result in serious water damage and is not covered under the terms of the guarantee.**
  - **DO NOT seal the base of the product to the inside, failure to comply may result in the product leaking.**
6. Fit the Universal Top Caps, these can be shortened to fit by snapping off at the relevant groove. Apply a small amount of silicon to the underside to help keep in place.
7. Fit the door and panel flipper seals onto the edge of the glass.
8. Please allow 24 hours for the sealant to cure prior to using the enclosure.
9. Place the branding badge in a prominent position on a none moving part of aluminium.

## Spare Parts

If you need to replace any damaged parts please see illustration below for parts list then call Customer Relations on 01325 328033

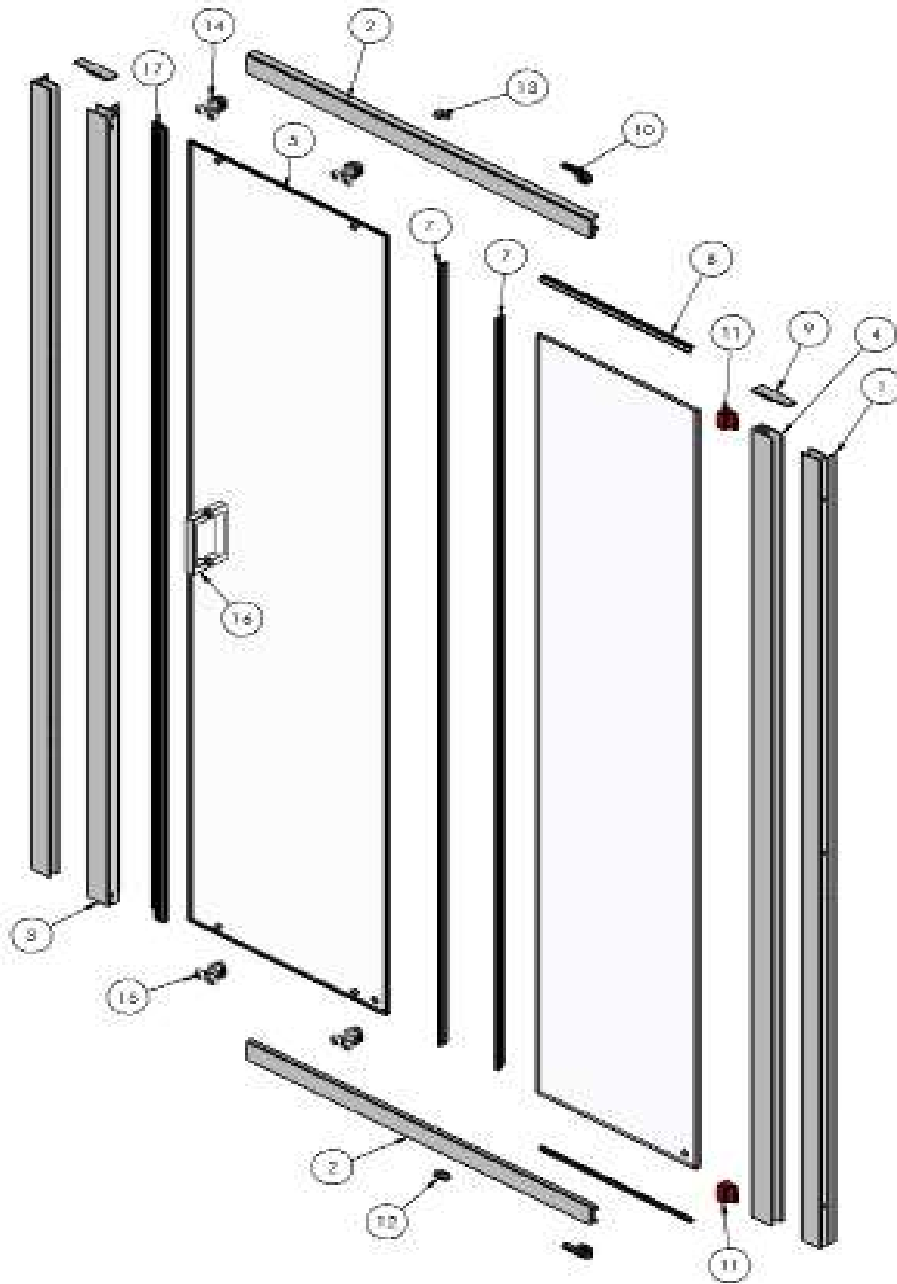

Part No.	Description	Q'ty	Part No.	Description	Q'ty	Part No.	Description	Q'ty
1	Wall Profile	2	11	Setting Block	2			
2	Horizontal Aluminium	2	12	Glass Clip RH	1			
3	Door Vertical (Right Hand)	1	13	Glass Clip LH	1			
4	Panel Vertical	1	14	Top Bearing	2			
5	Door Glass	1	15	Bottom Bearing Assembly	2			
6	Panel Glass	1	16	Luminate Handle	1			
7	8mm Flipper Seal	2	17	Magnet Seal Pairing	1			
8	8mm Panel Seal	2						
9	Universal Top Cap	2						
10	Door Stop	2						

## TROUBLE SHOOTING GUIDE

Problem	Solution
<b>Leaking</b>	<ol style="list-style-type: none"><li>1. Check the tray is sealed correctly along the tiled walls prior to installation.</li><li>2. Check that the inside gap between the Tray and Wall profiles has been sealed correctly.</li><li>3. Check the base of the enclosure is sealed on the outside only.</li><li>4. Check that a bead of sealant the width of the wall profile has been applied.</li><li>5. Check the wall profiles on the tiled walls are sealed both vertically inside and outside.</li><li>6. Check all the seals have been cut and positioned correctly.</li></ol> <p><b>Important: This enclosure should be water tested conforming to BS EN 14428</b></p>
<b>Enclosure Alignment on the Tray or Floor</b>	<ol style="list-style-type: none"><li>1. Check the enclosure has been fitted onto a tiled wall or similar sealed surface.</li><li>2. Check that the wall profiles are fitted 15mm in from the front of the tray.</li><li>3. Check the wall profiles are completely vertical.</li><li>4. Check that the enclosure is completely level and vertical.<ul style="list-style-type: none"><li>• <b>The bubble on the spirit level must be in the centre of the 2 lines.</b></li></ul></li></ol>
<b>Door not operating / closing correctly</b>	<ol style="list-style-type: none"><li>1. Check the tray is completely level, this could have an effect on the positioning of the door when adjusted. You may not have enough adjustment within the wall profile due to compensating for an out of level tray.</li><li>2. Check the wall profiles are completely vertical.</li><li>3. Check the channels that the door slides in has some lubrication gel in it ( If not please apply some form of lubricating agent in the channels).</li><li>4. If the door does not hang vertically you have adjustment at the top of each Wheel Bearing Assembly, turning the screws clockwise will lift the door likewise anticlockwise lowers the door.</li><li>5. Rotate the Door Stops to prevent rocking.</li></ol>

### Some important information to help you Maintain your product.

The following information is all you need to keep your product looking new.

Clean your product using a mild detergent diluted in water and then polished off using a soft cloth.

If you live in a hard water area, periodically clean your product using a 50/50 solution of white vinegar and water. The solution should be left on the enclosure for approximately 5 minutes then rinsed off using warm water. This method of cleaning should remove lime scale residue.

### Simple Maintenance

Our products are generally maintenance free, however it may be necessary to lubricate wheel assemblies and other moving parts from time to time.

It is strongly recommended that a quality silicone spray is used.

### A list of Don't's:

1. Don't use acidic based products which are unsuitable for cleaning enamel surfaces.
2. Don't use abrasive cleaners or cleaners using bleach or solvents, these products will adversely affect the finish of the aluminium profiles.
3. Don't use scouring pads, powder or any sharp instruments when cleaning the enclosure.

Should you experience any problems during installation please refer to the Trouble Shooting Guide or contact Customer Relations on:

**+44 (0) 1325 328033**

To enable customer relations to provide you with an excellent level of service it is important that you quote your product Code and Reference Number - these can be found on the Guarantee card.