

# PRODUCT DATA SHEET

## Lunar Chrome Square Rigid Riser Shower

Product Code: SHOWER003N



**SCUDO**  
BEAUTIFUL BATHROOMS

0330 124 7290

sales@scudo.co.uk - www.scudo.co.uk

Scudo is the trading name of Harrison Bathrooms Ltd. Whilst we endeavour to ensure that the product information is accurate we accept no liability for any information given. All images are for illustration purposes only. Product images and specification are subject to change. Measurement are in millimetres and are nominal.

### Product Measurements

Product Weight:	5kg
Product Width:	263mm
Product Height:	860-1230mm
Product Depth:	420mm
Product Length:	N/A

### Product Transportation

Barcode:	5060500640576
Country of Origin:	China
Comodity Code:	8481801190

### Primary Packed Measurements

Packaged Weight:	5.32kg
Packaged Length:	745mm
Packaged Width:	415mm
Packaged Height:	80mm

### Packaging Weight

Card:	0.455kg
Plastic:	N/A

### General Information

Construction Material:	Brass / Plastic / Stainless Steel
Installation Type:	Wall Mounted
Colour / Finish:	Chrome

### Shower Specification

Anti-Scald:	Yes
Shower Diverter Functions:	Yes
Number of Outlets:	1
Thermo Temp Control:	Yes
Cool Touch:	No
Shower Handset Functions:	1
Minimum Working Pressure:	0.5
Maximum Working Pressure:	5
Shape:	Square
Pipe Centre:	150mm
Inlet Connection:	3/4 BSP
Outlet Connection:	1/2 BSP Handset
Adjustable:	Yes
Adjustment:	935-1250mm
Handle Type:	Square

### Flow Rates

0.2bar (l/min)	4
0.5bar (l/min)	8.4
1bar (l/min)	12.7
2bar (l/min)	18.1
3bar (l/min)	22.2

### Compliance DOP

HBDOC042 / HBDOC043

### Spares

Diverter: T43004-08 Thermostatic Cartridge: H104

### Tap Attributes

Tap Type Description:	Exposed Bar Valve
Includes Waste:	N/A
Valve / Cartridge Type:	Thermo & 1/4 Turn Cartridge

For Part G Building regulations, compliance see flow regulator section of spec binder.

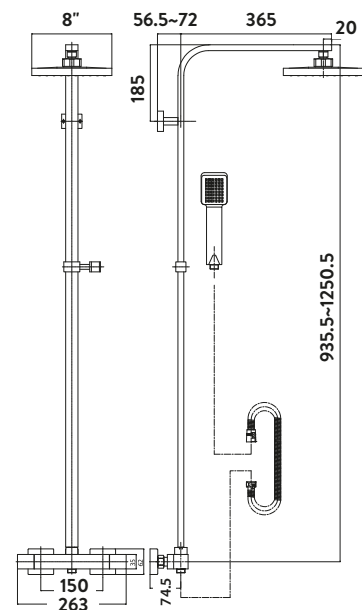

### Dimensions

(measurements in mm)



#### LIFETIME GUARANTEE

We are confident in our products and we want our customer to be, we proudly give a lifetime guarantee on our taps and showers, further details can be found on our website