

**TS4503/TS4753 GROUP CONTROL  
THERMOSTATIC MIXING VALVE**

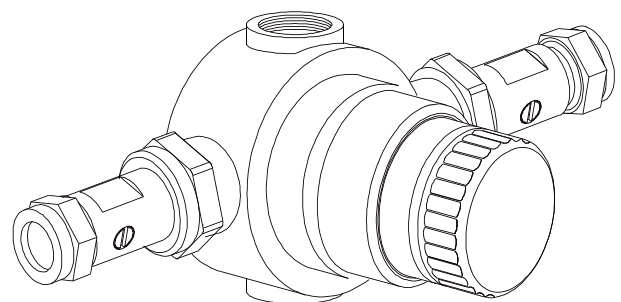

**INSTALLATION, MAINTENANCE  
AND OPERATING GUIDE**

**A & J GUMMERS LTD**  
 UNIT H, REDFERN PARKWAY  
 TYSELEY, BIRMINGHAM  
 B11 2DN, ENGLAND  
 TEL: 0121 706 2241  
 FAX: 0121 706 2960

**SERVICING / MAINTENANCE:**

- \* This valve does not normally require regular maintenance due to the hard wearing materials used within the valve. However in hard water areas it is recommended to service it annually to ensure optimum performance.
- \* To do this the following procedure will apply:
- \* Turn both isolating balls (28) to shut off both Hot and cold supplies (see fig. 3.)
- \* Unscrew isolator nuts (28) from body (17), unscrew grubscrew from backplate and remove valve assembly from wall and isolating adaptors.
- \* Remove filters from isolating adaptors (28) and rinse through with cold water to remove any debris.
- \* Remove knob insert (1) undo and remove retaining screw (2). Remove control knob (3) , plain ring (6) and sleeve (4), exposing head assembly.
- \* Remove head (5) from body (17) by using a 29mm A/F spanner, and remove bottom cap (21), piston assy (19) together with thermostat (15) and return spring (20). N.B. The piston assy (19) can be dismantled further, but is not necessary for general cleaning / servicing.
- \* Soak all metal parts in de-scalent and wash off in clean water.
- \* Lightly grease all parts with silicone grease and replace any worn or damaged 'O' ring seals.

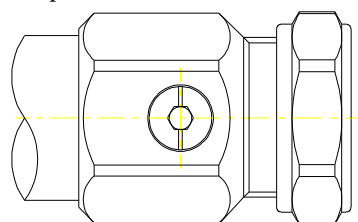

**Fig 3. orientation of slot in Shut off position.**

**Re-assembly.**

- \* Replace piston assy (19) ensuring ease of movement when in place (Piston should move with light finger pressure).
- \* Replace spring (20) and bottom cap (21). It is important that the bottom cap is screwed in gently until it bottoms onto piston face (do not use excessive force).
- \* The bottom cap (21) should then be unscrewed 1.1/4 turns to give the correct gap between piston and bottom cap.
- \* Re-assemble head (5-14) and ensure adjusting screw is screwed back fully.
- \* Fit thermostat (15) into head assy and screw head assy into valve.
- \* Refit sleeve (4) and knob (3) and secure with retaining screw (2).
- \* Refit valve onto wall, secure to backplate with grubscrew and reconnect to isolators by tightening nuts (28) ensuring filters have been replaced.
- \* Finally reset temperature (see operation and temperature setting).

**INSTALLATION:**

- \* It is important that both supply pipes are flushed before connecting mixing valve to ensure no pipe/plumbing debris enters mixing valve.
- \* We recommend fitting strainers to ensure no debris enters the mixing valve.
- \* In hard water areas the mixing valve may require more frequent cleaning/servicing.
- \* Before mounting the valve to the wall the position for pipework should be decided.
- \* By removal of the backplate the valve body base clearly identifies the hot and cold inlets. It is important to connect these correctly.
- \* Use the backplate (24) as a template to mark position of the fixing holes.
- \* Drill and plug the wall to suit screws provided and secure backplate (24) to wall.
- \* Locate valve body into the backplate and lock with grubscrew.
- \* Connect inlet pipes to isolators.
- \* Top or bottom outlet can be achieved by simply using the blanking plug (26) and 'o' ring (27) to blank off outlet not required.

MINIMUM PRESSURE DROP THROUGH FITTING FOR CORRECT MIXING	0.1 BAR (1Metre head)
MAXIMUM PRESSURE DROP THROUGH FITTING FOR CORRECT MIXING	5.0 BAR (50 metre head)
MAXIMUM STATIC PRESSURE TO BE APPLIED TO FITTING	10.0 BAR (100 metre head)
MAXIMUM PRESSURE LOSS RATIO	10:1 EITHER SUPPLY
TEMPERATURE STABILITY WITH NORMAL VARIATION OF SUPPLY TEMPERATURES AND PRESSURES	± 1°C from set temperature
FACTORY SET STANDARD BLEND TEMPERATURE	43°C (Can be reset on site between 30°-55°C
MAXIMUM HOT SUPPLY TEMPERATURE	80°C

**PERFORMANCE**

PRESSURE DROP (BARS)	0.1	0.2	0.4	0.6	0.8	1.0	1.5	2.0	3.0	4.0	5.0
TS4503	12	18	28	35	41	46	55	61	75	88	101
TS4753	17	26	39	49	56	63	77	89	109	125	142

FLOW RATES IN LITRES/MIN ON EQUAL PRESSURE DROPS AT MID BLEND POSITION.

**OPERATION AND TEMPERATURE SETTING:**

\* This valve is factory set at 43C but slight adjustment may be necessary depending on the installation.

\* To adjust the temperature supply ensure that the water is flowing and remove the knob insert (1) from the valve. Using a narrow bladed screwdriver, insert it through the retaining screw (2) until it is located in the slot of the adjusting screw (12). (fig 1).

\* Turn adjusting screw clockwise for cooler temperature.

\* Turn adjusting screw anti-clockwise for warmer temperature.

\* When the water is flowing at a desirable Temperature simply replace the knob insert (1).

\* For locked control position knob (3) so that the stops found on the inside of the knob are each side of the lug in the sleeve (4). Screw in retaining screw (2), set temperature (as above) and replace the knob insert (1). The valve is factory set in this position.

\* For limited temperature adjustment position knob (3) with the stops to the left of the lug in the sleeve (4). Screw in retaining screw (2), set temperature (as above) and replace the knob insert (1).

\* This valve is factory set at a high pressure with the bottom cap (21) open 3/4 turn. The hot arrow on the serial sticker on the bottom cap (21) will be pointing towards High on the sticker on the bottom of the valve body (17). To change to Low pressure turn the bottom cap (21) anti-clockwise 1/4 turn until the Hot arrow points towards Low on the sticker on the bottom of the valve body (17).

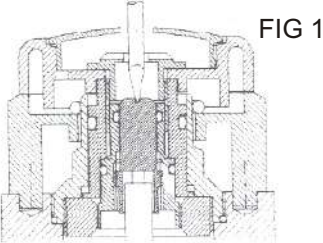

PARTS LIST					
1	KNOB INSERT	780072BL-4753	21	O' RING	480220
2	CONTROL KNOB	240391BL	22	PISTON ASSEMBLY	320081
3	RETAINING SCREW	700903	23	O' RING	480128
4	SLEEVE	760099BL	25	RING	360073
5	HEAD	680032	26	BACKPLATE	220017
6	SPINDLE NUT	700901	27	RETURN SPRING	360121
7	O' RING	480117	28	BOTTOM CAP	560505
8	ADJUSTMENT HOUSING	700902	31	CHECK VALVE	970041
9	O' RING	480016	34	ISOLATING ADAPTOR	970640CP
10	ADJUSTING SCREW	560550	35	WASHERS	760078
11	O' RING	480050	36	SCREW	560608
12	P T F E WASHER	300950	37	SCREW CAP	760071
13	HEXAGON INSERT	790403	38	CONCEALING PLATE	220021
15	THERMOSTAT	740012	39	GRUBSCREW	540586
16	O' RING	480030	40	ALLEN KEY	760072
17	BODY	150510	41	O' RING	480241
18	O' RING	480492	42	FILTER	780621
19	BLANKING PLUG	780173	43	FILTER PLATE	780623
			44	SCREW	560604

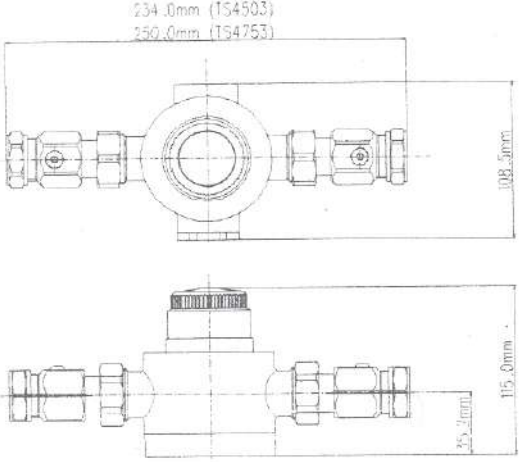
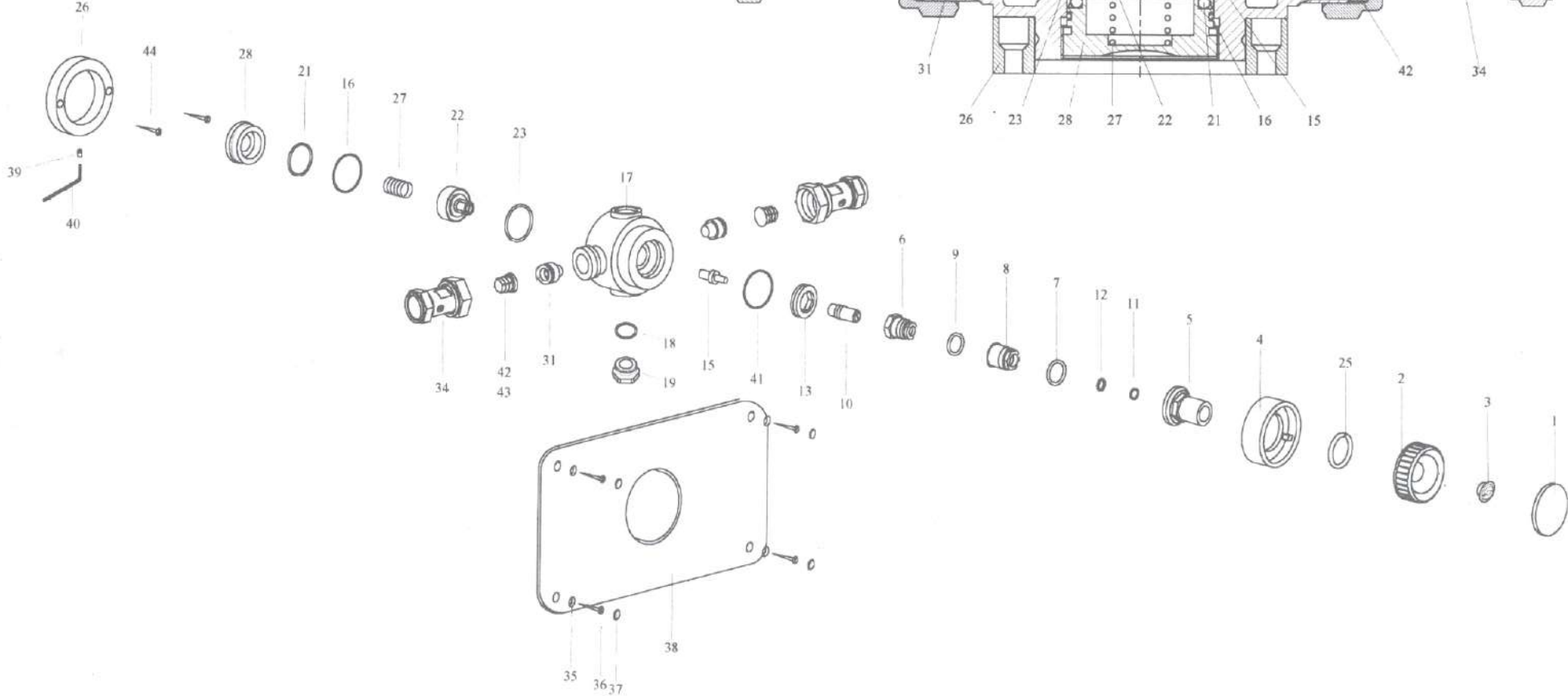

FIG 2