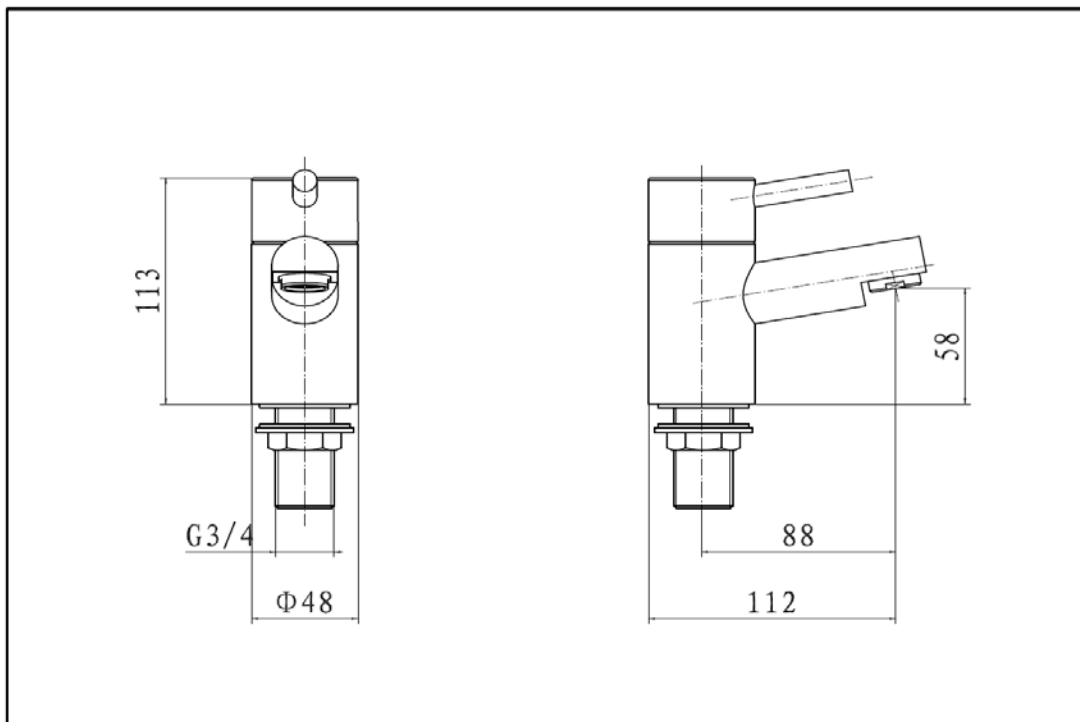

TAP016PL- PLAN BATH PILLAR TAPS**ILLUSTRATION: PLAN BATH PILLAR TAPS****BAR CODE: 5060168228543****COLOUR: CHROME PLATE****WEIGHT:****NET 1.6 kg****GROSS 1.7 kg****STANDARDS: BS EN 200****NOTES:****3/4" BSP CONNECTIONS
CERAMIC DISC TECHNOLOGY****Flow Rate: M.P**

0.2bar	0.5bar	1bar	2bar	3bar
5.5L/min	8.4L/min	12.7L/min	16.8L/min	20.8L/min

**BOX SIZE 220 x 150 x 90 mm**