

Handle & plate
design may vary
depending on
model chosen

SEQUENTIAL SHOWER VALVE

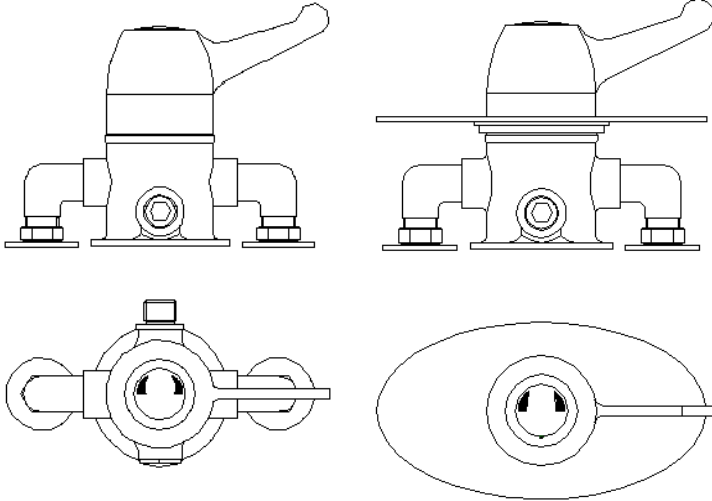

INSTRUCTION MANUAL

PLEASE LEAVE THIS MANUAL WITH THE END USER

CONTENTS

1. INTRODUCTION & SAFETY	1
2. DIMENSIONS	2
3. TECHNICAL DATA	3
4. OPERATION	4
5. COMPONENTS	5
6. SITE INSTALLATION	6-9
7. AFTERCARE	10
8. CALIBRATION	11-13
9. CARTRIDGE REPLACEMENT	14-15
10. FAULT DIAGNOSIS	16
11. INSTALLATION;	17
a) Conditions of use	17
b) Commissioning	18-19
c) Maintenance	19-21

1. INTRODUCTION

This installation guide is for the Thermostatic Sequential Shower Valve. It covers the installation, maintenance and operation of the Shower valve. This valve comes either as an Exposed Type Valve or a Concealed Type Valve. There are different handle and plate types for the valves depending on which valve was supplied.

The Thermostatic Shower Valve is a sequential valve, for showering and is thermostatically regulated by a wax element. It is designed to provide a flow of water at a safe temperature when installed as described in this manual. The shower valve is suitable for both low and high pressure installations. The valve is suitable, without modification, for all types of installation, including pumped gravity systems, mains pressure and combination boilers.

SAFETY

We recommend that this product is fitted by a fully qualified installer. The installation must comply with all current water regulations.

Please note: This valve MUST be commissioned on site to suit site conditions.

In order for this product to operate as designed it must be installed, commissioned and maintained as stated in this manual.

2. DIMENSIONS

ALL DIMENSIONS ARE APPROXIMATE

Exposed:

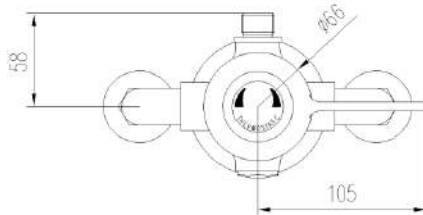
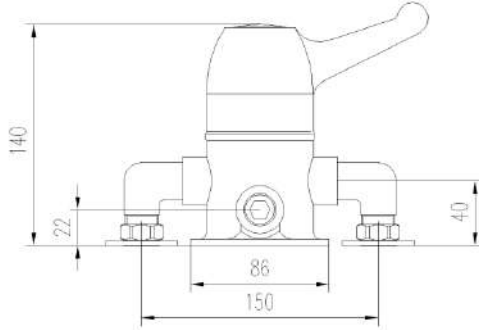

Concealed:

ALL DIMENSIONS ARE APPROXIMATE

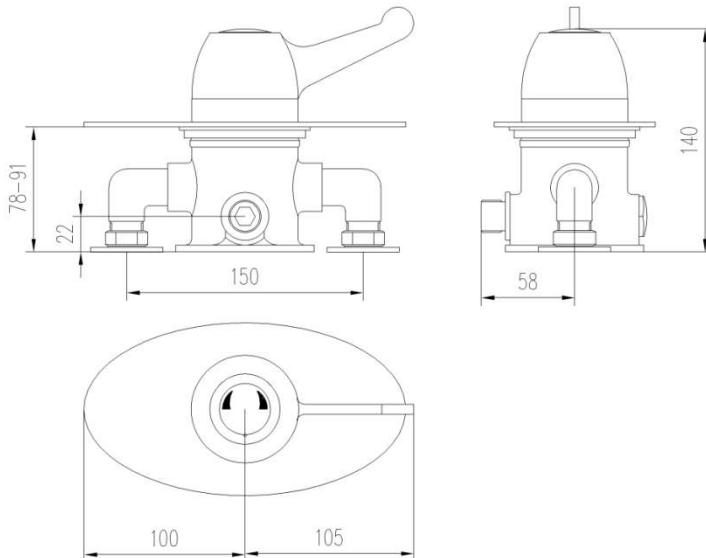

3. TECHNICAL DATA

Max Dynamic Pressure: 5 bar

Min Dynamic Pressure: 0.2 bar

Factory Outlet Temperature Setting: 43°C

Minimum Temperature Differential (Mixed water to hot water): 10°C

Temperature Stability: $\pm 2^{\circ}\text{C}$

The valve is suitable, without modification, for all types of installation, including pumped gravity systems, mains pressure and combination boilers.

4. OPERATION

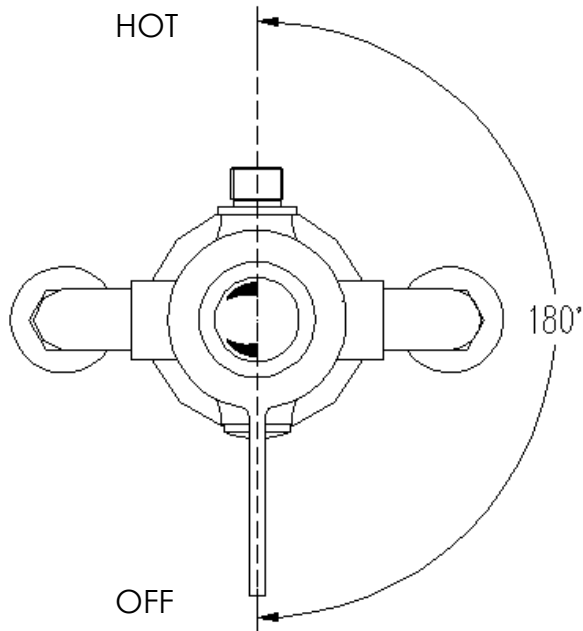

NOTE: THIS DIAGRAM DEPICTS A LEVER TYPE HANDLE BUT THE OPERATING PRINCIPLE IS THE SAME REGARDLESS OF THE HANDLE. THE ABOVE IS THE RECOMMENDED LEVER ORIENTATION.

The turning angle of the handle is 180 degrees, as illustrated above. This is from the fully closed position to the fully hot position. The cold water will get hot gradually from the off position through the 180° turn.

5. COMPONENTS

Exposed:

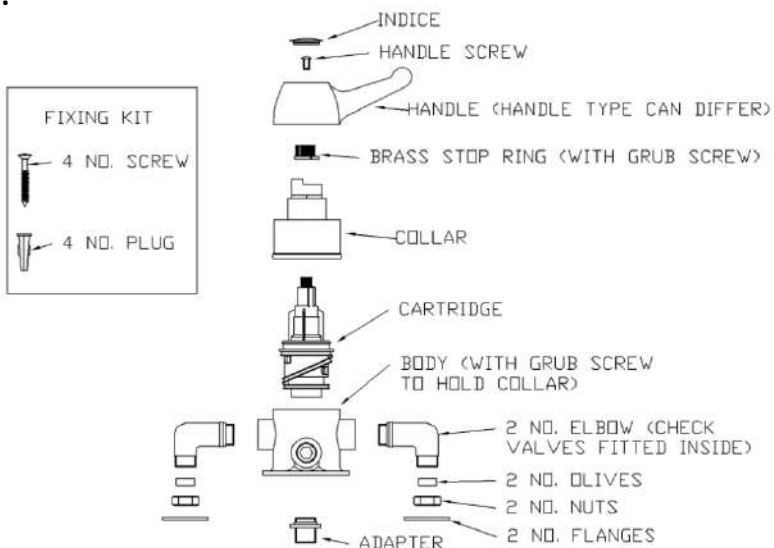

Concealed:

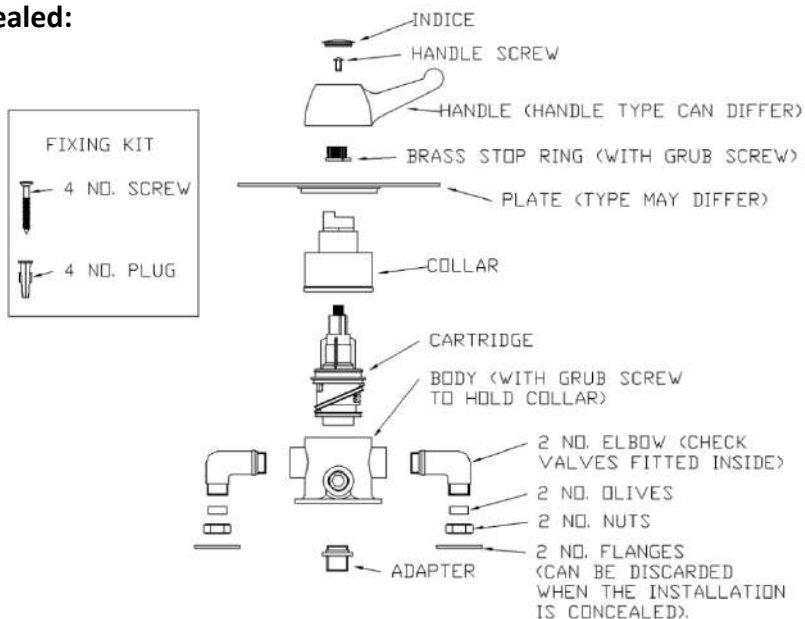

6. SITE INSTALLATION

- We recommend that this product is fitted by a fully qualified installer. **Please note: This valve MUST be commissioned on site to suit site conditions** and the installation must comply with all current water regulations.
- Please ensure that all components are in the box prior to fitting.
- There are Check Valves and Filters in the Elbows of this product.
- Please ensure that the site conditions are suitable for the installation of this product. The ideal site conditions can be found in section 11.
- It is recommended that Isolating valves are fitted in conjunction with this product. These are not supplied.
- Please refer to the diagrams in this section prior to installation.

- **Please plumb the valve in with the hot and cold going to the correct sides as detailed in the diagrams below. If you have plumbed it in the incorrectly already, the cartridge can be reversed (see cartridge replacement section).**

Exposed Installation:

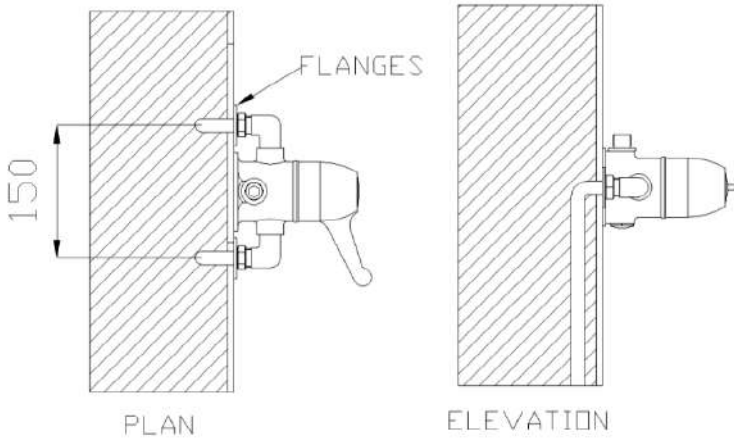

1. Make sure the pipes are at the correct centres as shown above.
2. Secure the valve to the wall using the screws provided. Be careful not to damage the screws or the valve in the process.
3. **Flush the pipework before connecting the valve. Debris can prevent the valve working correctly.**
4. Connect the pipework using the compression fittings provided. **Check for leaks.**
5. The water outlet side can be changed if required.
6. Calibrate and commission the valve as advised.

Note: Please make sure the inlet pipework is plumbed entering the valve on the correct sides. If the pipes are plumbed the wrong way around the cartridge can be taken out, turned 180° and replaced. This prevents the need for the pipework to be changed.

Concealed Installation:

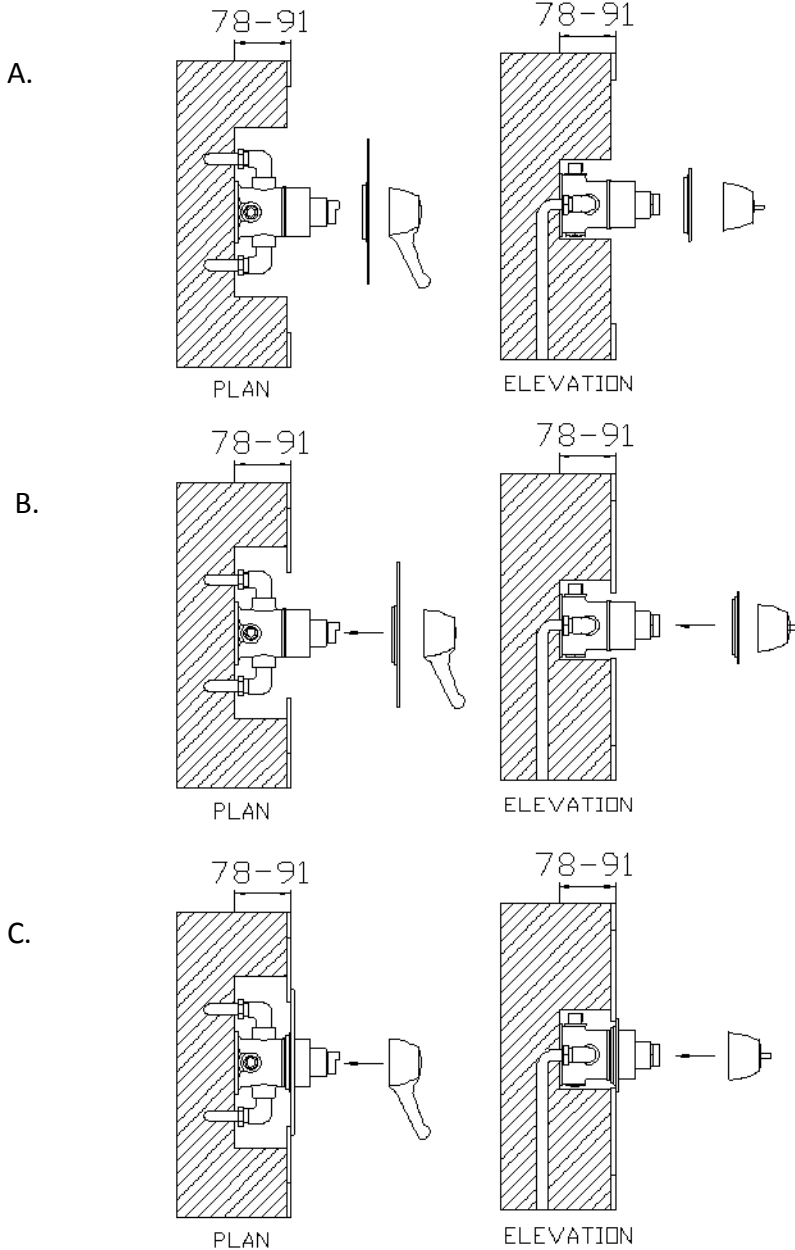

1. Make sure the pipes are at the correct centres. A cavity is required within the depth shown on the diagram. The depth depends on how far you want the valve protruding from the finished surface. The dimension is from the finished surfaced.
2. Remove the handle from the valve and place all components in a safe place (see section 8 for handle removal). You will need to fix the valve to a fixing surface within the cavity and fasten the valve with screws. Flush the pipes through before connecting the valve.
3. Connect the valve using the compression fittings. Connect the required outlet. **Check for leaks.**
4. Tile up to the valve so that the Plate will cover the cavity. **Do not permanently fill the cavity in as this may be required for access at a later date.**
5. Place the plate over the valve collar and push flush to the wall. Seal around the plate to prevent water entering the cavity. Replace the handle.
6. Calibrate the valve and commission as advised (see section 8 and 11).

7. AFTERCARE

- When cleaning the valve please do not use a substance that could possibly damage the surface finish. We recommend that soapy water with a mild detergent is used.
- Please take care not to damage the surface finish of the valve. The finish is polished chrome and can be easily marked.

8. CALIBRATION

PLEASE NOTE THAT ALL VALVES MUST BE CALIBRATED ON SITE BEFORE THEY ARE USED BY THE END USER. VALVES HAVE BEEN FACTORY SET UNDER LABORATORY CONDITIONS WHICH MAY NOT BE REPLICATED ON SITE.

Step 1:



Turn the handle clockwise until it stops in the off position. Remove the cap and undo the screw. Remove the screw and washer. Put these in a safe place. The handle can now be removed.

Step 2:

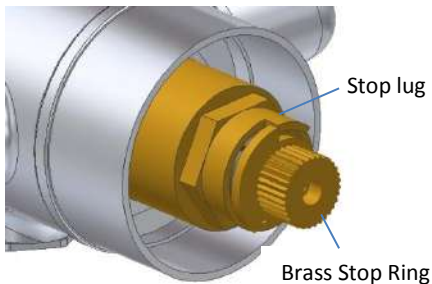

When the handle is removed the Brass Stop Ring will be revealed. This should be tight against the Stop Lug in the Off position. There should be no flow of water.

If there is a flow of water please go to Step 3.

Step 3:

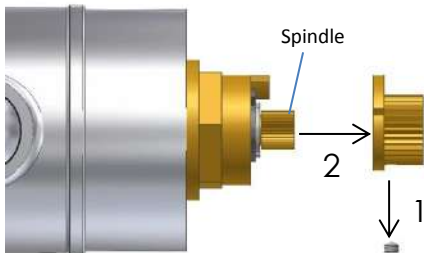

In order to stop the flow of water the Brass stop Ring position must be reset. To do this, remove the M4 grub screw holding the Brass Stop Ring in position. Then remove the Brass stop Ring.

Step 4:

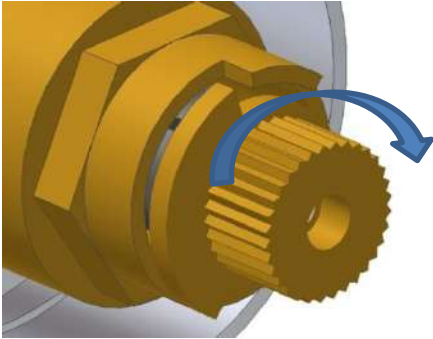

Place the Brass Stop Ring back on the spindle one serration anticlockwise of the Stop Ring. Turn the Brass Stop Ring clockwise until it reaches the Stop Lug. If the water still has not shut off repeat the step until it does.

When the water stops the Off position has been set and the grub screw can be replaced.

Step 5:

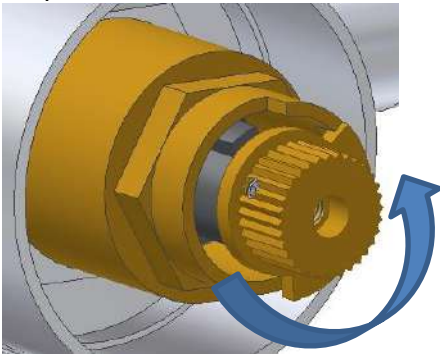

The water should now have stopped coming from the outlet. This means the Off position has been set and the max hot temperature can be set.

Turn the Brass Stop Ring fully anticlockwise until it reached the other side of the Stop Lug. This is the fully on position and the water from the outlet should be at a maximum of 43 °C. If it is please go to step 9. If not, proceed to step 6.

Step 6:

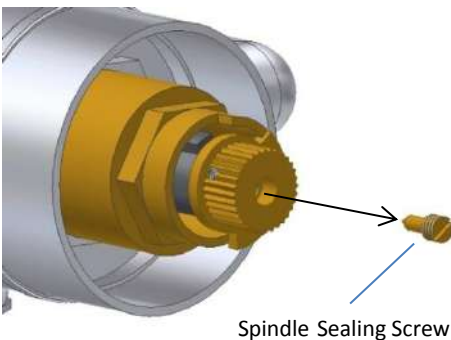

If the water is not the correct temperature, please use a small screw driver to remove the spindle sealing screw. This is located inside the spindle hole.

Please note: A small amount of water may come from inside the spindle hole when the spindle sealing screw is removed. This is normal.

Step 7:

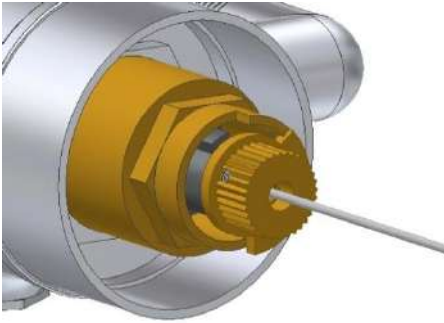

In order to calibrate the valve to the correct outlet temperature please place a 3mm flat bladed screw driver into the spindle. Locate the calibration screw slot inside and turn anticlockwise to increase the temperature or clockwise to reduce it. Allow the valve to stabilise after every adjustment and measure the outlet temperature.

Step 8:

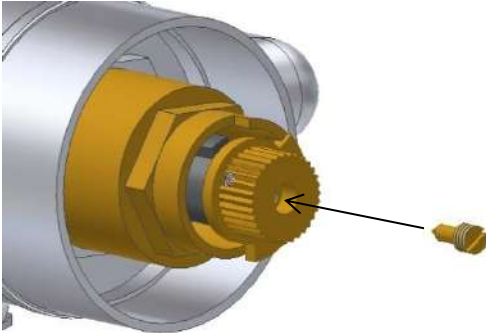

Once the stabilised outlet temperature is correct replace the spindle sealing screw.

Make sure the spindle screw is fully screwed in place and no water is coming from the spindle hole.

Step 9:



The handle can now be replaced and secured using the screw and washer. The indices can then be replaced. **Check for leaks.**

If a lever handle is being used please ensure that the lever is in the correct position.

The valve is now calibrated and is ready for commissioning and handover. Remember to leave this instruction and installation booklet with the end user.

9. CARTRIDGE REPLACEMENT

Step 1:



NB - Please make sure the valve is isolated from the water supply before replacing a cartridge. When the valve has been isolated, turn on the valve to let any water in the pipework escape.

Remove the handle cap and undo the screw. Remove the screw and washer. Put these in a safe place

Step 2:

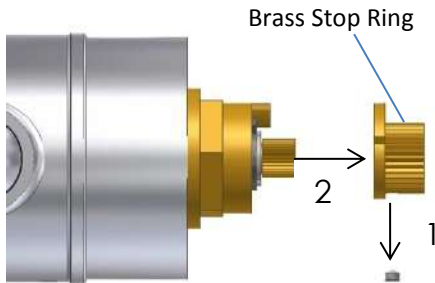

Brass Stop Ring

Please remove the M4 grub screw from the Brass Stop Ring. The Brass stop Ring can then be removed.

Keep the grub screw and the Stop Ring as they will be required to calibrate the new cartridge.

Step 3:

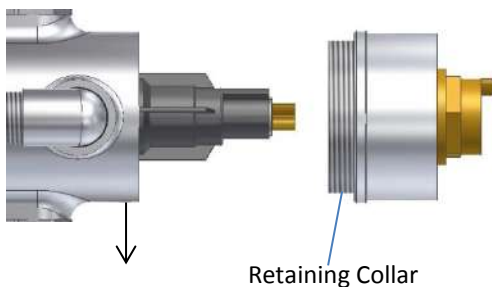

Retaining Collar

In order to remove the Chrome Retaining Collar you must remove the M5 grub screw that holds it. This is positioned at the underside of the body.

The retaining collar can then be taken off by placing a spanner on the flats and turning anti-clockwise.

Step 4:

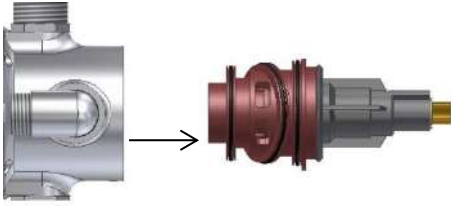

Pull the cartridge from the valve body.

There will be some residual water in the pipework that will pour out when the cartridge is removed.

Step 5:

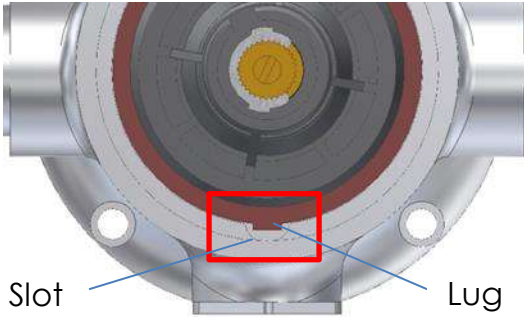

Place the new cartridge in the valve as in the diagram.

Note: It is very important to replace the cartridge correctly. The lug must be positioned in the correct slot. The hot and cold markings on the cartridge must align with the hot and cold inlets.

Slot

Lug

If the Valve Body has been plumbed the wrong way around the cartridge can be turned 180° to match.

Step 6:

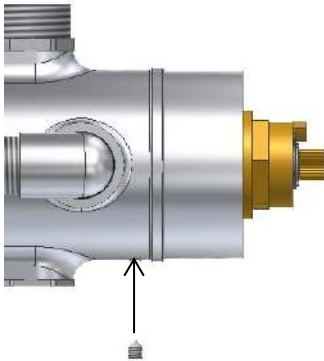

Tighten the chrome retaining collar by turning it clockwise. Tighten the collar to 17 Nm and then replace the grub screw to ensure the collar does not come loose.

Please ensure that the Cartridge Lug (mentioned above) does not come out of the slot when tightening down the Retaining Collar.

Reinstate the water supply to the valve and **check for leaks.**

AT THIS STAGE, THE VALVE NEEDS TO BE CALIBRATED. PLEASE GO TO THE CALIBRATION INSTRUCTION IN SECTION 8.

10. FAULT DIAGNOSIS

Fault	Possible Cause
No hot water from the Valve	<ol style="list-style-type: none"> 1. Check the hot water supply temperature from the boiler. 2. Inlets are reversed; cartridge needs to be turned 180°. 3. Calibration is incorrect. See section 8. 4. Operating conditions are incorrect. See section 11. 5. Blockage in system.
No cold water from the Valve	<ol style="list-style-type: none"> 1. Inlets are reversed; cartridge needs to be turned 180°. 2. Operating Conditions are incorrect. See section 11. 3. Blockage in the system.
No or low flow from the Valve	<ol style="list-style-type: none"> 1. Possible blockage in the system. 2. Operating Conditions are incorrect. See section 11. 3. Automatic Shut Off has been activated due to water supply conditions (See section 11). Either hot/cold water supply has failed.
Mixed water is too hot	<ol style="list-style-type: none"> 1. Calibration is incorrect. See section 8 in order to change to a desired temperature. Refer to section 11 for the maximum water temperature.
Flow from Valve in the off position	<ol style="list-style-type: none"> 1. The shut off position is incorrect. See section 8. 2. Debris blocking shut off. 3. Hot seat is damaged. 4. Cold shut off O ring is damaged.
Leak from Spindle	<ol style="list-style-type: none"> 1. The Spindle Sealing Screw is not screwed in far enough or not screwed in at all. See section 8.
Leak from Body	<ol style="list-style-type: none"> 1. Retaining Collar is not tightened properly. 2. Cartridge O rings need to be replaced.
Mixed Temperature fluctuating	<ol style="list-style-type: none"> 1. Hot supply temperature fluctuating (see section 11). 2. Supply pressure is fluctuating (see section 11). 3. Thermostat arrangement is faulty.

11. CONDITIONS OF USE

Key: High Pressure (HP)
Low Pressure (LP)

Table 1: Normal Conditions of use.

Supply Conditions	High Pressure	Low Pressure
Maximum Static Pressure (bar)	10	10
Flow Pressure Hot & Cold (bar)	1-5	0.2 - 1
Hot Supply Temperature (°C)	52 -65	52 - 65
Cold Supply Temperature(°C)	5 - 20	5 - 20
Minimum Temperature Differential (°C)	10	10

Table 2: Recommended Mixed Water Temperature

Application	Recommended Max Hot Water Temperature °C
Shower	41

b) COMMISSIONING

Method for Commissioning Thermostatic Mixing Valves

Purpose

Since the installed supply conditions are likely to be different from those applied in the laboratory tests it is appropriate, at commissioning, to carry out some simple checks and tests on each mixing valve to provide a performance reference point for future in-service tests.

Procedure

Check that:

- a) The designation of the thermostatic mixing valve matches the intended application.
- b) The supply pressures are within the range of operating pressures for the designation of the valve.
- c) The supply temperatures are within the range permitted for the valve and by guidance information on the prevention of legionella etc. Adjust the temperature of the mixed water in accordance with the manufacturer's instructions and the requirement of the application and then carry out the following sequence:

- a) Record the temperature of the hot and cold water supplies.
- b) Record the temperature of the mixed water at the largest draw-off flow rate.
- c) Record the temperature of the mixed water at a smaller draw off flow rate, which shall be measured.
- d) Isolate the cold water supply to the mixing valve and monitor the mixed water temperature.
- e) Record the maximum temperature achieved as a result of (d) and the final stabilised temperature.

NOTE: The final stabilised mixed water temperature should not exceed the values in Table 3.

- f) Record the equipment, thermometer etc. used for the measurements.

Table 3: Maximum Mixed water temperature °C

Application	Maximum Hot Temperature °C
Shower	43

c) MAINTENANCE

In Service Testing

Purpose

The purpose of in-service tests is to regularly monitor and record the performance of the thermostatic mixing valve. Deterioration in performance can indicate the need for service work on the valve and/or the water supplies.

Procedure

Using the same measuring equipment or equipment to the same specification as used in the commissioning of the valve, adjust the temperature of the mixed water in accordance with the manufacturer's instructions and the requirement of the application. Carry out the following sequence:

- a) Record the temperature of the hot and cold water supplies.
- b) Record the temperature of the mixed water at the largest draw-off flow rate.
- c) Record the temperature of the mixed water at a smaller draw-off flow rate, which shall be measured if the mixed water temperature has changed significantly from the previous test results (e.g.> 1 K), record the change and before re-adjusting the mixed water temperature check:
 - a) That any in-line or integral strainers are clean.
 - b) Any in-line or integral check valves or other anti-back siphonage devices are in good working order.
 - c) Any isolating valves are fully open

With an acceptable mixed water temperature, complete the following procedure:

- a) Record the temperature of the hot and cold water supplies.
- b) Record the temperature of the mixed water at the largest draw-off flow rate.
- c) Record the temperature of the mixed water at a smaller draw-off flow rate, which shall be measured.
- d) Isolate the cold water supply to the mixing valve and monitor the mixed water temperature.
- e) Record the maximum temperature achieved as a result of (d) and the final stabilised temperature.
- f) Record the equipment, thermometer etc. used for the measurements.

If at step (e) the final mixed water temperature is greater than the values in Table 3 and / or the maximum temperature exceeds the corresponding value from the previous results by more than about 2 K, the need for service work is indicated.

Frequency of in-service tests

General

In the absence of any other instruction or guidance on the means of determining the appropriate frequency of in-service testing, the following procedure may be used:

- a) 6 to 8 weeks after commissioning carry out the tests detailed in “In-Service Tests”.
- b) 12 to 15 weeks after commissioning carry out the tests detailed in “In-Service Tests”.

Depending on the results of the above tests, several possibilities exist:

- a) If no significant changes (e.g. ≤ 1 K) in mixed water temperatures are recorded between commissioning and 6 to 8 week testing, or between commissioning and 12-15 week testing the next in-service test can be deferred to 24 to 28 weeks after commissioning.
- b) If small changes (e.g. 1 to 2 K) in mixed water temperatures are recorded in only one of these periods, necessitating adjustment of the mixed water temperature, then the next in-service test can be deferred to 24 to 28 weeks after commissioning.
- c) If small changes (e.g. 1 to 2 K) in mixed water temperatures are recorded in both of these periods, necessitating adjustment of the mixed water temperature, then the next in-service test should be carried out at 18 to 21 weeks after commissioning.
- d) If significant changes (e.g. > 2 K) in mixed water temperatures are recorded in either of these periods, necessitating service work, then the next in-service test should be carried out at 18 to 21 weeks after commissioning.

The general principle to be observed after the first 2 or 3 in-service tests is that the intervals of future tests should be set to those which previous tests have shown can be achieved with no more than a small change in mixed water temperature.

