

GUILD

Burlington®

Square Thermostatic Single Outlet Concealed Shower Valve with Rail, Hose, Handset and Outlet Elbow

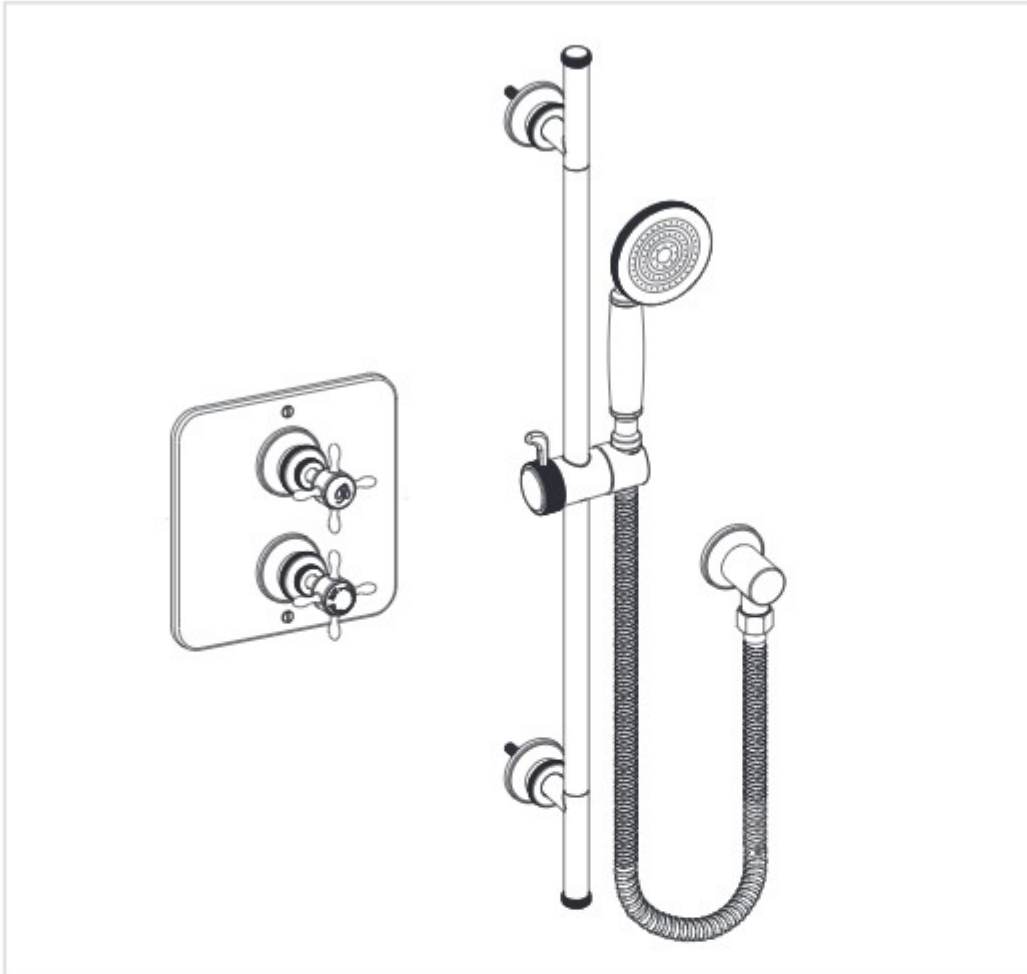

PRODUCT CODES:

GUSHOWERPACKSQ1



IMPORTANT INFORMATION BEFORE YOU START

Please read carefully and keep this information for further reference.

All products manufactured and supplied by Burlington are safe provided they are installed, used correctly and receive regular maintenance in accordance with these instructions. If you are in any doubt about your ability to install this product safely you must employ the services of an experienced qualified plumber.

The thermostatic valve has been designed to be compliant with the relevant UK standards applicable to this type of product governed by Type 2 TMV and WRAS. The valve is tested against BS EN 1111.

Operating pressure range: The valve will operate under low pressure but it is recommended that the minimum operating pressure is 0.5 bar. This thermostatic valve is suitable for use with all water systems up to a maximum operating pressure of 5.0 bar (beyond which we recommend pressure reducing valves to be fitted.)

The valve is provided with one outlet (on the top), which is controlled by a flow control cartridge. Commonly used for a

main shower head or a flexible shower kit.

Note: An independent, flexible hot and cold water supply pipe is recommended for use to ease maintenance. If installing a shower pump always install the pump before the shower valve.

The list below shows the recommended limits for correct operation:

	High Pressure
Maximum Static Pressure - Bar	10
Flow Pressure, Hot & Cold - Bar	0.5 to 5
Hot Supply Temperature - °C	55 to 65
Cold Supply Temperature - °C	Equal to or less than 25°

The British Burns Association recommends 37 to 37.5°C as a comfortable bathing temperature for children. In premises covered by the Care Standards Act 2000, the maximum mixed water outlet temperature of 43°C.

DIMENSIONS

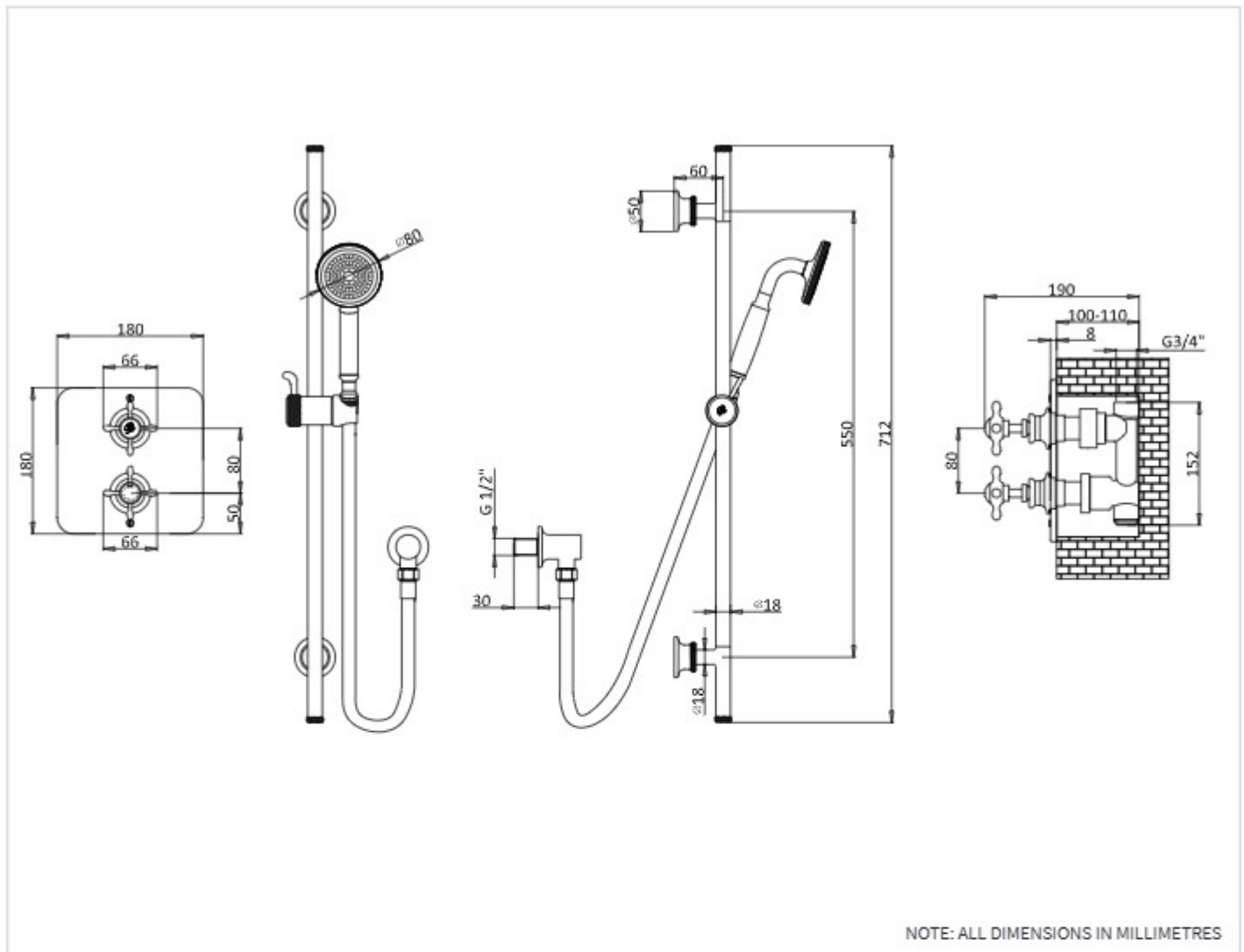

IMPORTANT INFORMATION

Please read carefully and keep this information for further reference.

These taps and mixers should be installed in compliance with the Water Regulations.

Where the supplies are unbalanced, i.e. Hot water from cylinder tank / cold from the mains, approved check valves must be fitted in the supply pipes.

For further details contact your Local Water Authority.

BEFORE YOU START

Important Pre-Installation Notes

Remove all packaging and check the fitting for damage before starting installation.

Warning: Before starting any installation please consider the following: before drilling into walls, check that there are no hidden electrical wires, cables or water supply pipes. This can be checked with the aid of an electronic detector.

If power tools are used do not forget to: -

Wear eye protection

Unplug equipment after use

Important:

Remember to turn off the mains water supply before connecting to any existing pipe work. Fitting isolating valves to the inlet feeds is recommended for ease of maintenance.

Warning: Before installing the new fitting it is essential that you thoroughly flush through the pipework in order to remove any remaining swarf, solder, etc. Failure to carry out this procedure could cause problems or damage to the workings of the fitting.

Take care when handling the 'flexible connecting pipes', do not bend, twist or crush them. Only tighten the pipes by hand. Do not crush or kink the shower hose, this could damage the hose and cause leaks.

COMPONENTS

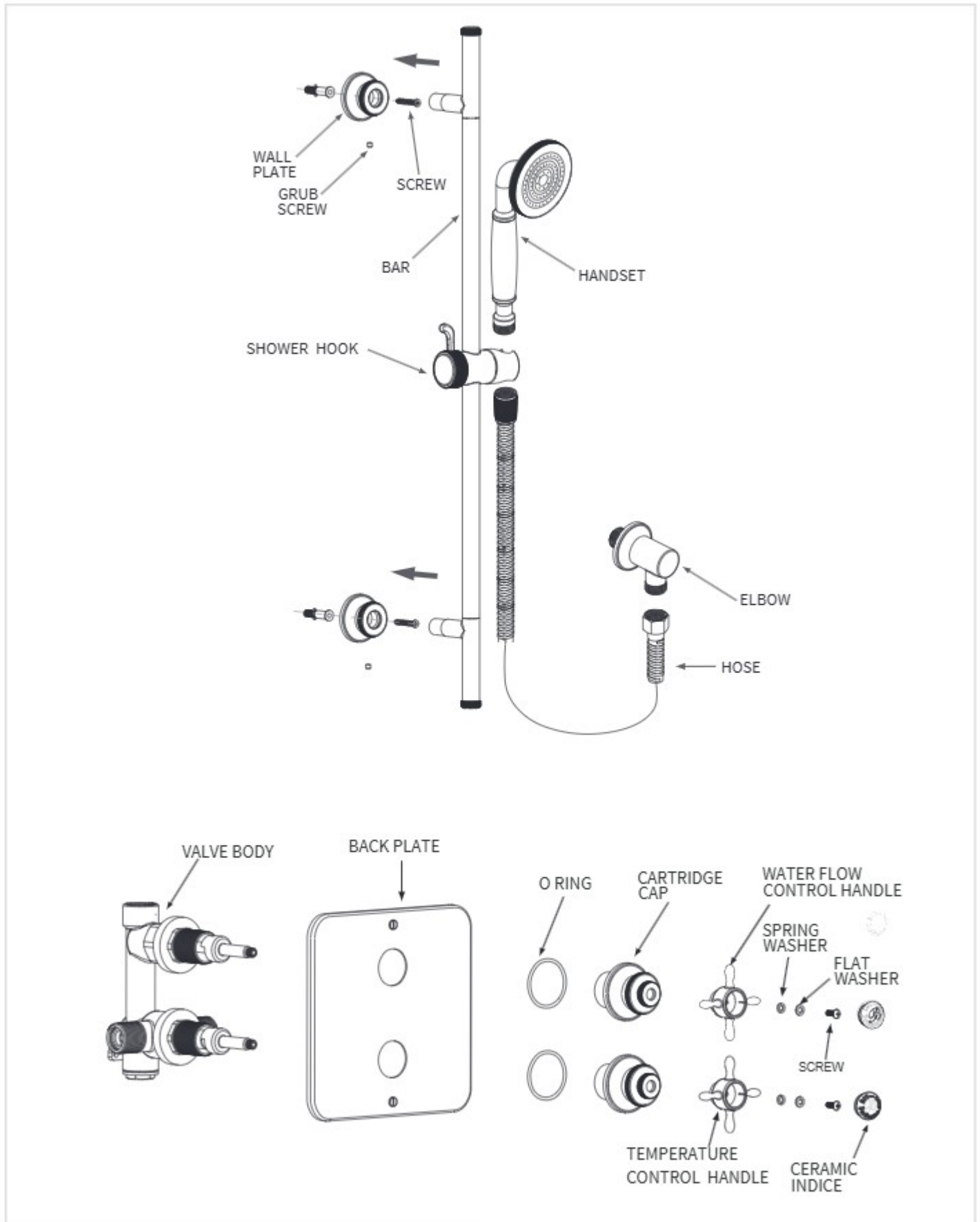

INSTALLATION

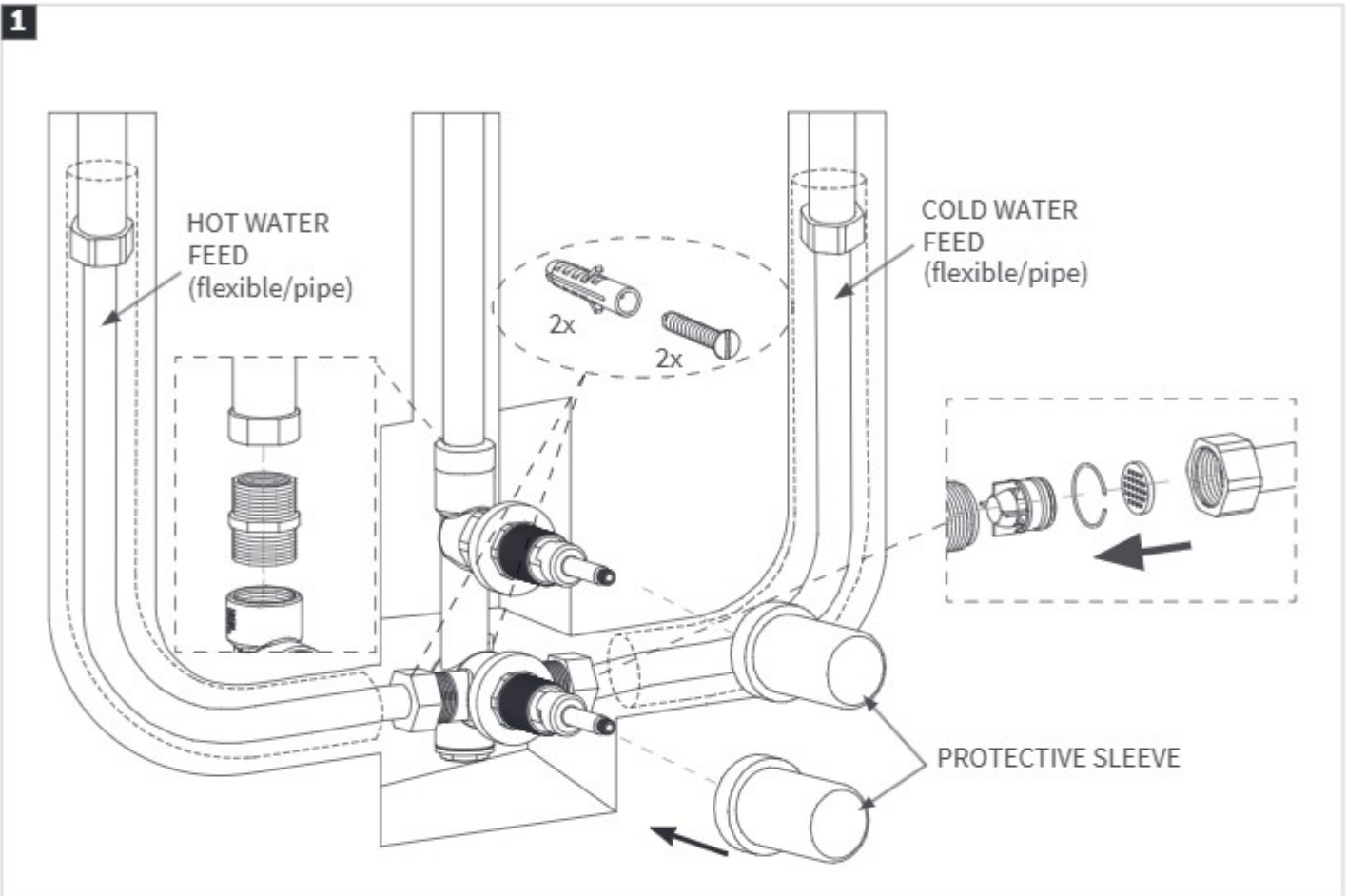

The valve should be installed in accordance with the water bye-laws. For further details refer to the latest copy of Water Bye-laws guide or your local water authority.

Note: Please check for any hidden pipes and cables before drilling holes in the wall.

The fitting of isolation valves is required as close as is practicable to both hot and cold water supply inlets. Put the valve (make sure the two protective sleeves are protecting the chrome section) onto the wall and mark the position of the fixing lugs (X2). Make sure the valve is set back from the front face of the wall by the appropriate depth to allow for plasterboard, tiling and filling etc. (min. 100 to max. 110mm) . Mount the valve to the wall using suitable fixings. Inlets and outlets are all tapped 3/4". Make all the pipe work connections using a thread sealer. Don't use the tapered adaptors.

Outlet at the top of valve is recommended for shower only, the pipe connection is recommended as the diagram above That will be convenient for taking off the valve for easy maintenance. Turn on supplies and test all connections for water tightness. (If necessary, the filter and check valve need to be cleaned) Then install the plasterboard and tile the wall.

INSTALLATION

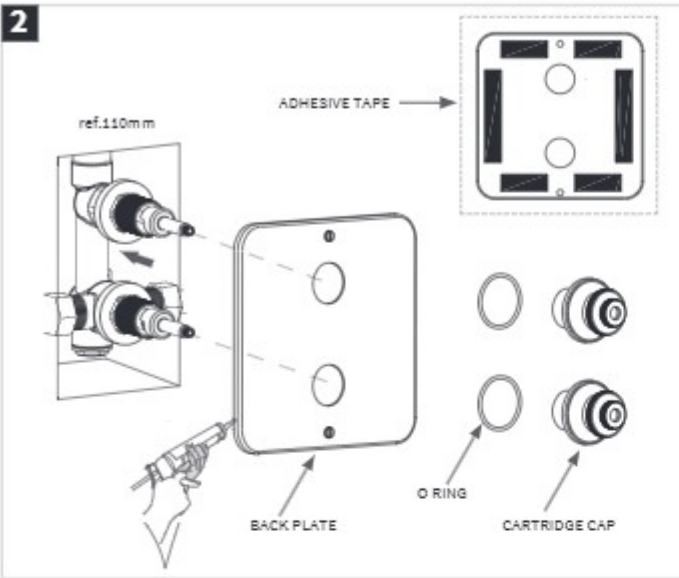

Mount the O-rings and cartridge caps onto the back plate. Make sure the O-rings are stuck in the groove at the bottom of the cartridge caps. Remove the adhesive tape film on the backside of back plate. Tighten cartridge caps onto the cartridge, and paste the back plate on the wall. Apply a narrow bead of silicone sealant around the back edge of the back plate and carefully press into position.

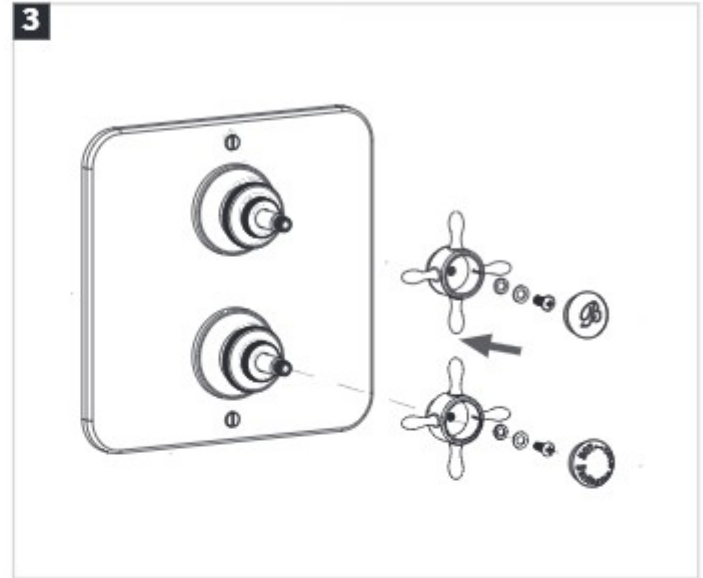

Mount the cross handles into position.

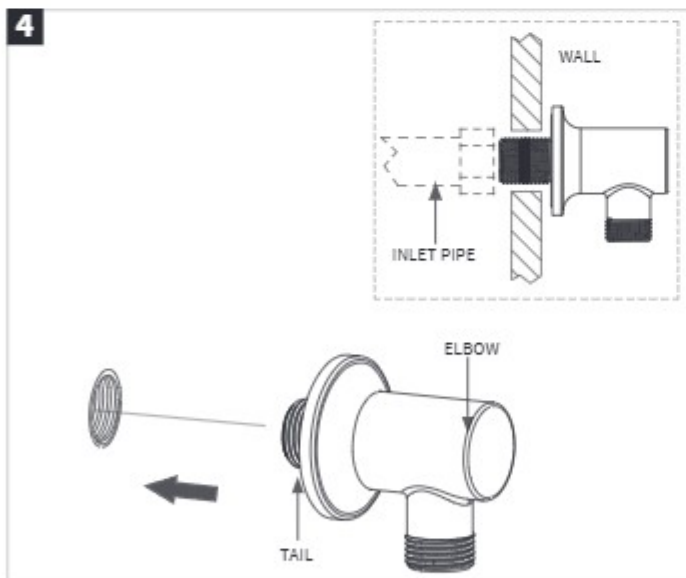

Connect the elbow with the outlet.

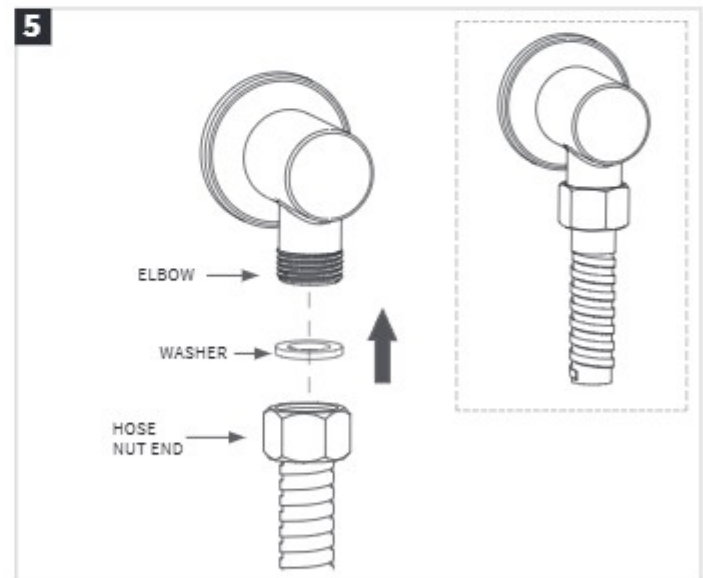

Connect the hose nut end and washer with the elbow .

INSTALLATION



Connect the hose cone end and washer with the shower handset.

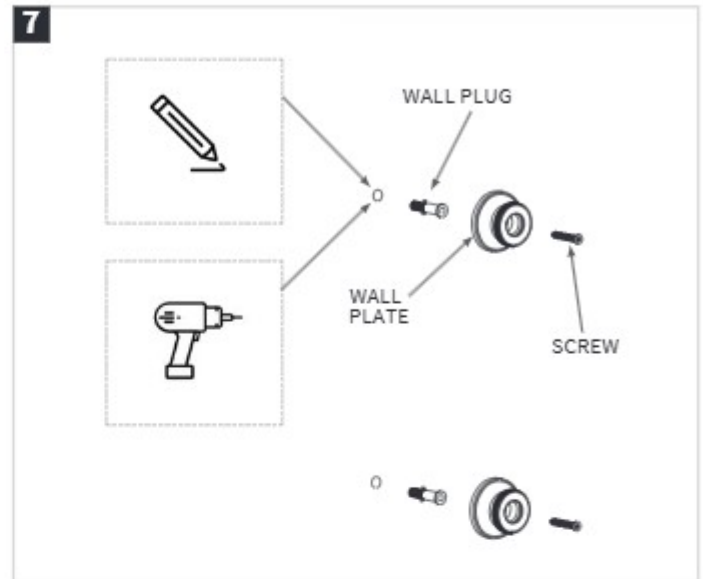

Make sure all is right, mark out the two fixing hole positions on wall. Drill holes. Insert wall plugs. Fix the wall plates onto the wall by screws.

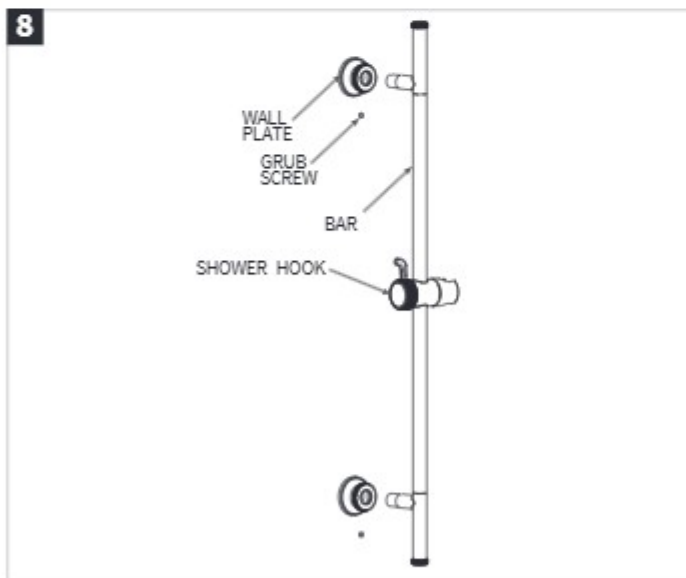

Make sure the shower hook at a suitable position. Insert and fix the bar to the wall plates with grub screws.

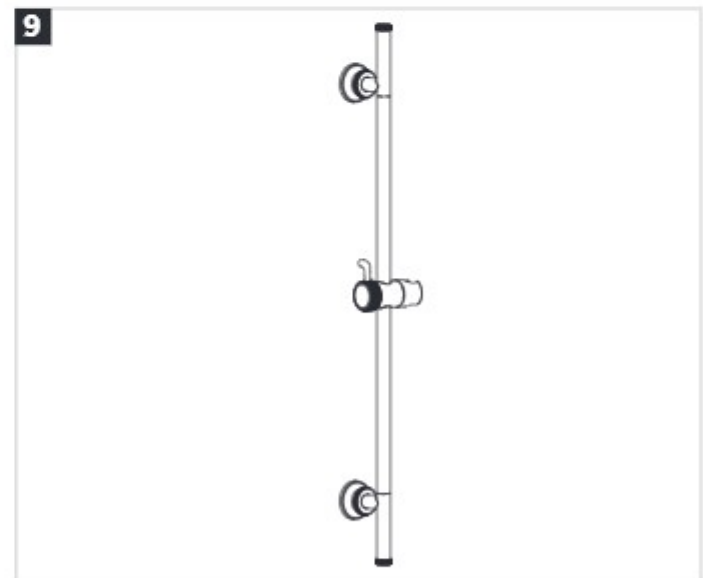

Complete.

OPERATION

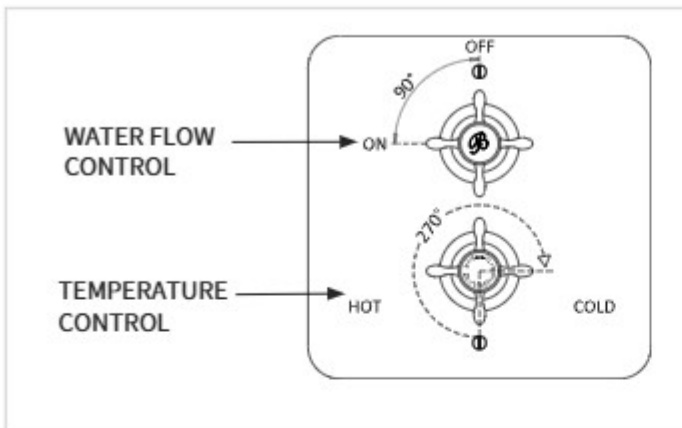

1. Turn the water flow control handle to increase/decrease the water flow and turn on/off.
2. Turn the temperature control handle to increase/decrease the water temperature.

TEMPERATURE SETTING

The temperature control handles on this product are factory set and should require no adjustment. However, if for any reason the handles and/or the cartridge is removed it is important the following procedure is followed.

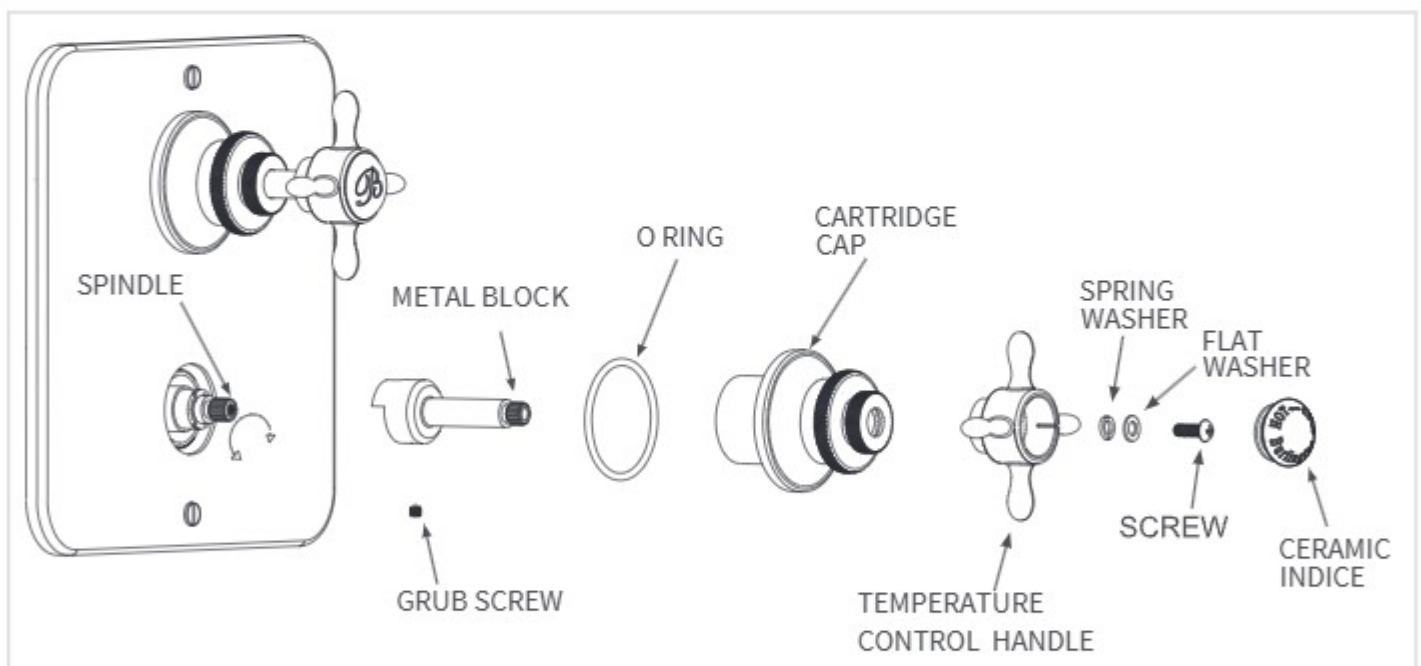

Pick off the ceramic indice and loosen the screw.

Pull off the temperature control handle, and unscrew the cartridge cap. Unscrew the grub screw and remove the metal block.

Rotate the exposed thermostatic spindle (clockwise for cold, and anti-clockwise for hot) until the maximum desired showering temperature is set. The suggested maximum pre-set temperature is 42°C.

Without any movement at the spindle, replace the metal block so that limit stop up to the right hand side of the limit stop on the cartridge.

Then refit the parts in turn.

COMMISSIONING & ANNUAL TEST

The installation of thermostatic mixing valves must comply with the requirement of the Water Supply (Water Fittings) Regulations 1999. Type 2 valve must be tested once a year, to check if it is out of the original maximum temperature set.

1. Prepare a calibrated thermometer.
2. Adjust to maximum water temperature.
3. Allow water running 5 seconds for stability, measure the mixed water temperature at the outlet.
 - The mixed water temperature at the outlet should never exceed 42°C for showers.
 - The mixed water temperature at the outlet should never exceed 46°C for bath filler.

Note: 46°C is the maximum mixed water temperature from the bath tap. The maximum temperature takes account of the allowable temperature. Tolerances inherent in thermostatic mixing valves and temperature losses in metal baths. It is not a safe bathing temperature for adults or children.

The British Burns Association recommends 37 to 37.5°C as a comfortable bathing temperature for children. In premises covered by the Care Standards Act 2000, the maximum mixed water outlet temperature is 43°C.

IF NOT, then the adjustment of the temperature is necessary following the “Temperature Setting”

1. Close the isolating valve at the Cold water supply. While the flowing is residual, and the water temperature has no any change obviously from the initial maximum temperature set.
2. Reopen the cold supply, retest the water temperature if there is no obvious no change. Then the valve is working correctly, no further service work is required.

TROUBLESHOOTING

1. Output water temperature does not correspond with temperature set
 - Cause: Thermostat has not been adjusted base on the existing home water system.
 - Remedy: Adjust the thermostat, refer to “Temperature Setting” procedure.
 - Cause: Hot Water temperature too low.
 - Remedy: Adjuster the water heater, increase hot water temperature to 65°.
2. Crossflow, cold water being forced into hot water pipe, or vice versa, when valve is closed
 - Cause: check valves dirty or leaking
 - Remedy: Clean the check valves or exchange if necessary
3. Very low flow or no flow
 - Cause: Supply pressure inadequate
 - Remedy: Check hot and cold feeds. If a pump has been installed, please check to see if the pump is working (the valve will shut down if either the cold or hot water supply fails).
4. Water will not run hot enough when first installed
 - Cause: Wrong maximum temperature setting
 - Remedy: Adjust the maximum temperature, refer to “Temperature Setting” procedure.

CARE & MAINTENANCE

Note: Before performing any maintenance on the valve, please ensure you isolate the water.

Note: After a long time usage of thermostatic valve, there will be some waste debris from the water pipe on and around the thermostatic cartridge or check valve, which will affect the flow and sensitivity of automatic temperature adjustment. Please take out the thermostatic cartridge, and clean the cartridge strainer. To avoid damage, please remove all chrome parts before any maintenance takes place.

CLEANING THE THERMOSTATIC CARTRIDGE

Remove the cartridge retaining ring. Pull out the thermostatic cartridge. Wash the thermostatic cartridge with clean running water, dry and lightly grease the seals (only use silicone grease). Put back the thermostatic cartridge (The locating lug should be sit inside the socket of housing), then tighten the retaining ring.

CLEANING THE PRODUCT

The material we use in our taps is very durable, nevertheless care should be taken when cleaning them. They should be cleaned only with warm soapy water followed by rinsing with clean water and drying with a soft cloth. All finishes are vulnerable to acid attack and some strong substances such as household cleaners, disinfectants, denture cleaners, hair dyes, wine making, and photographic chemicals can cause the surface to go black or peel.

Note: Never use abrasive detergents or disinfectants or those containing alcohol, hydrochloric acid or phosphoric acid.

CLEANING THE FILTER & CHECK VALVE

Cut off the Hot & Cold supply at the isolating valve. Disconnect the hot & cold water supply from the valve Use a suitable screwdriver to remove the fixing screws. Fetch out the valve, and take out the filter, check valve.

Clean the filter and check valve with clean running water, dry and lightly grease the seals (only use silicone grease). Put back all of the parts in sequence.

